

State Water Survey Division
WATER QUALITY SECTION
AT
PEORIA, ILLINOIS



SWS Contract Report 349

**THE PROCEDURES, OBSERVATIONS, AND RESULTS
OF A MIXING ZONE STUDY FOR COMBINED SEWER OVERFLOWS
AT PEORIA, ILLINOIS**

by

*Thomas A. Butts, Ralph L. Evans,
Dana B. Shackleford, and Donald H. Schnepfer*

Prepared for the City of Peoria

October 1984



CONTENTS

Introduction	1
General Information	2
Regulatory Implications	4
Scope and Purpose of Study	7
Acknowledgments	8
Sampling Design and Data Evaluation Procedures	9
Background Information	9
Physical Considerations	14
Overflow Simulation Equipment	26
Pumping Unit	26
Piping and Fittings	27
In-Line Appurtenances	34
Couplings	34
Flowmeter	35
Suction Lines	36
Dye Injection	37
Sampling Equipment	38
Laboratory Equipment	43
Operating Procedures	45
Prerun Preparation	45
Overflow Simulation	50
Sampling	51
Laboratory Procedures	58
Data Analysis Procedures	60
Conceptual Approach	60
Rational Approach	65
Results	68
Discussion	87
Speculative Mixing Zone	93
Summary and Conclusions	98
References	100
Appendices	
Appendix A. Photographs of Combined Sewer Overflow Sites	103
Appendix B. Equipment and Materials Specifications	111
Appendix C. Sampling Collection Form	117
A Note Concerning Appendix D	119

LIST OF FIGURES

Figure 1.	Peoria CSO locations.....	3
Figure 2.	Pump installation at Cedar Street.....	28
Figure 3.	Pump installation at Cedar Street, showing suction line.....	28
Figure 4.	Pump and piping set-up.....	30
Figure 5.	Sewer manhole injection point and river outfall.....	30
Figure 6.	In-line flowmeter.....	32
Figure 7.	Dye tank and metering pump.....	32
Figure 8.	Schematic of boat equipped with dye sampling set-up.....	40
Figure 9.	Sampling boat 4, showing stakes in background.....	44
Figure 10.	Sampling bottles in carrying case.....	44
Figure 11.	Time versus dye concentration at station 61+00 with dye injection at Cedar.....	47
Figure 12 a-b.	Plan view of sampling locations.....	52
Figure 13.	Schematic of sampling marker location set-up.....	53
Figure 14.	Setting markers using tag line from shore.....	54
Figure 15.	Study area, showing boats in sampling positions.....	57
Figure 16.	Illinois River cross sections below Cedar Street.....	62
Figure 17.	Bottom profiles below Cedar Street.....	63
Figure 18.	August 3, 1983 surface percentage contours, partially submerged, 3200 gpm.....	77
Figure 19.	August 9, 1983 surface percentage contours, partially submerged, 1600 gpm.....	78
Figure 20.	August 16, 1983 surface percentage contours, overbank, 1600 gpm.....	79
Figure 21.	August 23, 1983 surface percentage contours, overbank, 3200 gpm.....	80
Figure 22.	August 31, 1983 surface percentage contours, overbank, 2400 gpm.....	81
Figure 23.	September 13, 1983 surface percentage contours, partially submerged, 2400 gpm.....	82
Figure 24.	Maximum dye percentage composition in river at Cedar Street outfall (station 30+25) 25 feet from outfall.....	85
Figure 25 a-b.	Sewer discharge projection into river at station 30+25 to 1 percent of the sewer composition (partially submerged and overland).....	88
Figure 26 a-c.	Lateral penetration of stated residual sewer flow into the Illinois River.....	90
Figure 27.	Elements for estimating a mixing zone.....	96

LIST OF TABLES

Table 1.	Sewer Locations and Characteristics.....	14
Table 2.	Examples of Typical Vertically Extrapolated Dye Concentrations.....	66
Table 3.	Dates and Conditions Relative to Successful Overflow Simulations.....	68
Table 4.	Dye Concentrations 8/03/83, 0 ft.....	69
Table 5.	Dye Concentrations 8/03/83, 3 ft.....	70
Table 6.	Dye Concentrations 8/03/83, 10 ft.....	71
Table 7.	River Dye Concentrations as a Percentage of Sewer Concentrations 50 Feet from Shore.....	73
Table 8.	Distance from Shore the Maximum Dye Concentration Was Observed.....	75
Table 9.	P ₂₅ Estimates for 1982 Cedar Street Combined Sewer Overflow Sampling Data.....	86
Table 10.	Parabolic Model Coefficients and Distances to Selected Percentage Points at Station 30+25.....	91
Table 11.	Longitudinal Distances to Specified Contour Line Percentages.....	93
Table 12.	Physical Characteristics of a Mixing Zone at Peoria	96

THE PROCEDURES, OBSERVATIONS, AND RESULTS
OF A MIXING ZONE STUDY FOR COMBINED
SEWER OVERFLOWS AT PEORIA, ILLINOIS

by

Thomas A. Butts, Ralph L. Evans,
Dana B. Shackelford, and Donald H. Schnepfer

INTRODUCTION

Almost all major communities located along the Illinois River are partially served by combined sewers which overflow directly to the waterway during wet weather. These overflows are comprised of surface runoff and sewage, which can cause water quality problems in the receiving stream. The pollution potential of these discharges had never been directly investigated until 1982. During the summer of 1982, at the request of the City of Peoria, the State Water Survey (SWS) conducted a comprehensive study of the effects of combined sewer overflows (CSOs) on the river water quality. The study was partially funded by the Illinois Environmental Protection Agency (IEPA) and was coordinated by the Greater Peoria Sanitary District. It was designed to determine if Peoria CSOs were violating IEPA water quality standards under various runoff and river flow conditions.

The IEPA suggested that the river water quality sampling results would be more meaningful if mixing zones in the areas of the outfalls could be delineated. This entailed designing and conducting a study entirely independent of the water quality sampling phase. The river water quality sampling results have been evaluated and reported upon in

a report by the staff of the State Water Survey's Water Quality Section (1983). The results of a study conducted during the summer of 1983 to delineate mixing zones are reported here.

General Information

Peoria is served by both combined and separate sewers. The combined system consists of approximately 123 miles of conduit draining 2950 acres, including the older areas of the city known as the "east" and "west" bluffs and that area lying below the bluffs and bordered by the river. During storms, the combined sewers overflow directly into the river at 20 locations along approximately four miles of riverfront. The amount of overflow is controlled by 23 regulators. Generally, the regulators are adjusted to divert flows, in excess of dry weather flow, directly into the river. The dry weather discharge is passed into a riverfront interceptor for conveyance to the wastewater treatment facilities of the Greater Peoria Sanitary District (GPSD).

The locations of the 20 overflows are shown in figure 1. The overflow sites and conduits are vestiges of the old combined sewer system which discharged directly into the river before the interceptor was built and treatment provided. Most of the outfall conduits are old and lack uniformity in design and structural integrity. Some are relatively small sewer pipes, while others are so large a person can easily walk upright in them. Examination of figure 1 shows that the river's configuration varies considerably throughout the outfall area. Some of the overflows discharge into a wide, lake-like environment while

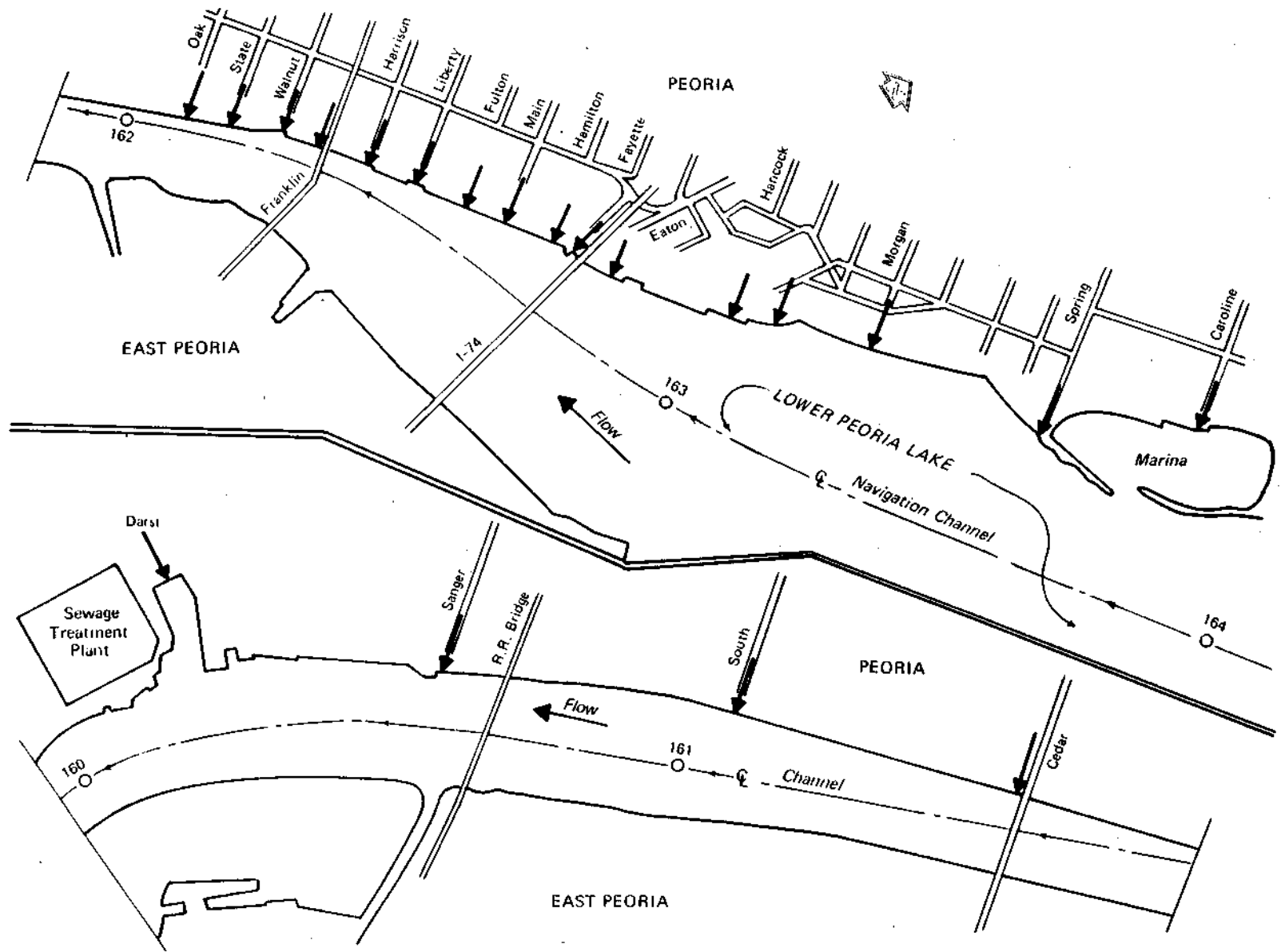

Figure 1. Peoria CSO locations

others discharge into a relatively constricted channel; one discharges in a protected marina and another into a shallow backwater bay. These factors all combine to form a complex and difficult study situation relative to generating typical mixing zone information.

Regulatory Implications

Until the early 1970s, wet-weather, combined sewage diversion to Illinois streams was an acceptable practice. The rationale for this acceptance was that, since CSOs occurred during wet weather, stream flows were high, thereby providing sufficient dilution to minimize water quality degradation. With the passage of the Illinois Environmental Protection Act of 1970 and the Federal Water Pollution Control Act of 1972, the practice became unacceptable. These Acts led to the development of stream water quality standards. Implementation of these stream standards was largely contingent upon the successful enforcement of effluent standards and limitations imposed upon specific discharges via a permit issuance program titled the National Pollutant Discharge Elimination System (NPDES). Conflict between the two sets of standards occurred when a water quality standard was more restrictive than the corresponding effluent standard stipulated in the discharger's NPDES permit.

The Illinois Pollution Control Board attempted to reconcile this conflict by allowing mixing between the effluent discharge and stream flow within a confined area. Specifically, Section 302.102 of the Board's Rules and Regulations relative to water pollution outlines the requirements for a mixing zone, to wit:

- a. In the application of this Chapter, whenever a water quality standard is more restrictive than its corresponding effluent standard then an opportunity shall be allowed for the mixture of an effluent with its receiving waters. Water quality standards must be met at every point outside of the mixing zone. The size of the mixing zone cannot be uniformly prescribed. The governing principle is that the proportion of any body of water or segment thereof within mixing zones must be quite small if the water quality standards are to have meaning. This principle shall be applied on a case-by-case basis to ensure that neither any individual source nor the aggregate of sources shall cause excessive zones to exceed the standards. The water quality standards must be met in the bulk of the body of water, and no body of water may be used totally as a mixing zone for a single outfall or combination of outfalls. Moreover, except as otherwise provided in this Chapter, no single mixing zone shall exceed the area of a circle with a radius of 183 m (600 feet). Single sources of effluents which have more than one outfall shall be limited to a total mixing area no larger than that allowable if a single outfall were used.

- b. In determining the size of the mixing zone for any discharge, the following must be considered:
 1. The character of the body of water,
 2. The present and anticipated future use of the body of water,
 3. The present and anticipated future water quality,
 4. The effect of the discharge on the present and anticipated future water quality,
 5. The dilution ratio, and
 6. The nature of the contaminant.

- c. In addition to the above the mixing zone shall be so designed as to assure a reasonable zone of passage for aquatic life in which the water quality standards are met. The mixing zone shall not intersect any area of any such waters in such a manner that the maintenance of aquatic life in the body of water as a whole would be adversely affected, nor shall any mixing zone contain more than 25 percent of the cross-sectional area or

volume of flow of a stream except for those streams where the dilution ratio is less than 3:1.

These mixing zone rules and regulations were somewhat arbitrarily devised. They were developed on rational ideas and concepts rather than on sound scientific principles and data. During the formative stage of the design of the CSO river sampling plan, IEPA officials emphasized the importance of sampling within the mixing zone as well as outside it. To meet this requirement the Water Survey proposed a single mixing zone which would encompass all the outfalls but still meet the criteria outlined in paragraphs a, b, and c above. The proposed zone would have been about 19,000 feet long and would have extended an average of 60 feet from shore, basically equalling the area of a circle 600 feet in radius. In the narrow river reach subjected to CSOs, the proposed mixing zone could have extended at least 100 feet from shore, and it would not have contained more than 25 percent of the cross-sectional area or flow.

This proposal was not accepted by IEPA officials; they insisted that direct mixing zone determinations be made. After an in-depth investigation of possible alternatives was conducted, a method of simulating overflows by pumping river water into the overflow pipe and injecting this water with fluorescent dye was selected. The mixing characteristics of the dye-injected discharge would then be traced under steady state conditions.

Ideally, the mixing zone determinations should have been made before the wet weather river sampling was started so that correctly positioned sampling within the mixing zone could be achieved. Preliminary

investigations revealed conclusively that an in situ mixing zone study could not be completed prior to the start of the wet weather river sampling nor could it be feasibly done concurrently with river sampling. An entirely independent study had to be undertaken at a later time. The CSO river water quality sampling was completed during the summer of 1982, whereas the mixing zone study was completed during the summer of 1983.

Scope and Purpose of Study

Initially, a comprehensive study was visualized. It was to be designed to provide information that could be extrapolated for use in defining mixing zones at CSO locations throughout the length of the Illinois River. In the end, however, practical problems, many of which were not apparent until field operations got under way, limited the scope of the study and the applicability of the data generated. Instead of examining at least one generalized sewer outfall type over a wide range of sewer and river flow conditions, the final study was limited to examining two types of outfalls occurring at one general site for intermediate river flows. Consequently, the original intent and purpose had to be modified. In the final analyses, the purposes were reduced to:

1. Producing in situ mixing zone information of sufficient scope and magnitude to provide regulatory agencies with some idea of factors governing the configuration of a mixing zone.
2. Formulating and developing a methodology by which future mixing zone studies could be patterned.

3. Generating information which could possibly be used by hydraulic engineers to verify hitherto unsubstantiated theoretical mixing models.

Acknowledgments

This study was sponsored and partially funded jointly by the City of Peoria and the Illinois Environmental Protection Agency. The work was performed under the general supervision of the Chief of the Illinois State Water Survey. The entire staff of the Water Quality Section of the Water Survey participated in some phase of the study at various times. Specifically, thanks are extended to Shundar Lin, Wuncheng Wang, Raman K. Raman, and Thomas Hill for their assistance in field sampling. Special commendations are extended to Judson Williams, Thomas Walkowiak, Donald Roseboom, and Dave Beuscher for the extreme physical effort they put forth during pump placement and pipe set-ups. Also appreciated are the long hours Dave Hullinger, Paula Reed, and Linda Johnson spent in the laboratory analyzing samples.

John Brother, Jr., Linda Riggin, and William Motherway, Jr., prepared the illustrations; the original manuscript was edited by Gail Taylor. The assistance and advice extended by Richard Helm of Randolph and Associates is much appreciated. Special mention is due James Carlisle, Executive Director of the Greater Peoria Sanitary District, and Steve Van Winkle, Director of Public Works, City of Peoria, for the administrative assistance they provided to make the project successful. Also, thanks are extended to Archer Daniel Midland Company (ADM) for the use of riverfront property on which much of the study was conducted.

SAMPLING DESIGN AND DATA EVALUATION PROCEDURES

The study was developed around the concept of directly measuring the mixing characteristics of sewer discharges and river water by simulating full-scale overflows into the river. The area of influence of the overflow in the river was delineated by the fluorescent dye tracer Rhodamine WT.

Background Information

A comprehensive computer search of the literature was made to gather background information for developing a study design. Little pertinent information was found. Most of the published information was only slightly related to the type of study envisioned. Much of it concerned theoretical and/or idealized concepts. Probably the most complete reference on the subject of stream mixing is the publication by Fischer et al. (1979), related to all facets of the subject. Its most relevant portion is Chapter 5, "Mixing in Rivers," which makes pointed references about the general lack of field data needed to substantiate theoretical or laboratory-generated concepts. • As an example, in Section 5.1.2 the authors note:

We know of no experiments on vertical mixing in a depth-varying flow, but we see no reason why the customary practice should not be adequate. On the other hand, the rate of transverse mixing is strongly affected by the channel irregularities because they are capable of generating a wide variety of transverse motions....However, there have not been enough experiments in flumes, let alone in natural channels, to define how the mixing coefficients vary with the size of the irregularity, the best one can say is that the bigger the irregularity, probably the faster the transverse mixing.

A recent extensive literature review and report on stream mixing by

Lin (1983) indicates that little information has been generated in the last few years to fill the voids mentioned by Fischer and his co-authors. Lin, in his "Project Summary," concluded:

The capability to analytically solve the mixing phenomenon in rivers is very limited, as can be seen from the literature being reviewed. The present mathematical model [as developed by Lin] which includes velocity variations also has limitations such as the restrictions of constant channel width and depth. There is, therefore, a need to develop a model which takes variations of depth, width, and velocity in a river into consideration.

The only practical in situ study undertaken historically which was found to even remotely address objectives similar to those proposed for this project was performed by Hetling and O'Connell (1966). Rhodamine WT dye was used to characterize the mixing of the Washington, D. C., Blue Plains Sewage Treatment Plant effluent in the Potomac River estuary. Dye was injected continuously into the outfall sewer for 13 days, and the extent of its dispersion in the tidal waters was traced using a fluorometer dispatched aboard a moving boat. Obvious differences exist between this situation and that for periodic sewer overflows into a moving stream. It provided only limited information and help relative to designing this study.

Other mixing zone and diffusion studies reviewed in detail were those of Schiller and Sayre (1973), Maxwell and Chang (1971), Rutherford et al. (1980), Paily (1981), Sanders et al. (1977), and Neely (1982). Many additional articles and reports were superficially reviewed but will not be commented upon in this section. Some will be briefly cited in later sections to present specific information that appeared to be relevant to the study design and implementation and to data reduction

and analysis.

Many studies have been conducted to investigate the dispersion of cooling water effluents in surface waters ranging from fresh water lakes and streams to marine environments. Mixing and dispersion involve complex mathematical theories and concepts which have been verified almost exclusively using laboratory experiments. Fischer's extensive works and publications are generally abstract and theoretical, but with the limited in situ data available, he has, at times, attempted to "marry" some theoretical concepts and formulas to practical problems and solutions.

Neely (1982) has attempted to apply some of the theoretical information to practical mixing problems relevant to both conservative and nonconservative chemical and biological pollutants. His approach is succinct, relatively simple, and possibly practical.

Schiller and Sayre (1973) have provided a very comprehensive manual concerning buoyant thermal discharge dissipations. Extensive graphs and figures are presented which can be used to evaluate mixing zones using such known factors as temperature, stream and sewer flows, and outfall geometry and submergence. The most useful information extracted from this publication was that the outfall configuration and degree of submergence significantly influence mixing, at least relative to cooling water discharges. Consequently, outfall shapes, sizes, and degrees of submergence were given full consideration in the early formulation of the study design.

In reviewing the Maxwell and Chang (1971) publication on diffusion

patterns in flow systems, the reader quickly becomes aware of the complex analytical and mathematical procedures used to study mixing phenomena. Although the authors devise procedures for predicting mixing for discharge outlets and for predicting the diffusion of tracers in streams, the methods appear to be impractical for ordinary use.

The work of Rutherford et al. (1980) provided some insight into the mixing and dispersion of a dye tracer in a large river. The researchers had hoped that the dye dispersion would conform to the Fickian theory of longitudinal dispersion; however, it did so only to a limited degree. A poor match-up of theoretical prediction to field observations resulted because the dye persistently hung up in dead zones along the shoreline. Aerial photography was used for estimating lateral dispersion coefficients.

The Paily (1981) article deals principally with the development of a comprehensive mathematical model for describing cooling water mixing in a river. Of significance, however, is Paily's review of mixing zone criteria established by regulatory agencies for the 15 states either bordered or bisected by the Mississippi and Missouri Rivers. The various state regulatory requirements appear to have been developed with four basic concepts in mind:

1. Stream hydrologic, hydraulic, and physiographic characteristics.
2. Future water use and water quality.
3. Dilution ratios relative to 7-day, 10-year low flows.
4. Allowances for permanent zones-of-passage for aquatic drift and wildlife.

Paily feels that the most important criterion to be used in establishing mixing zone boundaries is number 4; i.e., the zone-of-passage concept. He also states that mixing zone overlapping should be avoided or minimized to prevent adverse synergistic effects.

Sanders et al. (1977) performed a large-scale mixing study using a dye tracer in a small river having a relatively uniform cross section over much of its length. A three-dimensional time-varying model was used to effectively derive longitudinal, lateral, and vertical turbulent diffusion coefficients. A unique dye dispersal sampling system was devised to sample dye slugs as they passed two different sections of the stream. Slug injection was used in place of steady state, continuous injection because of economics and sampling design simplicity. Also, the uniform stream geometry made slug injection possible. However, the analytical solutions for determining the diffusion coefficients are much more involved and complex for slug injections, and precision and accuracy are less than for continuous injections. The authors state categorically, however, that continuous point source injection is the preferred method • principally because once steady-state conditions are established, dye concentrations become independent of time, thereby permitting continuous and/or multiple sample collecting. This smooths sampling error by increasing precision, and it simplifies the analytical procedures required for determining diffusion coefficients. These observations, together with the fact that the stream geometry in the area of the Peoria CSOs is highly irregular, dictated the use of a continuous injection design plan for this study.

Physical Considerations

Many physical factors had to be considered in the design and implementation of the mixing zone study. The riverfront overflow layout and the interrelationships between individual sewers and/or groups of sewers influenced the design approach. Figure 1 presents an overall plan view of the 20 discharge points, and table 1 gives hydrologic, hydraulic, and geometric information relative to each. Appendix A includes photographic views of each outfall or, in the case of totally submerged discharges, the outfall location.

Table 1. Sewer Locations and Characteristics

Sewer Name	Corps River Mile	Sewer Size*	Peak Flow Rates (cfs)**		Discharge Submergence Condition at Flat Pool		
			for Rains in in/hr of		Full	Partial	Free Overbank
			0.37	1.56			
Caroline	163.82	36	5	64	X		
Spring	163.62	60	21	270			X
Morgan	163.31	48x58	0	36			X
Green	162.94	30x45	4	48			X
Hancock	162.90	30	0	2			X
Eaton	162.72	60	8	.92		X	
Fayette	162.71	42	22	220		X	
Hamilton	162.68	42	0	8			X
Main	162.61	42	10	88		X	
Fulton	162.50	36	0	4	X		
Liberty	162.43	48	1	8	X		
Harrison	162.37	20	1	6			X
Franklin	162.28	60	0	3			X
Walnut	162.21	34x51	6	68			X
State	162.13	30	0	18	X		
Oak	162.05	48	8	100		X	
Cedar	161.51	72	44	458		X	
South	160.97	(2)48	6	84			X
Sanger	160.55	72	3	28		X	
Darst	160.12	84	36	430			X

* Single and double values represent circular and elliptical sections, respectively

** Based on preliminary estimates from Randolph and Assoc. facility planning document (1976)

A comprehensive, rational study design has to include sewer outfall types, sewer overflow rates, and river flows and/or stages. Four basic outfall conditions exist, as shown in table 1. Ideally one of each representative sewer type should be sampled over a wide range of sewer discharges and river flows. The most practical and economical approach would be to bracket the river flow by sampling during extremes in flow; extrapolation techniques could be utilized to approximate mixing zones for intermediate situations. During each river condition, sewer overflow rates would be simulated. Therefore, an all-encompassing sampling program would include a minimum of 16 runs: 4 sewer types, 2 river flows per sewer type, and 2 overflow simulations per sewer per river flow. The practicality of accomplishing such an ambitious endeavor was investigated.

First, consideration was given to developing a means of simulating or creating overflows. Several schemes were investigated including: (1) plugging and filling a large sewer section (the filling could be accomplished by pumping river water, diverting sewage, or using fire hydrant water) and then releasing the "plug" flow; (2) creating a continuous steady flow by diverting sewage, using fire hydrant water, or pumping river water into a manhole in the proximity of the river bank; and (3) using natural overflow events.

After thorough consideration, the concept of plugging the sewer was abandoned. Sufficient fire hydrant water was available at most sites, but city and fire officials were somewhat unreceptive to using this water unless absolutely necessary. For water quality, public health, and public relation considerations the idea of diverting sewage was

rejected. Filling by pumping would be possible; however, it would be expensive when coupled with the cost of purchasing the plugs. Plugs designed to seal sewer sections are commercially available, but they are expensive and difficult to use, especially under such controlled conditions as would be required for this study. Also, the data generated by using plug flows are difficult to analyze mathematically. Development of dispersion coefficients in conjunction with a predictive model is impossible using plug flow data unless idealized conditions exist in the receiving stream.

Using natural overflow events did not appear to be an attractive alternative for several reasons, the principal one being the lack of finite control. Almost everything would be left to chance. The probability of experiencing the desired matching sewer overflows and river discharge rates would be remote. The unsteady sewer flows would create problems in maintaining a constant dye concentration in the discharges, and the attendant wet weather would create difficult and unpleasant sampling conditions. Also, data analyses and modeling would probably prove to be even more difficult than for a plug flow scheme.

The only viable alternative appeared to be to pump river water into sewers to simulate overflows. However, a number of potential problems became apparent during the formulation of procedures to be used in this approach. Securing a pump of sufficient capacity to realistically simulate overflows proved to be very difficult. Various local, state, and federal agencies were contacted as to the availability of large-capacity, portable, self-powered pumps on a loan basis. Agencies

contacted were the Peoria Fire Department, the Greater Peoria Sanitary District, the Peoria Water Company, the Metropolitan Sanitary District of Greater Chicago, the Illinois State Emergency Services and Disaster Agency, and the U. S. Army Corps of Engineers. Almost all could provide pumps, but none were of sufficient capacity.

The largest available pump was an 8-inch unit having a maximum capacity of approximately 2000 gpm (4.5 cfs), a discharge rate well below the minimum desirable level needed to reasonably simulate overflow rates produced even during small rainfall events (see table 1). An exhaustive canvass of heavy equipment rental firms concerning leasing a pump also was unproductive; no large portable pumping units were available, and rental fees for even small units were prohibitive. New pumps of the minimum desired size were not readily available. One manufacturer was found that made an acceptable unit, which under low suction lifts and small head losses could pump up to 4000 gpm (9 cfs).

The discharge conduit for the pump had to be carefully selected also. It had to be lightweight and smooth, with low head loss characteristics, and had to be amendable or adaptable for use with some type of temporary, quick coupling device.

Access to either the river and/or sewer manholes to set up the pump and piping would be difficult. A thorough survey was made of all 20 overflow sites, and only a limited number of these appeared useable. Accessing the pump by land, water, or both was considered. A barge fleeting service company was contacted relative to water access, but the arrangements were found to be potentially cumbersome, time-consuming,

and expensive. Daily costs up to \$900 could have been incurred, including pump loading and unloading fees, flat-barge rental, and towing charges. In the end only land access was considered. A brief evaluation of each specific outfall site will be presented in the following paragraphs. During the discussions, reference should be made to the photographs contained in Appendix A.

Caroline - This outfall is totally submerged under about 3 feet of water inside the Detwiler Marina harbor about 25 feet north of the boat ramps. This represents an atypical situation which did not warrant study. It is, however, the only location at which the pump and piping could have been easily placed.

Spring - This sewer discharges into a deep ditch about 250 feet from the river. The pump could be easily moved to the top of the river bank, but the suction lift would have been excessive during normal pool stage. In addition, a run here would have produced questionable results since the creek-like discharge empties into a shallow section of the river more lake-like than riverine. Pump placement using water transportation would not have been possible here because of the shallow littoral area.

Morgan - Reference to the appropriate photographs in Appendix A clearly reveals the handicaps which would be encountered by locating a study site here. Foremost is the fact that the sewer opening has become about two-thirds plugged by riprap and debris. In addition, the steep, high bank, set back over 50 feet from the river, would preclude pumping from land and the shallow shore area would make a water set-up difficult. To compound the potential difficulties, the nearest manhole is over 400 feet from the river.

Green - All the problems inherent at Morgan, plus additional ones, exist at this site with the exception that the shore area is deeper and more riverine in nature. The outfall is almost totally silted shut, the bank is steep and wooded, the nearest manhole is over 400 feet from the river, and barge docking facilities exist immediately downstream - an intolerable interference.

Hancock - The outfall is located in the busiest area of a gravel unloading dock. The pipe opening is almost constantly blocked during unloading operations. The very nature of its location precludes its use as a study site.

Eaton - This outfall is located in a downstream extension of the gravel barge unloading facilities. However, unlike Hancock, this area is seldom used for docking or unloading; consequently, it held some promise as a study site. The pump could be easily placed at the top of the sheet metal piling. The suction lift of 18 feet could be managed, albeit with some difficulty, by coupling two available 13-foot hose lengths. However, a significant obstacle to the utilization of this site is the long distance to the nearest manhole and the type of area which has to be crossed to reach it. Over 400 feet of pipe would have to be laid, with much of it traversing an access road (heavily travelled by cement mixer trucks) and a railroad yard. As a consequence, this site was considered a last alternative for studying a partially submerged outfall discharge.

Fayette - Two sewers discharge side by side just below the 1-74 highway bridge. The one nearest the bridge is a combined sewer while

the one just downstream and backset somewhat is a storm sewer receiving runoff from the 1-74 roadway. A pump could be positioned on the headwall with some effort, but overall the site has very limited possibilities. The nearest manhole is far removed from the river, requiring the crossing of the cement truck access and railroad yard, and in addition, the manhole is located in the center of well-traveled Water Street. Another drawback is that the sewer overflows into a small bay area characterized by eddy currents.

Hamilton - This outfall is almost 80 percent silted shut. For that reason alone it is unsuitable for study. Also, pump access either by river or water would be extremely difficult and the nearest manhole is over 400 feet from the river at the intersection of Water and Hamilton Streets.

Main - In terms of accessibility and ease of setting up, this is an ideal site. The outfall is located at the edge of a parking lot and the nearest manhole is fewer than 300 feet from the water edge. However, river sampling would be impossible since the retired ferry, the City of Baton Rouge, is permanently moored immediately below the outfall for use as a dock for the excursion boat, the Julie Belle Swain.

Fulton - Some question exists about even the existence of this outfall; supposedly it is a submerged discharge located about 400 feet below the Main Street overflow just above the end of a sheet metal piling riverfront retaining wall. The nearest manhole is not definitely known. It is suspected of being in a line which angles toward the river from the Main Street overflow sewer manhole. Pump and pipe placement

would be relatively easy here; however, constant river traffic from the Julie Belle Swain and shore side barges could cause serious sampling and data interpretation problems.

Liberty - This sewer is submerged at an unknown location below a storm water sewer headwall. The manhole is about 360 feet up Liberty Street. Pump and pipe placement would be possible, but the riverside situation is similar to that at Fulton; heavy barge traffic passes within 20 feet of the shore, and often tows temporarily moor here while waiting for clearance to pass under the Franklin Street lift bridge.

Harrison - Land access to this sewer is blocked by a high chain-link fence surrounding private property. Pump and pipe placement is essentially impossible by either land or water. The discharge is located only a few hundred feet upstream of the Franklin Street bridge, and river traffic interference would be considerably worse than at Liberty. Structurally this is the smallest overflow pipe in the system.

Franklin - This overflow is located immediately downstream of the Franklin Street bridge, and any data generated by a study here would be greatly influenced by barges maneuvering to pass through the lift span of the bridge. The barge tows often reverse engines and side shift to make the passage, creating waves and churning motions in the water near the shore.

Walnut - Walnut is several hundred feet downstream of the bridge, and potential study results would be subjected to the same river traffic interferences as described for Franklin. In addition, an old railroad bridge pier has been left standing about 50 feet from shore directly in

line with the outfall. Even if simulated overflows would have been conducted here or at Franklin these sites would have eventually had to be abandoned since a demolition crew started dynamiting and destroying the old pier early in the summer.

State - Initially, this site appeared to be an attractive location for several reasons. State Street is paved up to the river, and the nearest manhole is only about 350 feet up the street. Also two types of sewers could be studied after pump placement, since a storm sewer (discharging overbank) and a submerged combined sewer exist side by side. Devising a method for placing the pump close to the river to effect suction lift appeared feasible. Some ingenuity in doing this, however, would have to be exercised because the bank is steep and rippapped. Also, a set of railroad tracks presents a slight obstacle to pipe placement, and barges at times dip close to shore in preparing for the Franklin Street Bridge passage. This latter fact would preclude water placement of the pump.

Oak - The situation at Oak appeared similar to that at nearby State; i.e., if a system could be devised to get the pump sufficiently close to the river to pull suction, then simulated runs could be made. This overflow represents a partially submerged condition. Therefore, coupled with the two conditions at State, three of the four sewer outfall types could be studied with a minimal movement of materials and equipment. The nearest manhole is located about 300 feet from the river in the center of the Post Office truck unloading area parking lot. Mail trucks would have to be rerouted, causing some inconvenience. Some sampling

interference from river traffic could result since the sewer is located at the spot where barges initiate maneuvering for passage at the Franklin Street Bridge. Both the State and Oak sites have an added advantage over all other locations in that the river channel is basically natural and straight, and the cross sections are relatively uniform for about 3000 feet below the State outfall. No other river reaches in the outfall area come close to displaying these desirable characteristics.

Cedar - This sewer offered distinct set-up possibilities. The advantages included the availability of two sewer types discharging side by side. A 24-inch storm sewer discharges overbank immediately upstream of the partially submerged combined sewer. Also, the manholes for both are only about 100 feet back from the river. The site is directly behind the Water Quality Section office building. A sheet metal piling head wall is available for pump placement at the water edge. Some disadvantages are: (1) the operation would have to take place on heavily guarded private property housing a large distilling and grain shipping industry, (2) constant movement of grain hauling trains would present hazardous working conditions, (3) the piping would have to be laid under a set of railroad tracks, (4) it would not be possible to sample a significant portion of the mixing zone because of grain loading at a docking area beginning 600 feet below Cedar, and (5) a highly irregular shoreline and variable cross sections would make data interpretation difficult.

South - The potential for studying this site is limited. The

principal advantage is that the nearest manhole is only about 150 feet from the river. However, pump placement by either land or water would be extremely difficult. The steeply inclined bank is over 50 feet from the water edge, while the water is only about 1 foot deep 100 feet from shore. A sandy shoal has developed directly out from the outfall and emerges as an exposed sand bar below. During normal pool stage, the entire area can be briefly dewatered by drawdown created by some barge and tow passings.

Sanger - This location offers some potential as a study site. Pump placement by water would be relatively easy, and placement by land would be difficult but possible. The nearest manhole is supposedly located 300 feet from the river in the middle of the street immediately north of the railroad tracks. However, it could not be located; apparently it has become buried due to a steady build-up of gravel in the roadway. A barge has been permanently grounded 50 feet below the outfall which would influence the mixing characteristics. This would produce results that probably would not be transferable to similar outfall types.

Darst - This site offers no potential for study. The sewer empties into a large shallow bay area over 700 feet from the river proper. The bottom is shallow, but the detention time in the bay is great, and the bottom sediments, consisting primarily of sludge, would absorb much of the dye before it reached the river. The nearest manhole is only 250 feet from the sewer headwall. The pump, however, could not be placed anywhere in the bay area without causing a recycling of dye-contaminated water.

The details of the reconnaissance of the combined sewer overflow system have been presented here because it serves at least three purposes. To begin with, it is the first systematic documentation of the condition and location of the conduits at the discharge points. The exact locations of a number of overflows were questionable (some still are). Authorities considered Main Street a storm sewer discharge, but interviews with the owner of the "City of Baton Rouge" and direct observations proved it was not. The exact locations of the submerged discharges at Caroline and State Streets were determined. A scuba diver was used to locate Caroline, and dye injection was used to locate State. State was found to be submerged in about four feet of water immediately below the State Street storm sewer headwall. It was previously thought to discharge somewhat above the headwall. Some question still exists as to the exact location of Liberty and as to whether Main has functionally replaced Fulton as the receiver for overflows from the Main-Fulton portion of the sewer system. Small but persistent dry weather discharges were observed at Green, Franklin, and South. Those at Franklin and South have been corrected.

Second, the documentation provides the information necessary for developing a study plan and sampling scheme. Third, the information clearly shows that, while general classes of sewer discharges exist, each outfall is essentially unique, and any mixing zone data developed at a given site must be applied with caution to any other location either within or outside the Peoria system.

State Street was selected as the first choice. The second and third

most attractive sites were sewers at Oak and Cedar located below the State site. One baseline could be established to include all three outfalls. A carefully surveyed line was measured beginning with State as 0 + 00 and extending 8000 feet to a point just below Sanger. Between State and South the baseline was easily established along the railroad tracks which parallel the river between these two points. At South the river and tracks diverge and the baseline had to be established overland.

Overflow Simulation Equipment

Pumping river water to a manhole in a sewer conduit to simulate an overflow was the method chosen for simulating overflows. Securing applicable equipment to accomplish this proved to be difficult, time-consuming, and expensive. In some instances, trial and error situations developed, resulting in unforeseen errors, delays, and expenses. In several instances Peoria Sanitary District, City of Peoria, and Peoria Water Company heavy equipment had to be retained to aid in the operation. Often questions directed to equipment manufacturers and suppliers relative to specific applications of materials and products could not be answered. Applications had to be made to situations for which some products were not specifically designed.

Pumping Unit

Acquiring a pump of sufficient size to produce even a reasonable

overflow proved to be difficult. Because no lendable or leasable pump could be found, one had to be purchased. Through a local vendor, a used 10-inch Jaeger Sykes pump capable of producing up to 8.25 cfs was secured. The cost was \$7500, or about a third of the cost of a comparable new unit. The pump and prime mover specifications are given in Appendix B; the unit, as set up at Cedar, is shown in figures 2 and 3.

Two minor modifications were made to the pumping unit before delivery—an oil pressure gage and a muffler were installed. The diesel engine, even after installation of the muffler, was extremely loud, and this necessitated wearing ear protection when in close proximity to the running diesel. The pump and engine operated satisfactorily except for the occurrence of two minor problems. Once the fuel line became air locked and had to be systematically bled; on another occasion, the radiator hoses developed intolerable leaks and had to be replaced.

Piping and Fittings

The selection of adequate piping proved to be as difficult as finding a pump. The conduit had to meet four requirements: (1) it had to be lightweight and readily moveable by hand, (2) it had to have a low friction factor to minimize head loss, i.e., capacity, (3) it had to be capable of being easily and quickly coupled or uncoupled, and (4) it had to be affordable.

Piping made of aluminum, asbestos-cement, and plastic appeared to be sufficiently lightweight for use. Aluminum irrigation pipe with

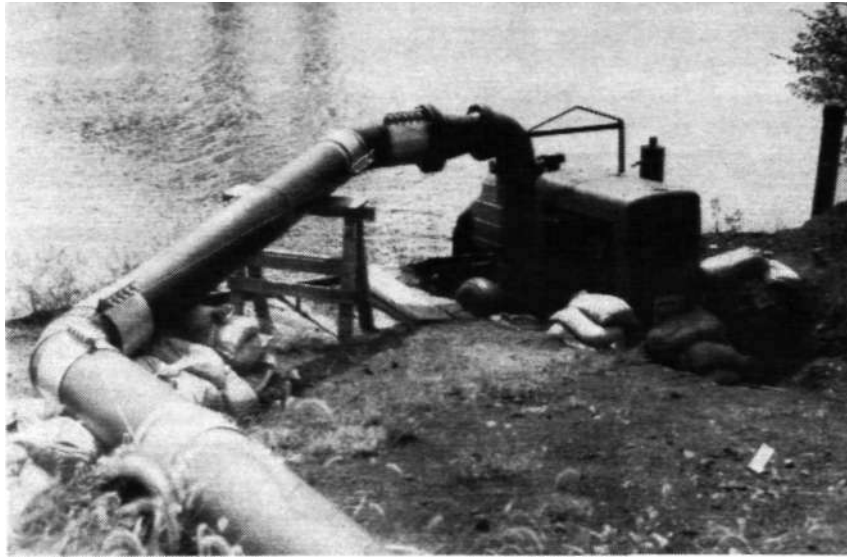

Figure 2. Pump installation at Cedar Street



Figure 3. Pump installation at Cedar Street, showing suction line

standard interlocking couplings was given first consideration. This idea was quickly abandoned when this type of pipe was found to be made only in sizes up to 8 inches—much too small to meet criterion (2). Asbestos-cement pipe was ruled out principally because it has unacceptable head loss characteristics; in addition, it would be difficult to temporarily couple, is relatively expensive, and is only marginally lightweight. A polyethylene plastic conduit was found which appeared to meet all four criteria to some degree. NIPACK, a polyethylene conduit manufactured by ARCO Durethene Plastic, Inc., was relatively inexpensive, lightweight, strong, and very smooth. The plain spigot ends, designed for butt fusing, were amendable for use with some type of compression or band-seal coupling. Based on these considerations, 440 feet of 12-inch conduit was purchased. The specifications and some physical properties of the pipe and material are presented in Appendix B.

The pipe comes in 40-foot lengths. To facilitate handling, hauling, and storing, these lengths were cut into 20-foot sections using a circular saw equipped with a ply-tooth blade. Twenty feet of this pipe weighs only 133.2 pounds, a load which can be managed by two people. Figures 2, 4, and 5 show the conduit system in place and in operation at Cedar.

The polyethylene pipe, while adequate, proved to be considerably less than ideal. Its heat absorbing black color coupled with its high thermal expansion coefficient (see Appendix B) caused excessive diurnal movement, resulting in nightly joint separations. The pipe would heat

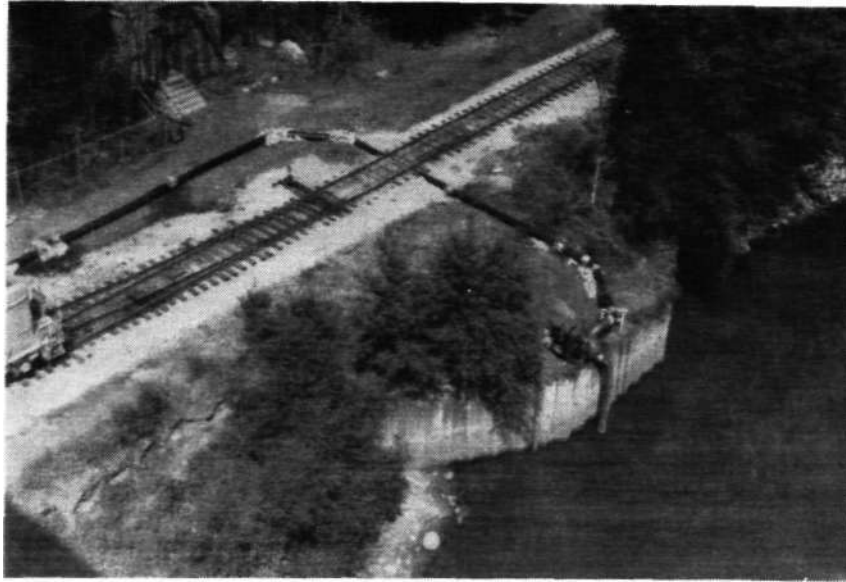

Figure 4. Pump and piping setup

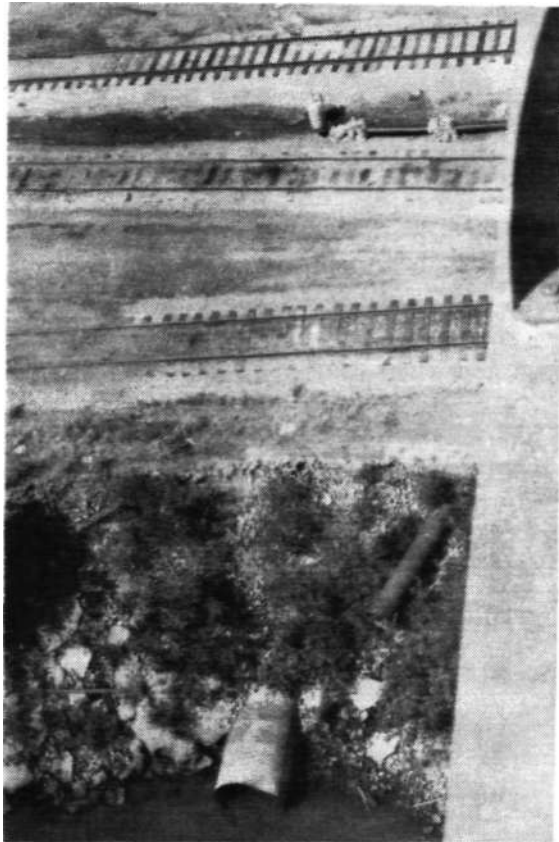

Figure 5. Sewer manhole injection point and river outfall

to 130 to 140°F during the day when assembled and then cool below 70°F at night. For 300 feet of pipe this results in over 20 inches of contraction. Most of this would occur at two or three joints, causing considerable leakage. The problem was partially solved by sandbagging critical joints as shown by figures 4, 5, and 6. Also, as will be discussed later, a newly developed more structurally rigid coupling came on the market after the start-up of the project. Several were purchased on a trial basis, and they proved to be capable of holding the joints more securely than the compression-friction coupling. The sand bags shown in figure 7 at the manhole discharge point were needed for thrust blocking. Unfortunately, this prevented much of the expansion and contraction from being taken up at the terminal end. Any future installation should include design provisions to account for or to minimize thermal induced movement. Spherical rubber expansion joints, such as Holz Spanflexes, should be incorporated into the line at 100-foot intervals.

Another disadvantage of the pipe is that it tended to become deformed both longitudinally and transversely. The 20-foot lengths became bowed or banana-shaped and some sections became elliptical when stacked. This made alignment and coupling difficult and compounded the thermal separation problem.

Even with all the attendant and bothersome installation and operational problems associated with polyethylene pipe, its use was necessitated because of its relatively low head loss characteristics. It has a Hazen and Williams roughness coefficient of 150 versus a

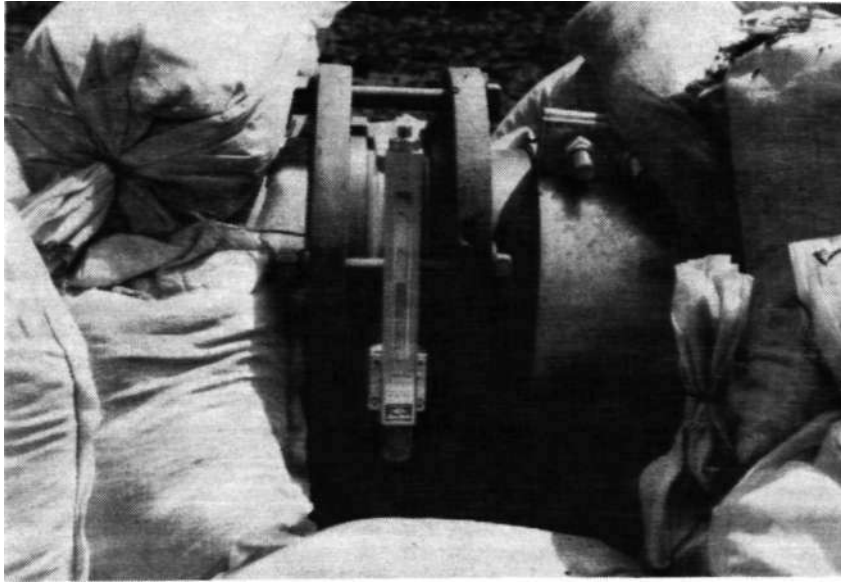

Figure 6. In-line flowmeter



Figure 7. Dye tank and metering pump

coefficient of 100 for smooth new steel pipe. Essentially this means that the polyethylene pipe capacity is 50 percent greater than that of new steel pipe.

The pipe fittings ordered are listed in Appendix B. Some fittings eventually were not used because of defective workmanship or because better ideas were developed, negating the need for certain items. To achieve maximum pump capacity, head loss had to be kept to a minimum. This was done by using 12-inch pipe and was made possible by attaching a 10 x 12 inch concentric increaser (reducer) to the 10-inch pump outlet. A NIPAK polyethylene reducer was purchased at considerable expense, but it was found to be unusable because of defective construction. It proved to be severely out-of-round and the couplings would not hold; a 1.375 -inch wall thickness prevented conformity to roundness even when the coupling was tightened excessively. A steel increaser had to be purchased and adapted to the system, as shown in figure 2. It proved satisfactory but added almost 300 pounds to the pump weight, reducing the stability of an already unstable unit. Since the steel increaser was bolted directly to the pump, a 12-inch flange adapter had to be used with the increaser to provide a means of attaching the spigot-end plastic pipe.

Forty-five degree elbows were used at all direction changes. This reduced head losses and minimized momentum forces on the fitting (see figures 2 and 4). Sand bags were used for thrust blocking at the corners. The piping had to be tunneled under the railroad tracks as shown in figure 4. The pump vendor recommended running the pump only at

full throttle since it was designed to do so and anything less would cause excessive wear and overheating of the diesel engine. The plan was to install a capped tee in the system and uncap it when reduced flows were desired. The need to do this did not materialize. The pumping rate could be reduced by throttling down the engine without creating mechanical problems - in fact, the engine ran cooler and consumed only 25 percent as much fuel at a 1600 gpm pumping rate.

In-Line Appurtenances

The selection of couplings, a flow metering device, and a suction line hook-up were important considerations. A large number of couplings were needed. In addition to being applicable they had to be economical, easily assembled, and conveniently stored. The specifications for the products used are listed in Appendix B.

Couplings. Morris brand compression couplings were selected for use after - a trial pumping demonstration was successfully completed using them. The Morris Coupling Company was the only firm which expressed any degree of confidence that their product would work when attached to smooth plastic pipe. Three other manufacturers were contacted, but they were very noncommittal as to whether their couplings would work under the envisioned study conditions.

The standard Morris compression coupling consists of three parts, as shown by the photograph in Appendix B. The innermost part is a split red rubber gasket fitted with square-tooth grooves; the middle part is a heavy-gage, zinc-plated, split steel sleeve fitted with square-grooved

interlocking teeth; and the outer shell is a split compression ring, flanged and bolted at the split. These basic couplings were used at most of the joints. Also, four newly marketed side band couplings were used. These couplings include dual locking side bands which vastly increase axial force holding power (see photograph in Appendix B). These couplings were placed at critical points in the discharge lines where stresses and axial momentum forces were the greatest.

A slight modification had to be made to each coupling before use. The square-grooved teeth in the sleeve had to be ground slightly to prevent permanent interlocking. The couplings are actually designed to remain in place after installation. Once an unmodified coupling was completely tightened and the teeth became interlocked, removal without damage was impossible.

Considering the thermal movement of the pipe, the modified standard couplings worked satisfactorily. Fewer problems probably would have been encountered if side band models had been available for use throughout. Sandbagging would certainly have been minimized. However, in the immediate area of the pump discharge, even the side band units started to separate after the fourth run since the piping in this area is not continuously supported and is subjected to maximum kinetic forces. Total separation of the joints near the pump was prevented by interlocking each coupling via a network of cables and turnbuckles (see figure 2).

Flowmeter. Flow was measured using an AquaMatic Flowcell flowmeter as shown in figure 6. This meter operates by measuring the pressure

loss across a knife-edged restriction. The meter was custom-made to fit the range of flows envisioned for this study. The general specifications and the specific rating criteria for this meter are presented in Appendix B. This meter worked very well at all times; however, it is not ideally suited to this study since it operates on the principle of differential pressure. Note from the specifications that over 3 psig (7 feet of head) is lost at high flows. The use of a flowmeter featuring considerably less head loss, such as one using the ultrasonic principle, would probably have been more desirable. The cost of an appropriate ultrasonic meter was, however, about three times that of the one purchased.

Suction Lines. Two used 13.5-foot lengths of 10-inch braided rubber suction hose were purchased. Purchasing used hose saved money initially, - but eventual repair costs reduced this saving considerably. The hose developed small air leaks in areas where it had been severely crimped, and the flange welds, being corroded, developed stress cracks which resulted in leaks.

A 14-foot section of suction hose weighs over 600 pounds, which means attachment to the pump is difficult since the bottom of the intake flange is 30 inches above ground level. To facilitate the attachment, an A-frame cradle was fabricated of 1/8" x 1-1/2" x 2" angle iron and equipped with three 2-ton cable hoist jacks to lift the hose and align the flange bolt holes.

The suction hoses had to be secured to the pump on level ground before the pump was maneuvered into its final river bank position.

Dye Injection

Rhodamine WT was the dye tracer used. The dye specifications are presented in Appendix B. The manufacturer states that the dye color was developed to produce a high tinctorial strength and a low tendency to adsorb on silt, dirt, and other suspended matter in shallow and inland waters. However, some recent evidence from studies by Bencala et al. (1983) indicates that this may not be true. They found that up to 55 percent loss occurred in shallow mountain streams. Laboratory experiments showed that streambed sand and gravel sediments have an appreciable capacity for Rhodamine WT sorption. The consequences of this relative to this study are probably minimal, though, since water depths greater than 10 feet persist in the upper 2000 feet of the study area. In the lower 2000 feet, extensive shallows less than 2 feet deep exist, and this could affect the result.

The dye injection system shown in figure 7 consists of a dye storage tank, a metering pump, and a storage battery. The dye storage tank is a 65-gallon plastic cylinder, 24 inches in diameter and 40 inches high, specifically designed for mixing and storing corrosive chemicals. A spigot on the bottom side wall was fitted with a 1-1/2-inch plastic ball valve reduced to accept 3/8-inch plastic tubing. The drum was calibrated in 8-liter increments up to 256 liters.

The dye metering pump is a Fluid Metering, Inc., rotating and reciprocating piston pump specifically designed for accurate handling of corrosive liquids. The pump piston, cylinder case, and cylinder liner materials, respectively, consist of alumina ceramic, 316 stainless

steel, and sintered carbon. The discharge was fitted with a micrometer flow adjustment kit which allowed precise stroke adjustments of 0.1 percent. The pump was calibrated over the total range of positive suction heads expected to be experienced during a run. The results are presented in tabular form in Appendix B. Two things are noteworthy relative to calibration results. First, the pumping rates observed over the range of positive suction heads were significantly higher than the manufacturer's rating. Second, the observed pumping rates for each positive suction head were essentially equal up to an approximate micrometer setting of 0.6 (450 ml/min manufacturer's rating). Above 0.6, the rates diverged sharply—the higher the head, the higher the discharge rate. To minimize variability in dye injection quantity, the pump micrometer was set at 0.2 for all runs and the dye-to-water dilution ratio was varied to meet minimum desired river dye concentrations.

A 165 amp RV/marine deep cycle battery was used to power the dye injection pump. The pump draws 4 amps per hour; thus the battery can sustain 25.6 hours of continuous pump operation without recharge at this rate of current usage.

Sampling Equipment

The development of a sampling strategy proved to be a challenge. The literature contained very little information or advice. However, good methodologies were developed and unique equipment was fabricated and/or assembled which worked beyond expectations. Details will be presented here which may be helpful to other investigators.

A sampling scheme had to be developed using equipment that: (1) was simple and reliable so as to minimize operational problems; (2) provided rapid, repetitive samples—600 sample collections were necessary per run; (3) contained mechanisms, parts, and conduits which were immune to dye absorption; and (4) was affordable.

The controlling factor in designing the sampling program was the need to collect a large number of samples. Six hundred field sample collections per run were deemed the minimum needed.

This number was developed from many considerations, principally those involving the limitations of field and laboratory personnel and equipment and the need for an adequate data base. For example, a rational assumption was made initially that at least two minutes were required to collect one sample. If, say, 1200 samples were to be collected, then at least 40 total hours of sampling time would be needed. To make this practical at least eight boats and sampling crews would be needed. However, only four boats and crews were available. Therefore, the goal was set to collect 600 samples. This number also fit into the time constraints imposed for analyses in the laboratory—all samples were to be analyzed within 24 hours of collection.

After a number of alternatives were considered, a field sampling procedure based on pumping was devised. A schematic view of the system is presented in figure 8. A sampling hose connected to a pump and attached to a fishing downrigger provided a simple, reliable, and rapid means of sampling. The downrigger, equipped with a depth counter,

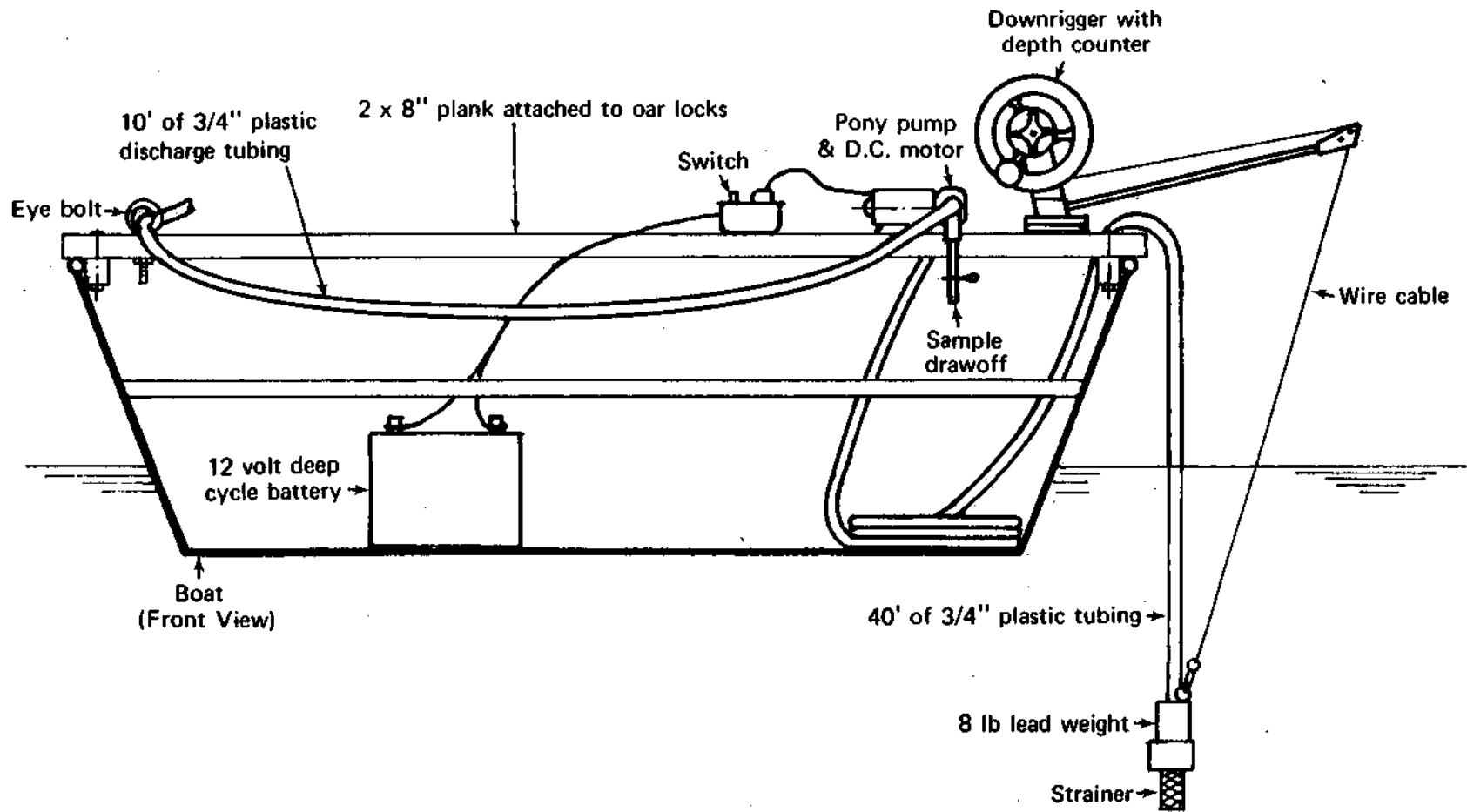

Figure 8. Schematic of boat equipped with dye sampling set-up

provided precise sampling elevations and permitted quick and easy adjustments to changing water depths. The pump discharge was equipped with a plastic tee with 5/16-inch PVC drawoff tubing with a pinch clamp affixed. A 105 amp RV/deep cycle battery was connected to a switch/plug box conveniently located for controlling the flow. A waste line from the tee was threaded through an eye-bolt on the opposite side of the boat so that the discharge would be at the opposite side of the boat or at the transom, thereby minimizing disturbances in the sampling area. A 2 x 8 plank, secured with bolts through the oarlock holes (on three boats) or through inside handles (on the fourth), was used to position the equipment. Wing nuts secured all items, making it easy to quickly remove the board from the boat or any item from the board.

The downriggers were Big Jon Model D476 right-hand units equipped with 200 feet of 150-pound test stainless steel line. The footage counter could be read within a half foot.

The pumps were D.C. powered Model 365 Proven Pony pumps. The specifications are listed in Appendix B. The impellers are rubber and are extremely susceptible to stoppage by coarse sand and small pebbles. To minimize the intake of solid materials, fine mesh screens were fabricated and fitted in the bottom end of the suction line.

The tubing or hose had to be carefully selected. It had to have a low dye adsorption affinity, and it had to be smooth to minimize sampling time; i.e., the lower the head loss, the quicker the flushing rate. Ordinary 3/4-inch rubber or vinyl garden hose will not suffice. Both produce excessive head losses and both readily adsorb fluorescent

dye. A search was conducted to find a suitable conduit. Eventually five different types of tubing were tested to determine the dye adsorption characteristics of each. Nalge 3/4-inch 8000 PVC tubing was selected for use. A 40-foot length was used for suction and a 10-foot length for discharge. Standard 3/4-inch female garden hose connectors were used at the pump inlet and outlet. Eight pounds of lead were molded into an annular shape and slipped over the end of the suction line above the strainer screen for line weight as shown in figure 8.

To efficiently and effectively conduct the study, sampling time had to be kept to a minimum. Time savings of a few seconds per sample collection translates into hours of savings overall because of the hundreds of collections needed during a complete run. The discharge characteristics of the pump, under head losses associated with field conditions, greatly influence this time element. Higher discharge rates reduce flushing time intervals; therefore, waiting periods between sample collections are shortened. The flushing time of the sampling system was determined in the laboratory using simulated field conditions. The pump inlet was placed about 30 inches above the top of a constant head tank, the suction line fitted with a strainer, and the discharge measured in a volume displacement tank. The experiment indicated that approximately 16.5 seconds would be required for one flushing. In the field, a 30-second wait was actually utilized to insure a factor of safety.

Only small boats were considered satisfactory for use in sampling, since larger boats powered by large outboards would be hard to manage

under the confines of the closely spaced sampling points. More important, the rigid constraints designed into the sampling plan precluded the use of gasoline-powered outboard motors. Excessive turbulence would be generated, and the exhaust emissions might contain oil and/or fluorescent compounds which could cause sample contamination. Four relatively small boats, powered and controlled by electric trolling motors, were used. These consisted of three flat bottom boats 14, 16, and 18 feet in length and a 14-foot semi-vee craft. The trolling motors were Minn Kota Model 65C's. The motors were carefully selected in a compromise between electric power draw requirements and thrust production in pounds. The overall specifications are presented in Appendix B. The motors were operated using 130 amp RV/marine batteries independent of the ones used to power the sampling pumps. Reference to the power specifications tabulated for the motors in Appendix B shows that full throttle (speed setting 5) operation draws 25 amps and limits the battery power to about two hours. Conservative and judicial operation was required during the sampling time period. Figure 9 shows the fully rigged 18-foot flat bottom boat being maneuvered into sampling position using the trolling motor.

Samples were collected in 20-ml Wheaton 180 glass liquid scintillation vials. Twelve 100-lot cases were prepared for field use. A typical arrangement is shown in figure 10.

Laboratory Equipment

A Turner Model 110 fluorometer equipped with a 546-nanometer primary

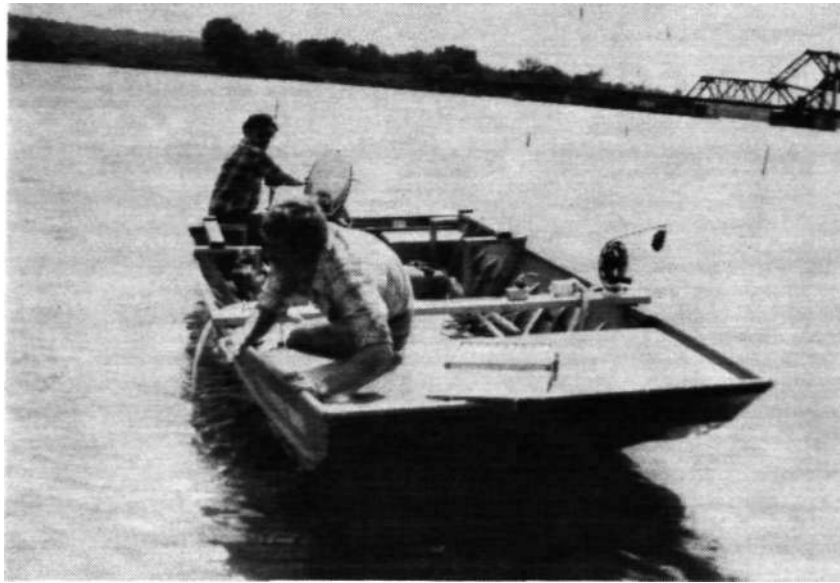

Figure 9. Sampling boat 4, showing stakes in background



Figure 10. Sampling bottles in carrying case

filter and a 590-nanometer narrow bandpass secondary filter was used to analyze samples in the laboratory. A YSI Model 46 TUC Tele-Thermometer was used to monitor sample temperatures during fluorometric testing. The 12-volt RV/marine batteries were recharged by Sears Model 608.718420 10-amp battery chargers equipped with timers. Battery recharge times were determined using a direct-reading, temperature - adjusting hydrometer.

Operating Procedures

A complete sampling run involved three distinct field operations. First, prerun river hydraulic conditions had to be ascertained and evaluated. Second, overflow simulations had to be designed or tailored to fit river hydraulic conditions. Third, coordinated river sampling had to be accomplished.

Prerun Preparation. Site selection for a given run (as previously discussed) was limited to one of three locations: State, Oak, and Cedar. State, with its two types of outfalls, was chosen for the initial trial. A concerted effort was made to establish overflow simulation here, but doing so was eventually found to be impossible. A platform, suspended between two trees, was extended toward the river to provide placement of the pump within what was thought to be an adequate distance from the water edge to effectively provide suction. The vertical lift was only 14.5 feet at normal pool stage, but the suction line had to be laid on a slope for approximately 26 feet. Consequently, the strainer just barely reached the water's edge using the two available 13.5-foot suction

lines. A third 12-foot cast iron segment was secured and lowered into place. Air leaks in the steel flanges and hoses were fixed. These improvements allowed the pump to be primed, but the resultant discharge was very small. Nothing more could be readily done to increase the output. This necessitated moving to another site. The only logical one left was the Cedar site since the physical setting at Oak was identical to that at State.

The pump was moved to Cedar. A 30-inch-deep hole was dug and the pump lowered into it (see figures 2 and 3) using a 4-ton portable chain hoist. Lowering the pump 30 inches allowed the use of only one suction hose, thereby making the situation more manageable. Approximately 11.5 feet of lift was needed for the set-up shown in figure 3.

On a day preceding a run, the time period required to reach steady state conditions for a given sampling reach under specific hydraulic conditions was determined. This was done by injecting a slug of dye at a point in the river at the sewer outlet and positioning a sampling boat at a downstream location. Samples were collected at 15-minute intervals at points 25, 50, and 100 feet from shore until the peak dye concentration passed. The curves generated at station 61+00 prior to the first Cedar Street run are presented in figure 11. Note that the time of passage for the peaks at 25 and 50 feet lags behind that for the 100-foot peaks by at least 1.5 hours. Over 3.25 hours were needed for steady state conditions to develop in the shallows approximately 3000 feet below the Cedar discharge. Extending this to 4000 feet requires a total of 4.25 hours. Adding to this a factor of safety of 1 hour and

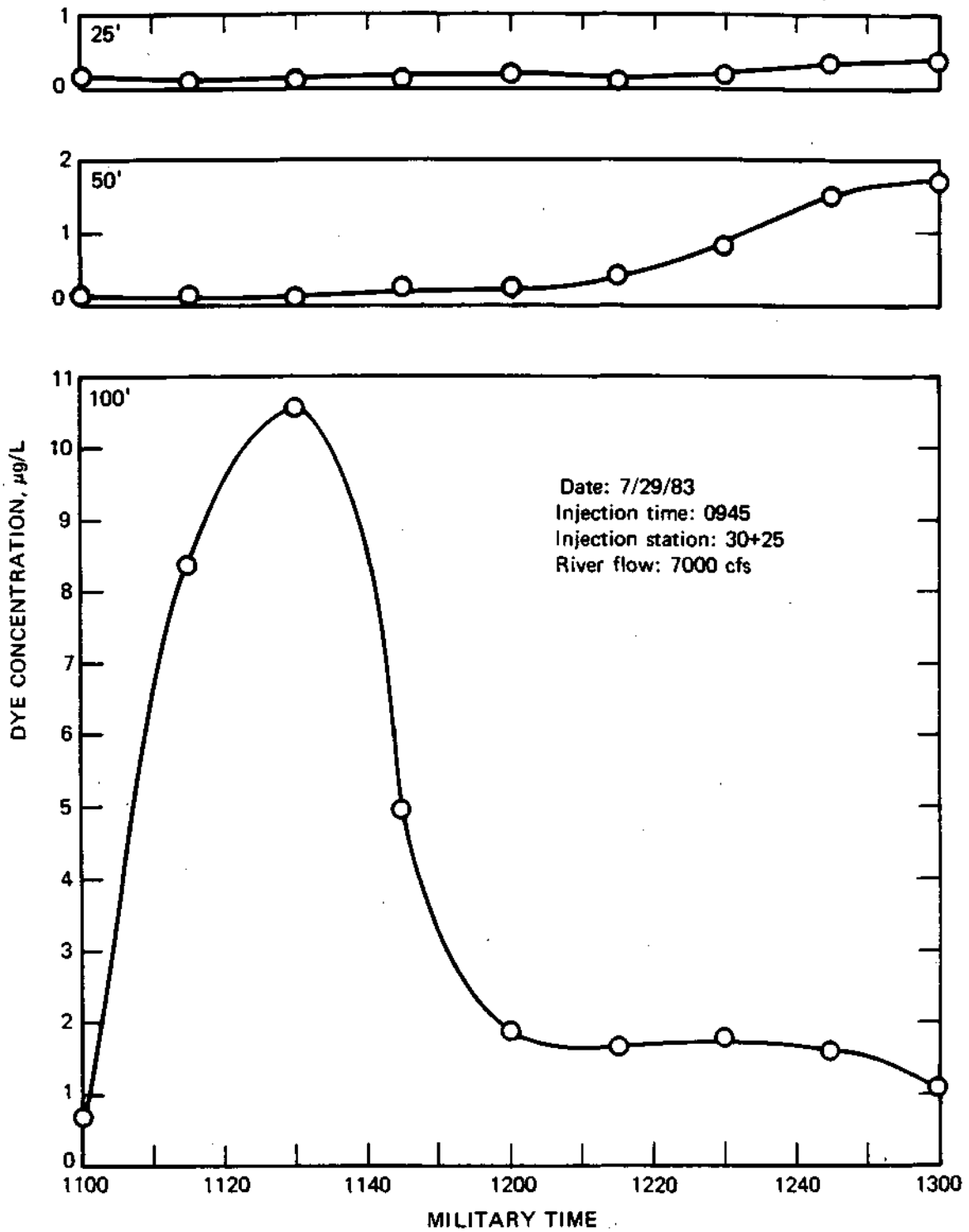

Figure 11. Time versus dye concentration at station 61+00 with dye injection at Cedar

allowing for a 3-hour sampling period, a total dye injection time of 8.25 hours was required during river flows of approximately 7500 cfs.

Cobb and Bailey (1965) present a formula for computing the dye volume needed during a run for a known injection time:

$$V_d = 102,000,000(C_2/C_d)Qt_t \quad (1)$$

where V_d = dye volume in milliliters, C_d = dye concentration in micrograms per liter, C_2 = desired sampling point dye concentration in micrograms per liter, Q = stream flow in cfs, and t_t = injection time in hours.

The use of equation 1 in this study becomes difficult, however, since only that portion of the stream flow which falls within the mixing zone plume can be used. The determination of this mixing zone flow before the study was started had to be attacked strictly on an a priori basis. In view of this, a theoretical formula presented by Hubbard et al. (1965) was used to estimate the average mixing plume width:

$$L_m = (0.2vW^2) / [d^{1.5}(gs)^{0.5}] \quad (2)$$

where L_m = length in meters to effect complete mixing for a bank discharge, v = average velocity in m/sec, W = channel width in meters, d = average depth in meters, g = acceleration due to gravity (9.81 m/sec/sec), and s = water surface slope. Using this equation somewhat out of context and by assuming certain stream conditions, a rough approximation of the average plume width can be ascertained. Channel cross sections at about 400-foot intervals obtained from the Corps of Engineers were used to calculate the average depths and velocities for use in equation 2; the equation was then solved for W by setting L_m

equal to 4000 feet. The resultant W-value was taken to represent one average plume width. It was assumed that at 4000 feet below Cedar the dye would be very dilute and fairly evenly dispersed within the plume at that point; i.e., complete mixing would occur within the plume, although not in the total cross section.

The resultant W-values for 7500 and 15,000 cfs were 110 feet and 120 feet, respectively. To these, 50 feet was added as an allowance for jettison at the outfall. Consequently, the average outward extension from shore would be 160 feet for 7500 cfs conditions. This distance represents approximately 12 percent of the average cross-sectional area. The average velocity in this area was set at 85 percent of the average total cross-sectional value per a USGS recommendation. Flow within the mixing area was then calculated using the continuity equation ($Q = VA$) for use in equation 1.

Solution of equation 1 for 7500 cfs involved the following input: $C_2 = 2.5$ micrograms per liter, $C_d = 200,000,000$ micrograms per liter (20 percent solution), $Q = 778$ cfs, and $t_c = 8.25$ hours. These values indicated that about 8 liters of dye would be needed for the first run. Since the metering pump test showed that an injection rate of 240 ml/min (0.2 micrometer setting) was best, the proper dye-to-water dilution had to be determined so that the proper amount of the active dye ingredient would be injected. A significant amount of diluted solution remained after each run. This was reportioned for use during the next run.

The dye volume and dilutions were all made up on the day immediately

preceding a scheduled run. The Kingston Mines gage on the river was read and the river flow was used to estimate dye quantities and dilution requirements.

Overflow Simulation. The pump and piping, once installed at Cedar, were left in place for the duration of the study. On the day of the run, the pump was started up between 6:30 and 7:00 a.m. The engine was throttled to achieve the desired flow rate, and checks were made for leaks. If some were found, the sand bags were removed from all joints and the couplings at the leaking joints were removed. The piping was then refitted to close the separations, the couplings replaced, and the sand bags reapplied. Minor leaks were tolerated.

The maximum pumpage that could be achieved at full throttle at normal pool elevation was 3400 gpm. However, by throttling the diesel back slightly to produce 3200 gpm, a significant reduction in noise was achieved and some fuel was saved.

Once the discharge line appeared to be stable and major leaks were stopped, the dye injection pump was started. The dye was trickled directly into the overflow simulation discharge stream at the manhole (see figure 7). Turbulence within the stream was sufficient to promote complete mixing although the manhole was only about 100 feet from the river. A person was left on duty for the duration of the run to monitor the discharge pump and dye injection system. The system was shut down immediately upon completion of the sampling. The pump monitor and one of the sampling crews maintained contact throughout a run via two-way marine radios.

Sampling. Six hundred samples were collected per run. Four boats rigged for sampling, as shown in figure 8, were used to accomplish this. Each boat was responsible for collecting 150 samples. Sample collection locations are shown in figures 12a and 12b. Some minor adjustments were made during the course of the study to reach assignment limits, but basically, collections were made by boat 1 between stations 29+75 and 35+00; boat 2 between 36+00 and 46+00; boat 3 between 47+00 and 56+00; and boat 4 between 57+00 and 70+00. The collection points at downstream locations were spread over wider distances—laterally, longitudinally, and vertically—than those at upstream locations. The dots in figures 12a and 12b represent 25-foot lateral increments. Near the outfall, lateral collections were made to 100 feet, while at station 70+00 the outer limit was 200 feet.

Initially all sampling points were marked with floats. Setting them involved the use of four boats, and this proved to be a cumbersome, time-consuming procedure which facilitated sampling very little. Subsequently, a more efficient, more manageable system was devised as demonstrated by figure 13. Above station 36+00, gallon bleach bottle type jugs, marked with the station numbers, were set at every station 75 feet from shore; small inflatable quart floats were set 50 feet from shore at alternate stations only. Between 35+00 and 57+00, where sampling was increased to 125 feet, the gallon floats were set at 100 feet at each station while the quart floats were set at 50 and 75 feet at alternate stations. The boat operator used the available markers to line up unmarked positions and to estimate distances. From 57+00

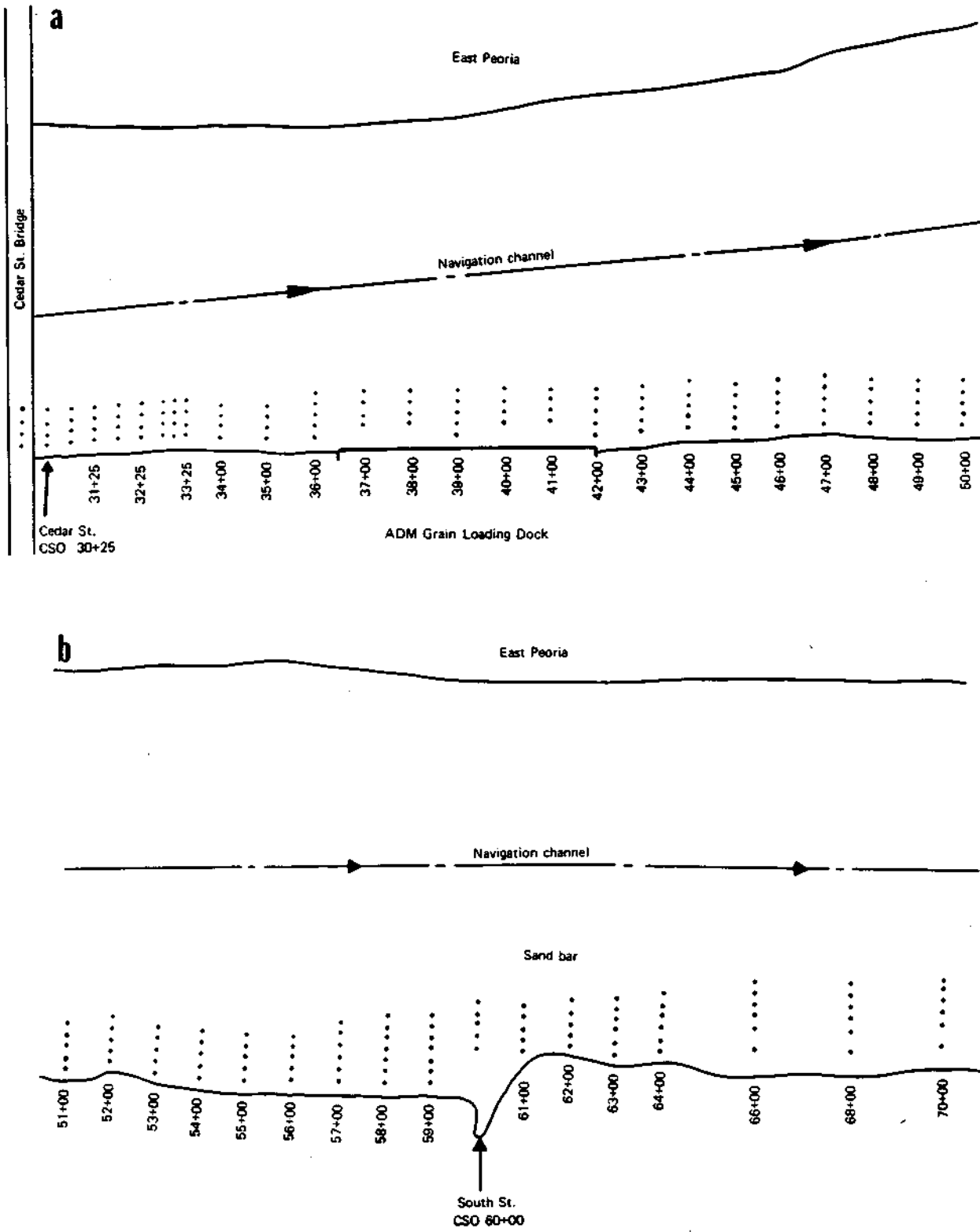

Figure 12. Plan view of sampling locations

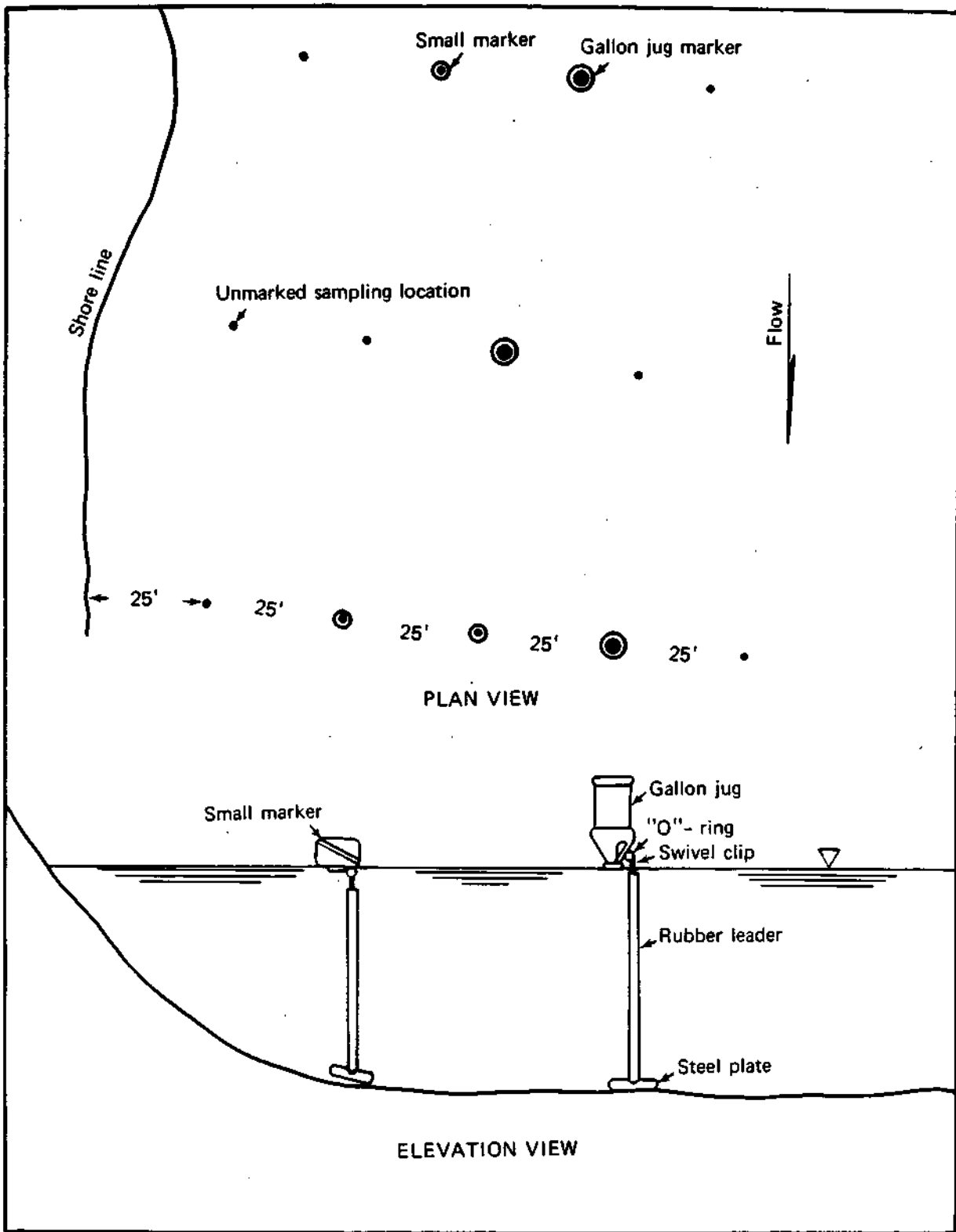

Figure 13. Schematic of sampling marker location set-up

through 70+00 all sampling locations were permanently marked by driving 2" x 2" stakes into the bottom. Figure 9 shows some of these stakes in the background.

The floats were set using a USGS graduated tag line as shown in figure 14. All floats were removed at the completion of a sampling run. Significant losses were incurred from barge activity and wind action. Initially, 16-ounce lead weights were cast and used as anchors. However, these proved to be unsatisfactory and were replaced with 1/2" x 8" x 12" steel plates. Rubber leaders, cut from innertubes, were used to minimize line tangling and to circumvent the need for winding for storage.

A few samples were collected on a trial basis using a split image range finder for location spotting. This method appears to be an attractive alternative to using floats. Certainly the use of range



Figure 14. Setting markers using tag line from shore

finders, in conjunction with a limited setting of floats, requires less work, is more expedient, and is just as accurate as using floats and eye positioning.

The floats were set shortly after overflow simulation pumping was started. This was done early to minimize disturbances within the plume by boat movement.

Sampling usually commenced between 1:00 and 2:00 p.m. A sampling crew consisted of a boat operator and a sampler. A definitive collection procedure was developed and strictly adhered to for all runs. The procedure was designed to minimize the overlapping influences of repetitious sampling using the same pumping system and to minimize disturbance within the sampling zone. Sampling was initiated at the lowest theoretical dye concentration point in each of the four sampling areas, i.e., the bottom or lowest elevation, on the farthest vertical from shore, on the last station. Thence, sampling was to continue by sampling from the bottom to top at all verticals, from the outside vertical to the shore side vertical, and from the most downstream station to the most upper. Once the shore side vertical was sampled, the boat proceeded by moving to the outside vertical on the next upstream station. The idea was to progressively sample higher concentration areas on the theory that accumulative or progressive sample contamination would be minimized because each new sample had a higher dye level than the preceding one.

A surface sample was collected at all verticals, and where the depth was 10 feet or greater, samples were generally collected at the surface,

3-feet, mid-depth, and bottom levels. When the depth was less than 10 feet either surface, mid-depth, and bottom collections or just surface and bottom collections were made depending upon location. In areas less than 3 feet, only a surface collection was made. Near the outfall some selected verticals were sampled every 1 to 2 feet. Also, as shown in figure 12, transverse stations were established every 50 feet for the first 300 feet below the outfall, and 200-foot spacing was used below 64+00.

A standard field sheet was designed to minimize note keeping and decision making during the actual sampling operation. The form is presented as Appendix C and is shown with predesignated sampling locations and depths. This example is typical of one of two given to each boat crew before each run—in essence, it represents precise and orderly sampling instructions. One blank space indicates that a bottom sample is to be collected, whereas two blank spaces indicate that a mid-depth and a bottom collection are to be made.

Figure 15 shows all four sampling boats in position; the outfall is just out of the picture to the lower right. Over the course of the study sampling time was reduced from four hours to less than two as a result of improvements in sampling efficiency.

The sampling program was designed to handle two successive days of operation. Therefore, each boat was assigned three cases of sampling bottles with each case containing 100 containers as shown in figure 10. A staggered numbering system was used for cases 1 and 2 so that the first 50 samples from each boat could be returned to the laboratory for

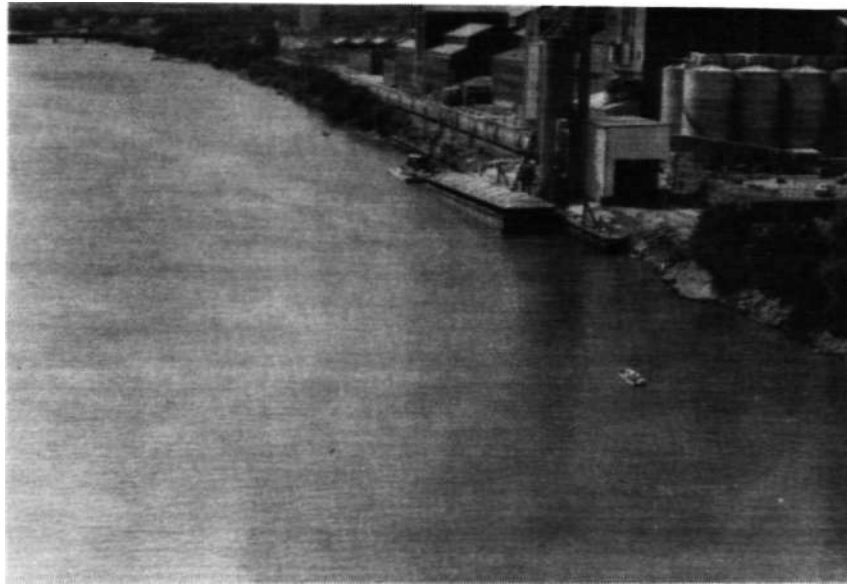

Figure 15. Study area, showing boats in sampling positions

early analytical examination without disrupting the sample numbering continuity during successive days of sampling. For example, case 1 of boat 1 contained 100 bottles numbered 1-50 and 151-200. Case 2 contained 100 bottles numbered 51-150, and case 3 contained 100 bottles numbered 201-300. During the first day bottles 1-50 were filled as well as those in case 2. Case 1 was returned to the field so that a second day's run could be made using bottles 151-200 in conjunction with those numbered 201-300 in case 3. The bottles were stored in the cases with the tops down because the caps' design prevented the taping of numbered labels in an upright position (see figure 10).

Upon completion of a run, the sampling lines were attached to an outside sillcock at the laboratory and flushed for ten minutes and then completely drained. Care was taken to store the conduit without

pinching or crimping any portion of it. This procedure was not followed during the first two runs—lines were crimped, trapping river water contaminated with dye. The clear plastic hose adsorbed the dye, producing a pinkish color in the crimped area. Even the lines for boat 4, operating in an extremely diluted dye area, produced pinkish tinges where river water had been trapped. However, tests showed that although the plastic hose readily adsorbed the very low dye concentrations from trapped water, leaching from the hose to uncontaminated water did not occur.

Laboratory Procedures. River samples were returned to the laboratory and left undisturbed for a time to allow all the sample temperatures to stabilize at room conditions. During analyses, temperatures were continuously monitored and recorded for both the river samples and standard dye solutions.

On the day of a run, a grab sample was collected near the pump intake prior to start-up to be used for background fluorescence corrections.

Standard Rhodamine WT dye solutions, ranging from 0.2 to 75.0 micrograms per liter, were prepared using double deionized water. For sample analyses the water background sample and a range of standard concentrations were read and recorded for each fluorometer aperture change. If an aperture change was not required within an hour, the procedure was checked by rerunning the same set of standards.

Concentration versus fluorometer reading curves were developed for each of the 1x, 3x, 10x, and 30x aperture settings using least square

linear regression techniques. Temperature corrections were made using the correction coefficients presented by Cobb and Bailey (1965).

DATA ANALYSIS PROCEDURES

The sampling program was designed to generate a very large quantity of relatively accurate, precise data. The analysis of this data, relative to defining a mixing zone, can be approached several ways. Mathematical modeling techniques based on theoretical concepts involving dispersion coefficients can be used and are, in some ways, the most desirable approach. The development of a conceptual model has the advantage of flexibility; i.e., once the model has been developed, calibrated, and verified, it can be used to predict or define outputs for a wide range of conditions. For instance, if dispersion coefficients can be calculated using field information gathered under specific sewer and river hydraulic conditions, these coefficients can be used to evaluate or define the extent of mixing for other hydraulic conditions. Unfortunately, no clear-cut methodology or algorithm has been developed and published to facilitate such predictions. One of the objectives of this study was to generate quality data in quantity for use in the future development of a conceptual mixing algorithm.

The problem of defining or predicting a mixing zone can also be approached pragmatically using basic engineering concepts and judgment. To fulfill the immediate needs of this study, a rational approach will be taken for reducing the data into a form amenable for use in defining a mixing zone.

Conceptual Approach

Time constraints precluded the development and use of a conceptual

model. However, considerable thought was given to the subject and the need to formulate a methodology applicable to the study conditions. Almost all existing mixing and dispersion models are applicable only to streams having uniform channel cross sections and longitudinal profiles. Examination of figures 16 and 17 shows that neither are uniform in the study area. In effect, this severely reduces the applicability of published mixing and dispersion equations to the study situation.

Because of the extreme physical variability within short reaches of the study area, lateral, vertical, and longitudinal mixing rates will vary greatly. A systematic conceptual approach has been conceived which will provide a basis for future examination of complex mixing phenomena such as those encountered during this study. Basically the concept involves constructing dye concentration contours at 1-foot depth intervals and using these contours to develop lateral concentration profiles. The points on these profiles will then be fitted to a theoretical Gaussian distribution model proposed by Fischer et al. (1979). This model is a modified form of that presented by Neely (1982):

$$C_{xy} = [M/(du(12.57D_y x/u)^{0.5})]x \exp^k \quad (3)$$

where C = the conservative parameter concentration at a point x , y downstream of a bank discharge, M = mass discharged per unit of time, u = average velocity, d = average depth, $12.57 = 4 \pi$, D = lateral dispersion coefficient, x = longitudinal distance, y = lateral distance, and $k = -(y^2u)/(4D_yx)$.

Theoretical concepts dictate that bank discharge dispersion will

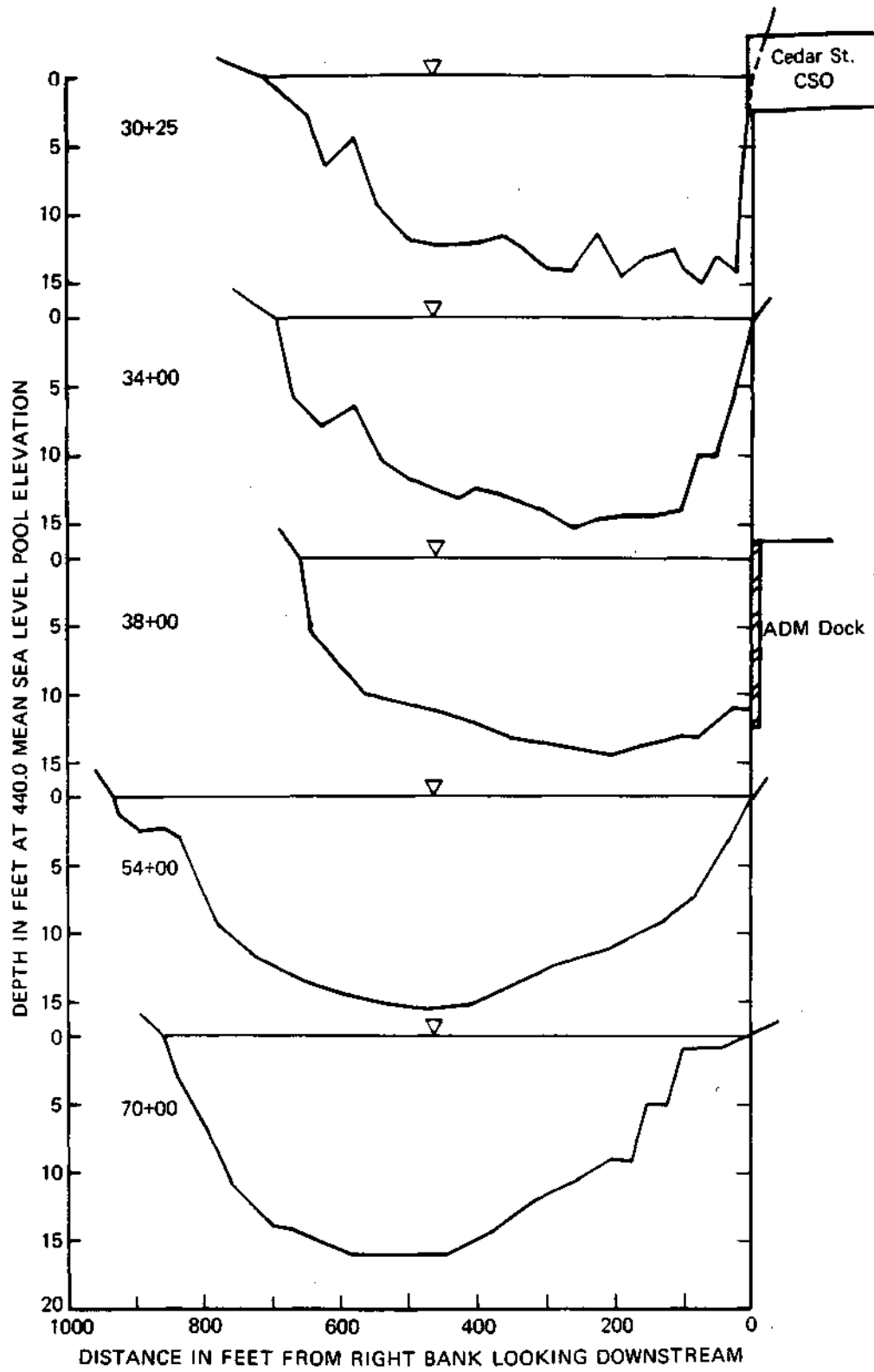

Figure 16. Illinois River cross sections below Cedar Street

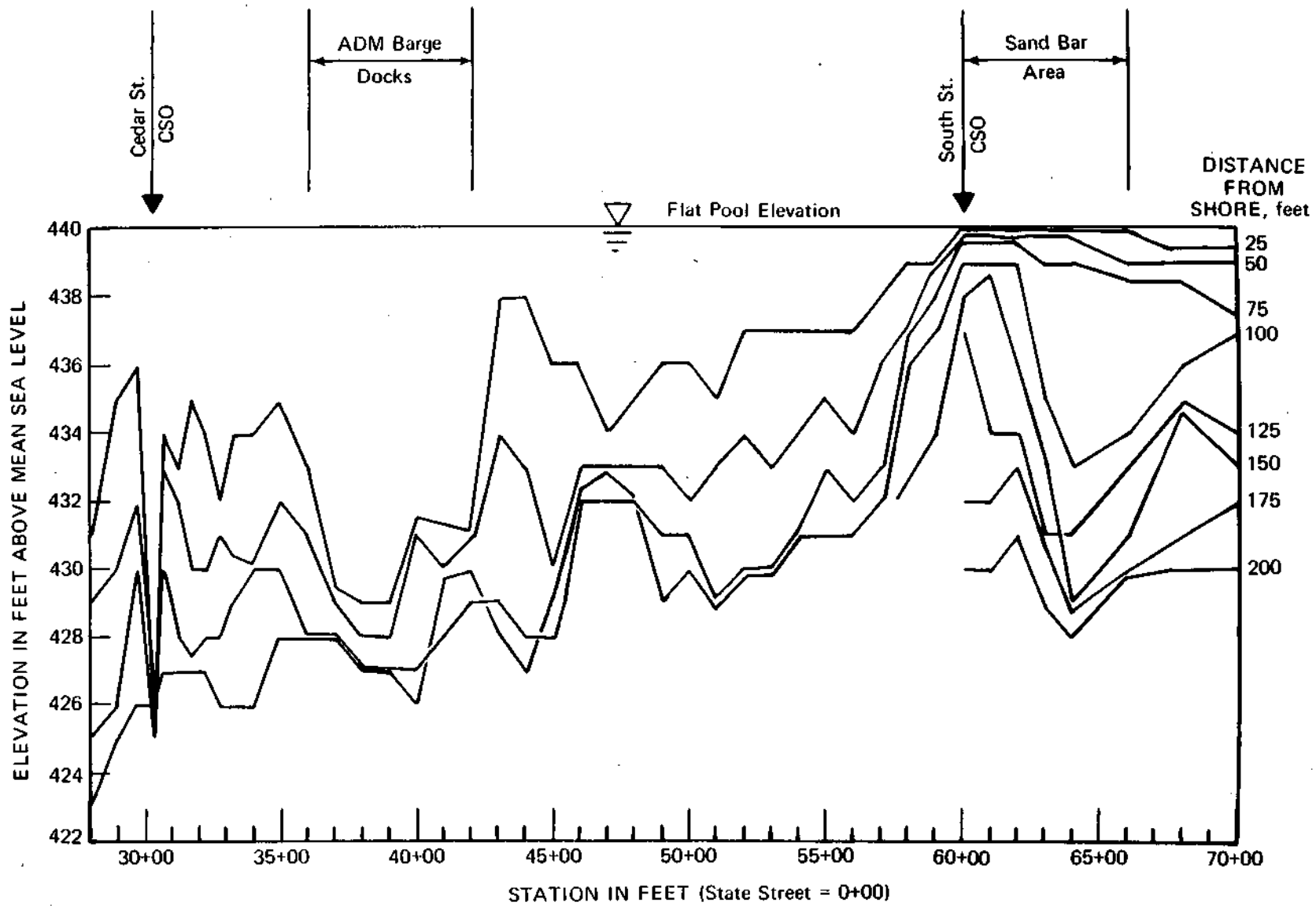

Figure 17. Bottom profiles below Cedar Street

mathematically describe a half Gaussian curve if the channel section is uniform throughout and the flow steady and uniform. Equation 3 describes a two-dimensional form of this concept; vertical dispersion is neglected on the basis that it is insignificant compared to that in the lateral and longitudinal directions. By contouring the dye concentrations, many data sets can be made available at a given cross section for use in equation 3. By developing some iterative computer solution to equation 3, hundreds of spontaneous lateral dispersion coefficients can be generated for statistical evaluation. It is hoped that this will lead to the development of a methodology for predicting mixing in a nonuniform channel.

A limited number of contours of dye concentrations have been plotted on a preliminary basis using the University of Illinois computer facilities and support devices. The software used was DI-3000, a product of Precision Visuals, Inc. (PVI). The PVI Contouring System subroutines were used to draw the plots using a ZETA 1453B plotter. The raw data input to DI-3000 used algorithms of Akima (1978) and of Lawson (1977). One algorithm divides the x-y plane into triangular cells. The other algorithm applies a bivariate fifth-degree polynomial in X and Y to generate the array of gridded data required for contouring.

The PVI program generates contour-line points by linear interpolation between adjacent grid values. These raw contour-line points go through a splines-under-tension curve-fitting process producing smooth contour lines. These contour lines are forced through each of the original interpolated points.

The user has options available for control of the program. One useful option allows the user to contour any part of the data set. Another useful option lets the number and values of the contours be chosen.

The contour outputs generated thus far using this program have displayed some anomalies which are being eliminated. Modifications to the program have had to be made in a progressive manner because the software was designed to accept topographic elevations as input, and not water quality parametric data. The limited number of contour plots, which will be presented later in this report, have been produced manually using straight line interpolation and engineering judgment.

Rational Approach

At most vertical sampling locations a maximum of four samples were collected, except in the immediate area of the outfall where some were taken at 1-foot intervals. Straight line extrapolation was used to estimate concentrations at 1-foot increments between the measured values. This approach for expanding the data base to all water depths produced consistently good results, as shown by the data included in table 2. The measured values in the table are shown in parentheses; the others are extrapolated.

The surveying base line, the shore line, and all sampling locations were plotted with reference to the Illinois State Coordinate System (Anderson, 1949). The sampling points were plotted on a 200 feet to 1 inch scale map and transcribed electronically using a NUMONICS Model 224

Table 2. Examples of Typical Vertically-
Extrapolated Dye Concentrations

Date	Station	Depth (ft)	Concentration ($\mu\text{g/l}$) at Given Distance (ft) from Shore				
			25	50	75	100	125
8/03/83	32+75	0	(6.3)	(5.5)	(4.1)	(0)	
		1	6.3	5.3	4.3	0	
		2	6.4	5.0	4.5	0	
		3	6.5	5.1	(4.6)	(0)	
		4	(6.6)	5.3	3.5	0	
		5	6.3	(5.5)	2.3	0	
		6	6.0	5.2	(1.2)	0.1	
		7	5.6	4.8	1.0	(0.1)	
		8	(5.3)	4.5	0.9	0.1	
		9		(4.1)	0.7	0.1	
		10			0.5	0.1	
		11			0.4	0.1	
		12			(0.2)	0.1	
		13				0.1	
14				(0.1)			
9/13/83	51+00	0	(4.9)	(4.0)	(3.4)	(1.9)	(1.1)
		1	4.9	4.1	3.7	2.0	1.1
		2	4.9	4.2	(3.9)	(2.2)	1.1
		3	(4.9)	4.3	3.9	2.2	1.2
		4		(4.4)	3.8	2.3	1.2
		5		4.4	(3.8)	2.4	1.3
		6		4.5	3.8	(2.4)	1.3
		7		(4.5)	3.9	2.4	1.4
		8			4.0	2.5	1.5
		9			(4.1)	2.6	1.6
		10				2.7	1.7
		11				(2.7)	(1.7)

Note: Measured values are in parentheses

graphics calculator (digitizer) for transposition to University of Illinois computer facilities for conversion to the coordinate system.

U.S. Army Corps of Engineers cross-sectional depth soundings were plotted. Areas were determined using a manual planimeter.

All of the river dye concentrations (residuals) were expressed as a percent of the dye concentration in the simulated overflow discharge. The surface percentages for the six runs were plotted for use in developing percentage contour maps. The contours were done manually

using linear extrapolation. Primary weight was placed on proportionment in the lateral direction, while longitudinal proportionment was given secondary consideration.

RESULTS

Six successful runs were made at Cedar Street. Some conditions relative to these events are presented in table 3. Overall, 3600 samples were collected and analyzed, and the measured results were expanded by extrapolation to include over 12,000 data points. Unfortunately no extremes in river flows occurred during the field study, and the pool stage remained relatively constant throughout. This was not entirely desirable, but it did provide an opportunity to make comparisons between outfall types and variable sewer flows during relatively steady state river conditions. River flows in the range presented in table 3 are considered "normal" summer rates at Peoria.

Typical data sets for the surface and for water depths of 3 and 10 feet are presented in tables 4, 5, and 6, respectively. Note that the number of stations sampled is less with increasing depth. This is because the depth decreases downstream, as demonstrated by figure 17. The stations where the water depth is less than a sampling depth have been omitted in the tables. For example, in table 6 the results are given for the 10-foot water depth; therefore stations 46+00, 47+00, 48+00, 54+00 through 59+00, 62+00, and 68+00 have been omitted because

Table 3. Dates and Conditions Relative
to Successful Overflow Simulations

Date	Type	Sewer Conditions		River Conditions	
		Flow (gpm)	Dye Conc. (µg/l)	Pool Elev. (MSL)	Flow(cfs)
8/03	Combined	3200	220	440.3	7092
8/09	Combined	1600	549	440.2	7276
8/16	Storm	1600	549	440.0	6725
8/23	Storm	3200	284	440.3	8566
8/31	Storm	2400	369	440.6	8280
9/13	Combined	2400	378	440.1	7770

Table 4. Dye Concentrations ($\mu\text{g/l}$), 8/Q3/83, 0 ft

Sta	Distance from Right Bank							
	25	50	75	100	125	150	175	200
2975	3.7	0.0						
3025	76.9	23.5	.1	0.0				
3075	8.2	5.7	0.0	0.0				
3125	8.9	9.0	0.0	0.0				
3175	7.4	11.6	.6	0.0				
3275	6.3	5.5	4.1	0.0				
3325	6.0	5.6	.1	.1				
3400	5.0	6.0	4.6	.1				
3500	4.5	5.9	5.1	1.3				
3600	4.8	4.6	1.9	0.0				
3700		3.7	1.1	0.0				
3800		2.7	0.0	0.0				
3900		5.4	3.8	.6				
4000		1.6	1.0	1.4				
4100		1.0	1.3	1.4				
4200	.9	1.3	1.5	1.4				
4300	1.4	1.4	1.2	1.6				
4400	.7	.6	.8	1.2				
4500	1.3	1.3	1.5	.2				
4600	1.0	1.3	1.4	1.6				
4700	1.6	1.6	2.1	2.1				
4800	1.2	2.0	1.6	1.4				
4900	.6	.6	.6	.7				
5000	.8	.8	.9	1.0				
5100	.8	.8	.8	.8				
5200	.7	.7	.6	.7				
5300	.7	.7	.8	.9				
5400	.6	.7	.8	.9				
5500	.6	.8	.9	1.1				
5600	.6	.6	.7	1.5				
5700	.7	.6	.7	.8				
5800	.6	.8	.7	.8	1.0			
5900	.6	.6	.8	.8	1.0			
6000				.6	.6	.7	1.2	1.0
6100				.6	.6	.7	.6	.8
6200				.6	.6	.5	.7	.7
6300			.5	.6	.6	.5	.6	.5
6400			.5	.6	.6	.6	.6	.6
6600		.6		.6	.6	.6	.6	.5
6800		.7		.7	.5	.6	.5	.6
7000		.6		.7	.8	.6	.8	.7

Table 5. Dye Concentrations $\mu\text{g/l}$), 8/03/83, 3 ft

Sta	Distance from Right Bank							
	25	50	75	100	125	150	175	200
2975	2.2	0.0	0.0	0.0				
3025	51.0	0.0	0.0	0.0				
3075	7.9	0.0	0.0	0.0				
3125	8.9	6.3	6.4	0.0				
3175	8.0	9.6	.3	0.0				
3275	6.5	5.1	4.6	0.0				
3325	5.9	4.9	.1	.1				
3400	5.3	6.1	4.0	.1				
3500	4.6	5.9	2.5	.1				
3600	4.9	4.6	2.5	.2				
3700		2.8	2.1	0.0				
3800		.9	.1	.1				
3900		4.3	2.6	1.6				
4000		1.6	1.5	1.5				
4100		1.2	1.3	1.0				
4200	1.1	1.3	1.5	.9				
4300		1.3	1.3	1.7				
4400		.3	.3	1.2				
4500	1.0	1.3	1.1	.1				
4600	.8	.7	1.3	1.5				
4700	1.3	1.4	1.7	2.1				
4800	1.0	1.2	1.1	.9				
4900	.4	.5	.3	.5				
5000	.6	.8	.8	.7				
5100	.7	.9	.8	.9				
5200	.6	.4	.5	.6				
5300	.6	.7	.8	.6				
5400	.7	.8	.8	.9				
5500	.7	.7	.8	.9				
5600	.7	.7	.6	.8				
5700		.7	.8	.8				
5800		.7	.8	.9	1.0			
5900				.8	.9			
6000						.7	.9	.8
6100						.6	.5	.6
6200					.6	.6	.6	.7
6300				.6	.6	.6	.6	.5
6400				.6	.6	.5	.4	.6
6600				.5	.6	.6	.5	.6
6800				.6	.5	.5	.5	.4
7000				.7	.5	.6	.5	.5

Table 6. Dye Concentrations ($\mu\text{g}/\text{l}$), 8/03/83, 10 ft

Sta	Distance from Right Bank							
	25	50	75	100	125	150	175	200
2975			0.0	0.0				
3025	16.1	.3	0.0	0.0				
3075			0.0	0.0				
3125			0.0	0.0				
3175		8.6	.4	0.0				
3275			.5	.1				
3325		2.5	.1	.1				
3400		4.7	.9	.1				
3500			.9	0.0				
3600			1.0	0.0				
3700		1.4	1 . 3	. 1				
3800		.1	.1	0.0				
3900		.6	.2	0.0				
4000			.5	.7				
4100		.3	.3	.1				
4200			.1	.1				
4300			.8	.7				
4400			.4	.5				
4500		1.2	.4	.2				
4900				.1				
5000			.6	.6				
5100			.5	.6				
5200			.3	.4				
5300			.2	0.0				
6000								.6
6100								.3
6300								.2
6400					.4	0.0	.6	.4
6600							.5	.4
7000								.4

the water depths at all the sampling verticals at these locations are less than 10 feet. The blank spaces between 36+00 and 42+00 appearing on all six data sets for the water surface represent an absence of samples due to docked barges (see figure 12a). The blank spaces below 59+00 (see table 4) essentially trace the outer edge of a slightly exposed sand bar (see figure 12b). In all, 87 tabular data sets, similar to those given in tables 4, 5, and 6 but given in terms of percentages, were developed and are presented in Appendix D.

The percentage data presented in Appendix D were derived by dividing the observed river dye concentration by the appropriate sewer dye concentrations presented in table 3 and multiplying by 100. This allowed relative comparisons to be made between runs. Table 7 presents a tabular comparison of percentages of residual dye concentrations at the surface and 3-foot depth at 50 feet from shore.

Some casual observations relative to temporal and spatial differences can be ascertained from an examination of the data presented in table 7. For the relatively low simulated overflow rates achieved during the study, the dye quickly dissipated; dye percentages were less than 2 percent about 1000 feet below the outfall. At only 150 feet below the outfall, they were less than 5.5 percent. Although dilution and dispersion rapidly reduced the downstream concentrations to low levels in all cases, distinct differences between some runs are evident. Some of these differences can be attributed to the fact that ADM withdraws a very large amount of cooling water at station 39+00 and returns it to the river at station 41+00. For the first 20 days of

Table 7. River Dye Concentrations as a Percentage of Sewer Concentrations 50 Feet from Shore

River cfs - Sewer gpm -	Surface (%)						3-foot Deep (%)					
	Part Submerged			Overland			Part Submerged			Overland		
	7276	7770	7092	6725	8280	8566	7276	7770	7092	6725	8280	8566
27+75 *	0	0	1.7	0.7	0	0	0	3.6	1.0	3.6	0	0
30+25 *	10.4	11.1	34.9	14.3	22.9	1.9	11.0	14.0	23.2	10.9	15.2	1.3
30+75	1.1	0	2.6	5.1	0	0	0.9	2.0	0	2.4	-	0
31+25	0.5	0.1	4.1	0.9	5.5	0.1	6.0	1.2	2.9	5.6	2.0	0.2
31+75	4.6	4.2	5.3	0.4	3.6	0.1	2.4	1.0	4.4	3.2	3.7	0.1
32+25	-	0.7	-	-	2.1	1.6	-	1.2	-	-	0.1	1.8
32+75	0.1	-	2.5	0.7	-	-	0.2	-	2.3	2.9	-	-
33+00	-	0.1	-	-	1.6	0.6	-	0.1	-	-	0.8	0.4
33+25	0.5	-	2.5	1.1	-	-	0.5	-	2.2	2.3	-	-
34+00	0.7	4.0	2.7	2.0	0.3	0.5	3.4	2.9	2.8	2.3	0.2	2.6
35+00	1.5	2.4	2.7	2.2	3.7	0.3	0.6	0.8	2.7	2.4	2.8	0.3
36+00	0.3	2.5	2.1	1.9	0.8	1.4	0.1	2.0	2.1	1.6	1.4	1.8
37+00	1.5	-	1.7	0.6	-	-	1.5	-	1.3	1.0	-	-
38+00	1.5	-	1.2	0.9	-	-	1.3	-	0.4	1.2	-	-
39+00	0.8	0.6	2.5	0.6	0.2	1.6	0.9	0.6	2.0	0.6	1.6	0.5
40+00	0.5	-	0.7	-	-	-	0.4	-	0.7	-	-	-
41+00	0.7	-	0.5	-	-	-	0.6	-	0.5	-	-	-
42+00	0.8	1.3	0.6	0.3	1.1	1.4	0.8	1.6	0.6	0.2	0.6	1.1
43+00	0.6	1.3	0.6	0.2	1.3	0.7	0.4	1.3	0.6	0.1	1.4	0.8
44+00	0.1	1.4	0.3	0.3	1.6	1.5	0.1	1.5	0.1	0.2	1.1	1.3
45+00	1.0	0.7	0.6	0.3	1.5	1.2	0.7	0.8	0.6	0.2	1.4	1.0
46+00	0.4	1.3	0.6	0.3	1.4	0.6	0.3	1.3	0.3	0.2	1.4	0.7
47+00	0.7	1.2	0.7	0.3	1.4	1.2	0.4	1.2	0.6	0.2	1.3	1.2
48+00	0.4	1.3	0.9	0.3	1.6	0.8	0.2	1.3	0.5	0.3	1.5	1.0
49+00	0.3	1.1	0.3	0.2	1.5	0.7	0.1	0.9	0.2	0.2	1.5	0.7
50+00	0.3	1.5	0.4	0.3	1.4	0.8	0.1	1.5	0.4	0.2	1.3	0.9
51+00	0.6	1.1	0.4	0.2	1.4	0.1	0.5	1.1	0.4	0.2	1.3	0.1
52+00	0.5	1.2	0.3	0.4	1.3	1.0	0.3	1.1	0.2	0.3	1.2	1.0
53+00	0.2	1.2	0.3	0.3	1.4	0.7	0.2	1.2	0.3	0.5	1.4	0.7
54+00	0.3	1.3	0.3	0.3	1.5	0.6	0.2	1.3	0.4	0.3	1.4	0.6
55+00	0.3	1.1	0.4	0.3	1.4	0.6	0.3	1.1	0.3	0.3	1.3	0.5
56+00	0.3	0.8	0.3	0.3	1.4	0.5	0.2	0.7	0.3	0.2	1.3	0.5
57+00	0.2	1.3	0.3	0.3	1.3	1.0	0.2	1.2	0.3	0.2	1.3	1.0
58+00	0.3	1.2	0.4	0.3	1.3	1.0	0.2	1.2	0.3	x	0.3	x
59+00	0.3	1.1	0.3	0.4	1.3	1.0	x	x	x	x	1.1	x
60+00	0.3	1.2	0.3	0.3	1.1	1.0	x	x	x	0.3	x	x
61+00	0.3	1.1	0.3	0.4	1.2	0.6	x	x	x	x	x	x
62+00	0.2	0.9	0.3	0.2	1.1	0.4	0.3	0.9	0.3	x	1.0	0.3
63+00	0.2	0.6	0.3	0.2	0.9	0.2	0.1	0.6	0.3	x	1.0	0.2
64+00	0.1	0.8	0.3	0.2	0.9	0.2	x	0.6	0.3	0.2	0.9	0.1
66+00	0.1	0.7	0.3	0.2	1.0	0.6	0.1	0.6	0.2	x	1.0	0.5
68+00	0.1	0.7	0.3	0.2	1.1	0.5	0.1	0.5	0.3	0.1	0.6	x
70+00	0.1	0.6	0.3	0.1	1.0	0.7	0.1	x	0.3	0.1	0.9	x

* 25 feet from shore at these stations

- No sample taken

x water depth less than 3 feet

Shaded columns indicate no ADM cooling water discharge

August, the average withdrawal rate was 21.7 mgd, and the average spent cooling water discharge rate was 29.7 mgd; 8 mgd of the total discharge originated from ground water sources. After August 20, ADM ceased grain processing operations, and the discharge was reduced to a negligible 0.07 mgd.

Note that for the three runs made after August 20 (shaded columns in table 7), relative concentrations were generally three to four times greater in the lower third of the sampling area. The fact that these last three runs were made at the same time as the three highest river flows may have contributed to this phenomenon. Some differences do appear to occur in the dispersion patterns in the immediate sewer discharge area (station 30+25). The highest residual concentration occurred for the 3200-gpm partially submerged discharge, while conversely the lowest occurred for the 3200-gpm overland discharge. The partially submerged discharge tended to produce higher relative concentrations 25 feet out with increasing sewer discharge rates. For some unknown reason, the 3200-gpm overland flow did not produce surface 25-foot concentrations in the immediate area of the outfall that were nearly as significant as those produced by the other runs. For this run the dye tended to submarine somewhat; a relative percentage of 10.6 was observed 12 feet deep at 25 feet out, while a 21.2 relative percentage was observed 2 feet deep at 50 feet out. Evidently the dye went deep at 25 feet and started to resurface in an outward direction.

Table 8 has a format similar to that of table 7. However, it shows the lateral distance at a given station at which the maximum dye

Table 8. Distance from Shore the Maximum Dye Concentration Was Observed

River cfs - Sewer gpm -	Surface - Distance in Feet						3-feet Deep - Distance in Feet					
	Part Submerged			Overland			Part Submerged			Overland		
	7276 1600	7770 2400	7092 3200	6725 1600	6820 2400	8566 3200	7276 1600	7770 2400	7092 3200	6725 1600	8280 2400	8566 3200
29+75			25	50				25	25			
30+25	25	25	25	25	25	25	25	25	25	25	25	50
30+75	25	25	25	25	25	25	25	25	25	50	25	25
31+25	25	25	50	25	25	25	50	25	25	50	25	25
31+75	25	25	50	25	25	25	25	25	50	50	25	25
32+25	-	25		-	25	25	-	25	-	-	25	25
32+75	25	-	25	25	-	-	25	-	25	25	-	-
33+00	-	25	-	-	25	25	-	25	-	-	25	25
33+25	25	-	25	25	-	-	25	-	25	25	-	-
34+00	25	50	50	25	25	25	25	25	50	50	25	25
35+00	25	25	50	50	25	25	75	25	50	50	50	25
36+00	25	50	25	50	25	25	100*	100*	25	25	25	25
37+00	50	75	50	50	-	-	50	75	50	75	-	-
38+00	50	75	50	75	-	75	50	75	50	100*	-	75
39+00	50	50	50	100*	25	25	50	50	50	100*	25	25
40+00	50	75	50	100*	75	75	50	75	100*	100*	75	75
41+00	100*	75	100*	75	75	75	50	75	75	75	75	75
42+00	25	50	75	100*	25	25	50	50	75	75	25	25
43+00	25	25	100*	100*	50	25	25	25	100*	100*	50	25
44+00	25	25	100*	100*	50	50	100*	50	100*	75	50	50
45+00	50	25	75	75	100	50	50	25	50	100*	25	50
46+00	75	50	100*	100*	25	25	75	50	100*	100*	25	75
47+00	75	50	100*	100*	25	50	50	50	100*	100*	75	50
48+00	75	50	50	100*	50	25	75	50	75	100*	50	50
49+00	100*	25	100*	25	50	25	25	25	100*	100*	50	25
50+00	100*	50	100*	50	75	25	100*	50	75	100*	100	25
51+00	100*	25	100*	25	125*	75	50	25	100*	75	50	75
52+00	100*	25	100*	100*	25	50	50	25	100*	75	25	50
53+00	25	25	100*	100*	25	100	75	50	75	75	25	75
54+00	100*	75	100*	100*	50	25	75	50	100*	75	50	75
55+00	100*	75	100*	100*	50	50	50	75	100*	100*	75	50
56+00	50	75	100*	100*	50	25	75	75	100*	100*	50	100
57+00	75	100	100*	100*	50	100	75	75	100*	75	50	100
58+00	50	100	125*	125*	75	75	125*	100	125*	125*	75	75
59+00	75	100	125*	50	100	100	125*	100	125*	125*	100	150
60+00	125	125	200*	200*	150	125	175	175	200*	200*	150	175
61+00	200*	175	200*	125	100	175	200*	175	200*	200*	175	175
62+00	200*	175	200*	200*	150	200*	200*	150	200*	200*	150	200*
63+00	200*	175	175	200*	175	200*	200*	125	175	200*	175	200*
64+00	200*	200	200*	200*	175	125	200*	200*	200*	125	200*	150
66+00	200*	50	175	200*	125	50	200*	175	200*	200*	150	100
68+00	200*	175	200*	175	175	125	200*	150	100	175	150	125
70+00	200*	50	175	200*	175	50	200*	125	150	175	125	200*

Underlined values indicate interlimit distance sampled

* indicates outlimit distance sampled

- indicates no sample taken

Shaded columns indicate no ADM cooling water discharge

concentration was observed. The most striking information evident in the table is that on the three ADM cooling water discharge days the maximum dye concentrations as a whole are located significantly farther from shore. In the lower half of the sampling reach, the maximum values were generally at the outer limits of the sampling points for these three days, whereas on the three no-cooling water discharge days the maximum values generally fell well within the outer sampling limits. This fact, coupled with the information discussed in conjunction with table 7, clearly shows that the ADM cooling water discharge has a major impact on the mixing zone configuration and dispersion pattern below the cooling water intake.

The 3-foot depth values are listed in table 8 for comparative purposes. Any differences between these values and the surface ones could represent wind effects on the surface distribution. Overall no differences are readily discernible. Nevertheless, the maximum concentration positions were not always consistent between the two depths. This was particularly evident for the partially submerged and overland 1600-gpm runs. For example, the partially submerged 1600-gpm run produced maximum surface concentrations significantly farther out than the maximums produced at the 3-foot level between 49+00 and 55+00, while between 56+00 and 60+00, the reverse was true: the 3-foot maximum extended farther out than the surface maximums. During this run, a southwest wind persisted at an estimated velocity of 10 mph.

Figures 18 through 23 diagrammatically illustrate the surface dye distribution patterns for the six runs. The contours are representative

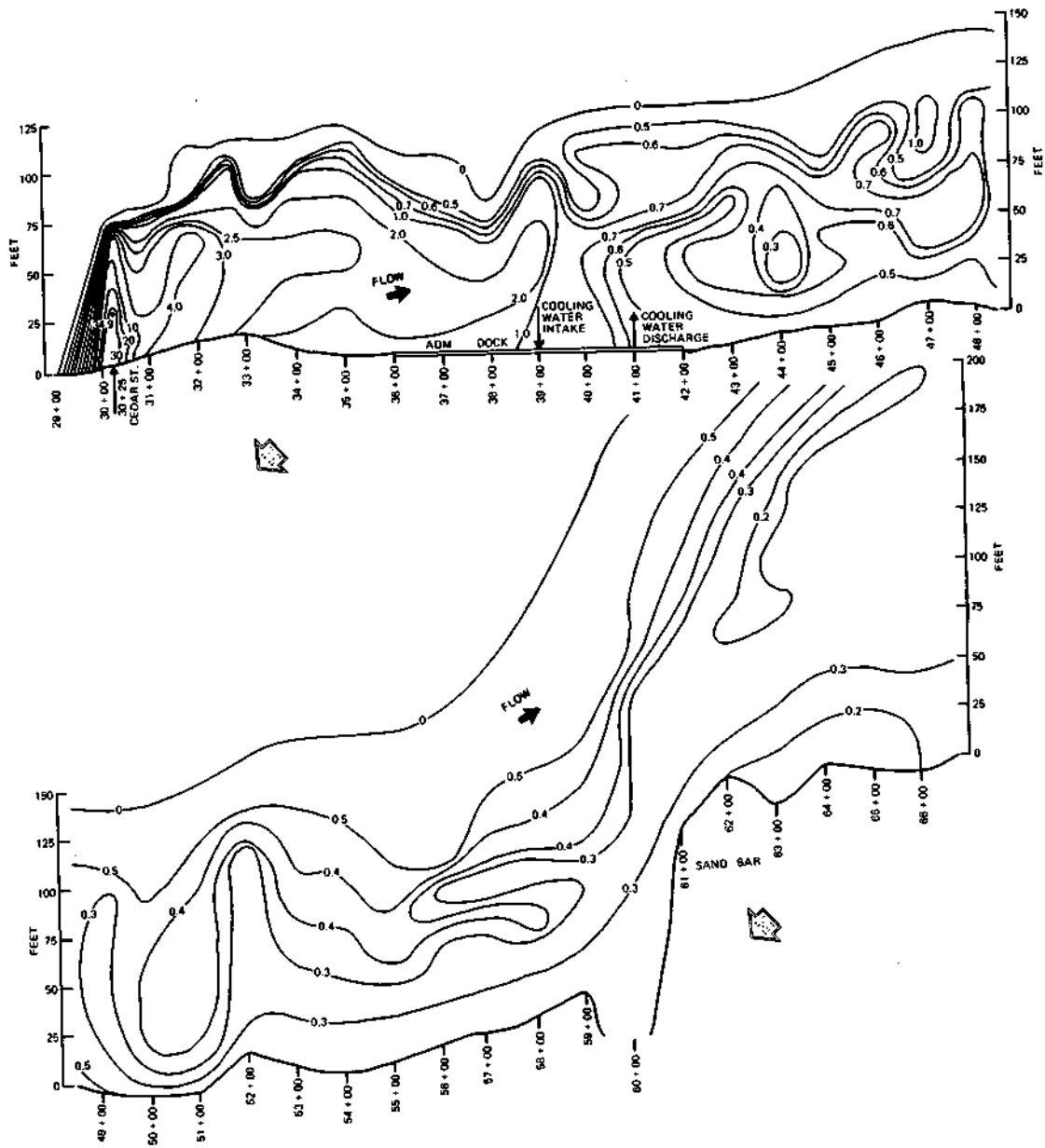

Figure 18. August 3, 1983 surface percentage contours, partially submerged, 3200 gpm

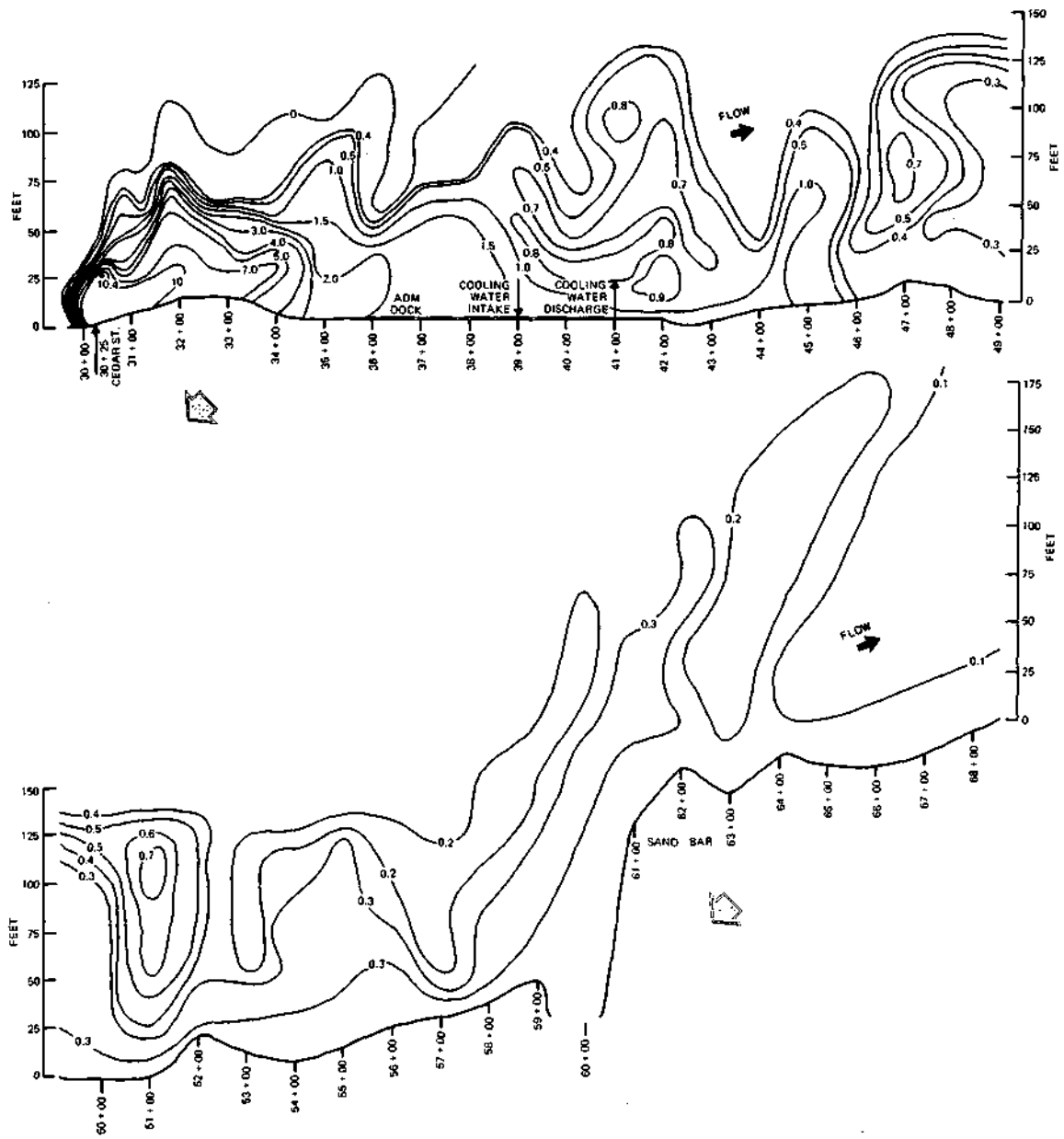

Figure 19. August 9, 1983 surface percentage contours, partially submerged, 1600 gpm

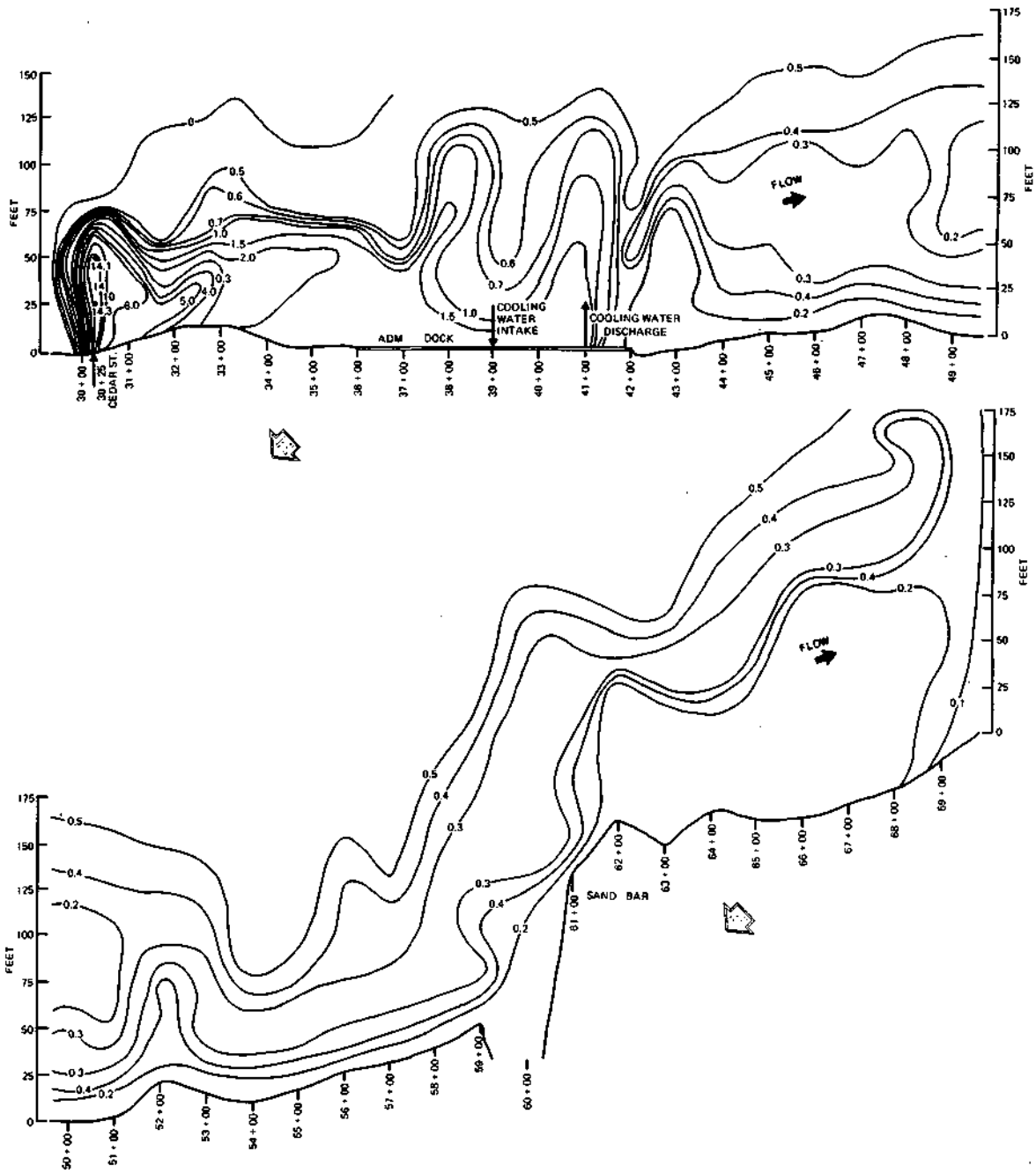

Figure 20. August 16, 1983 surface percentage contours, overbank, 1600 gpm

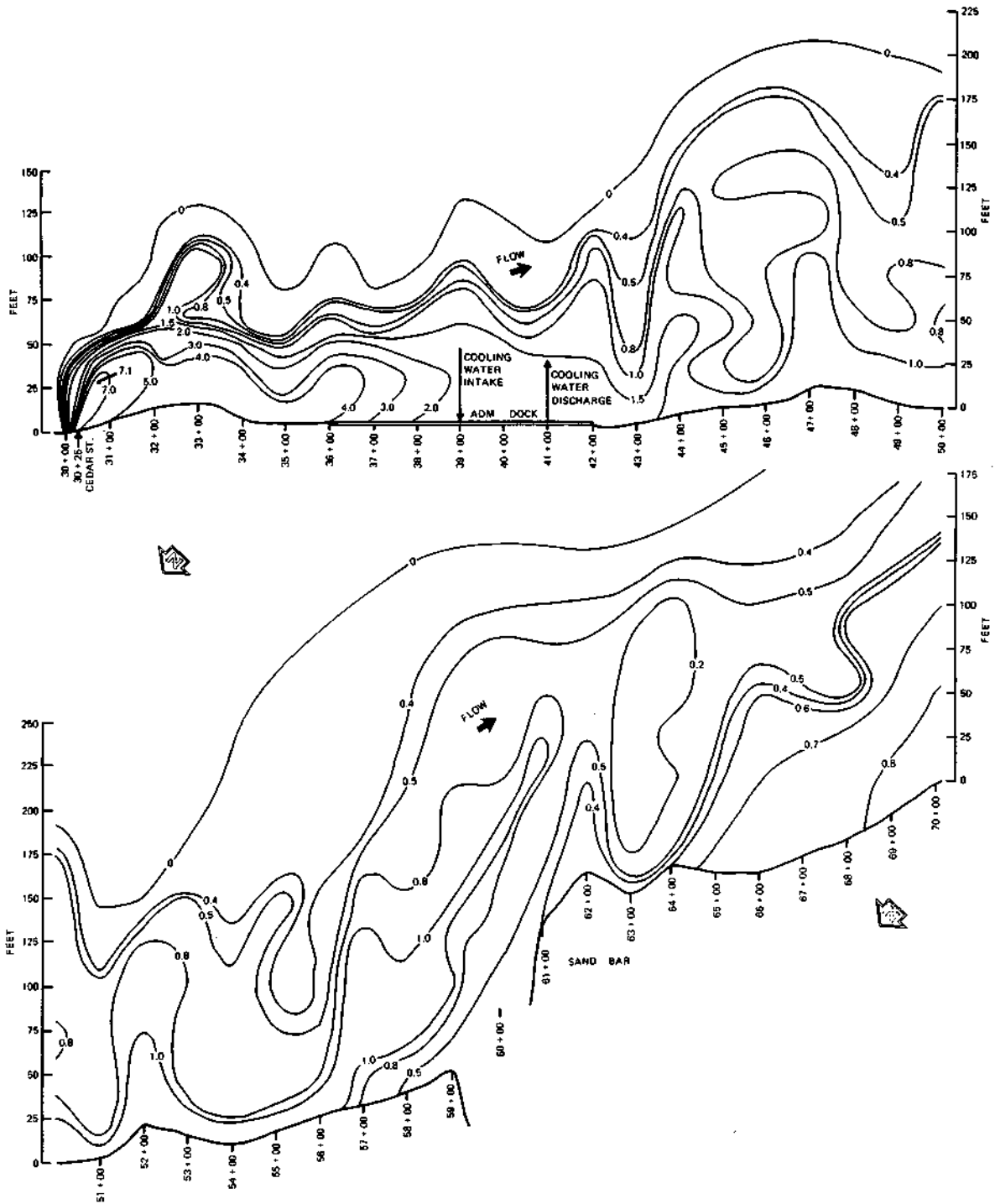

Figure 21. August 23, 1983 surface percentage contours, overbank, 3200 gpm

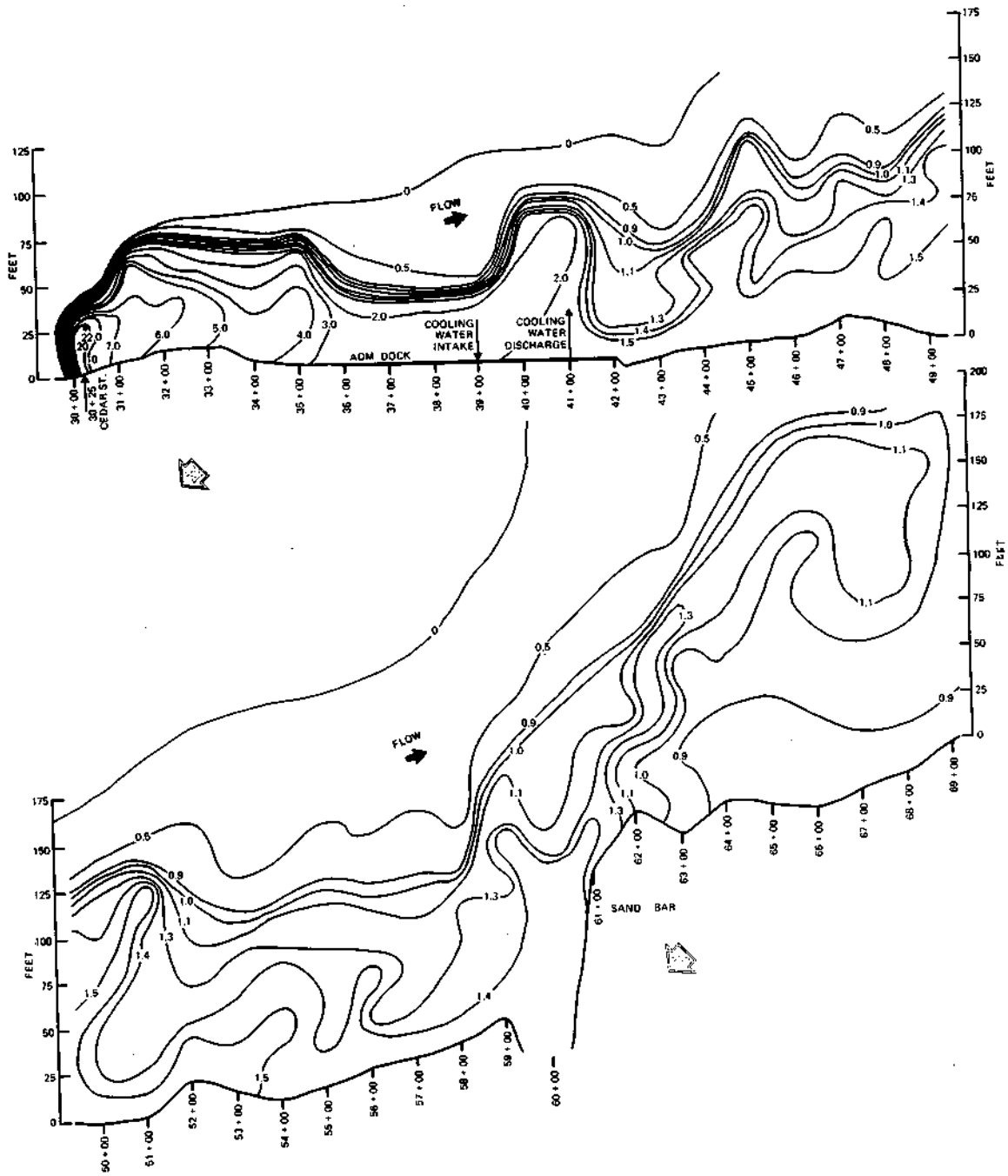

Figure 22. August 31, 1983 surface percentage contours, overbank, 2400 gpm

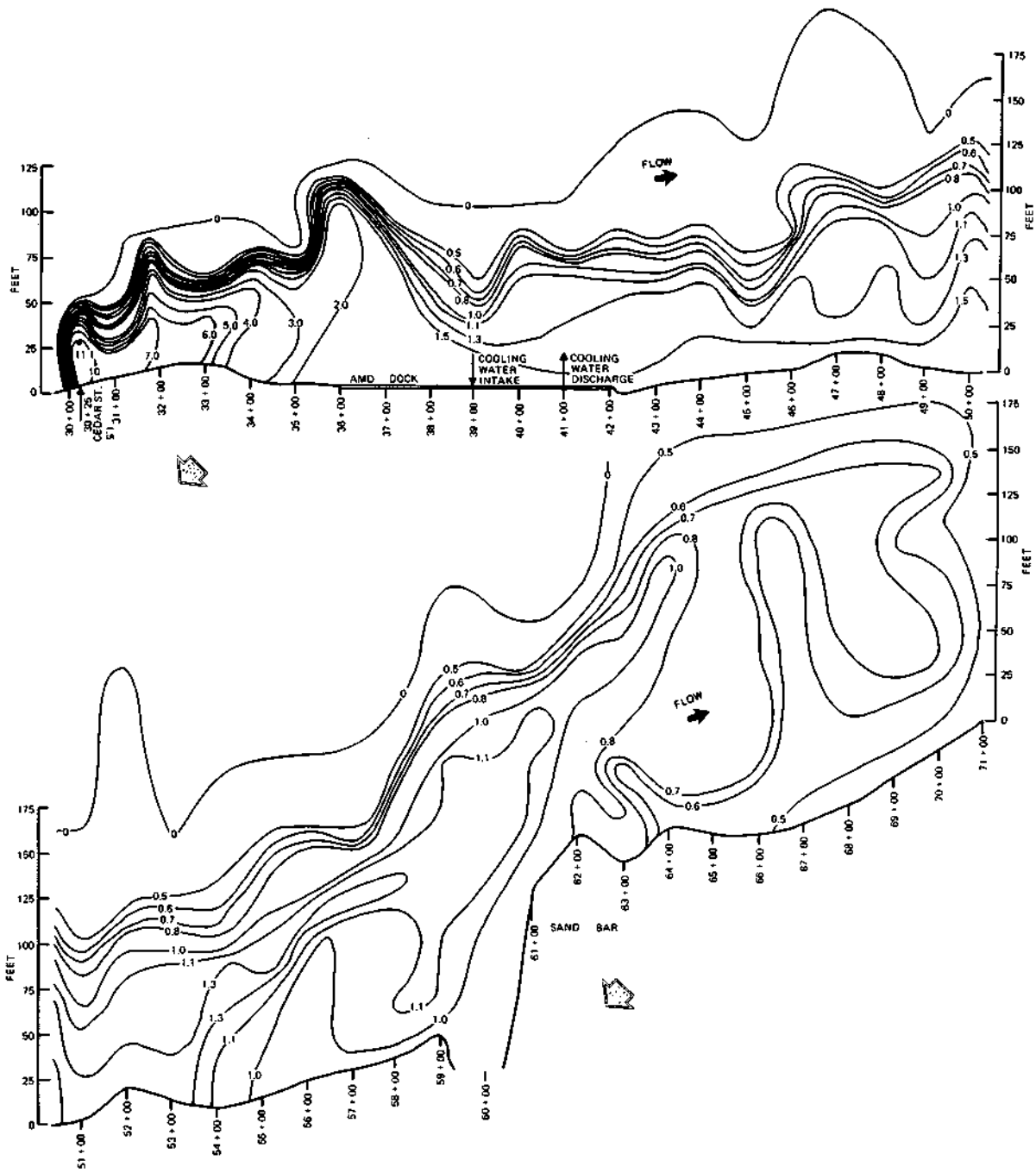

Figure 23. September 13, 1983 surface percentage contours, partially submerged, 2400 gpm

of percentages of the original sewer discharge dye concentration. An examination of these figures reveals that each run produced its own "fingerprint." Common characteristics or traits among each are not readily apparent. Close inspection will, however, reveal some limited conformity within two specific groupings of runs. The first three runs, represented by figures 18 through 20, were conducted during the period ADM was withdrawing and discharging cooling water at 39+00 and 41+00, respectively. They all exhibited some common characteristics. Noteworthy is the fact that the cooling water recycling created a very noticeable discontinuity in the dye distribution pattern below 39+00; islands or random pockets of residual dye concentrations were created. In addition, the contours "sagged" noticeably toward the shore in the area of the ADM loading docks instead of displaying continual outward lateral dispersion. The recycling of cooling water appeared to blunt the downstream movement of the dye.

During the last three runs (figures 21-23), when cooling water recycling was absent, the dye contours displayed good continuity in the area of the ADM loading docks and throughout the affected stream downstream of the docks. Significantly higher concentrations were observed in the lower sampling reaches compared to the first three runs. The last three runs did share one common trait with the first three runs: outward lateral dispersion was disrupted in the loading dock area. The lack of lateral dispersion was not as pronounced as that observed during the cooling water recycling dates. Abrupt contour discontinuities did not develop. The inward sag was more smooth and

orderly, providing a dented but unbroken link with all the downstream contours. Color slides taken during the runs clearly show the inward sag of the dye in the docking area. A large sudden increase in depth appears to be the cause of this phenomenon. An examination of figure 17 reveals that in the area of 36+00 the depth abruptly increases by 5 or 6 feet and then abruptly decreases by about 7 feet at 43+00 immediately below the docks. The reversal in the dispersion pattern, the great variability in depth, and the cooling water intake-discharge interference make a theoretical assessment and mathematical modeling of the mixing zone in the area below 36+00 almost impossible.

The maximum surface percentages in the outfall area are noted in figures 18 through 23. A logical relationship appears to exist between the ratio of sewer and river discharge rates and the residual concentrations of the dye 25 feet from shore. Figure 24 shows two sets of curves fit to a parabolic model. The percentages represent the maximum values observed anywhere on the vertical 25 feet from shore. Only for three of the six runs did the maximum occur at the surface; the others occurred at 2-, 7-, and 12-foot depths. The concave curve represents the model fitted to the six actual observations. The fit is very good. The estimates are reasonable within the limits of the observed data; however, predictions for high discharge ratios outside the maximum of 0.001 observed during the study are poor. Realistically, the percentage for a sewer flow to river flow ratio of 0.1 should approach 100 percent. Using a value set composed of 0.1 and 92 percent in combination with the six observed value sets, a more inclusive model

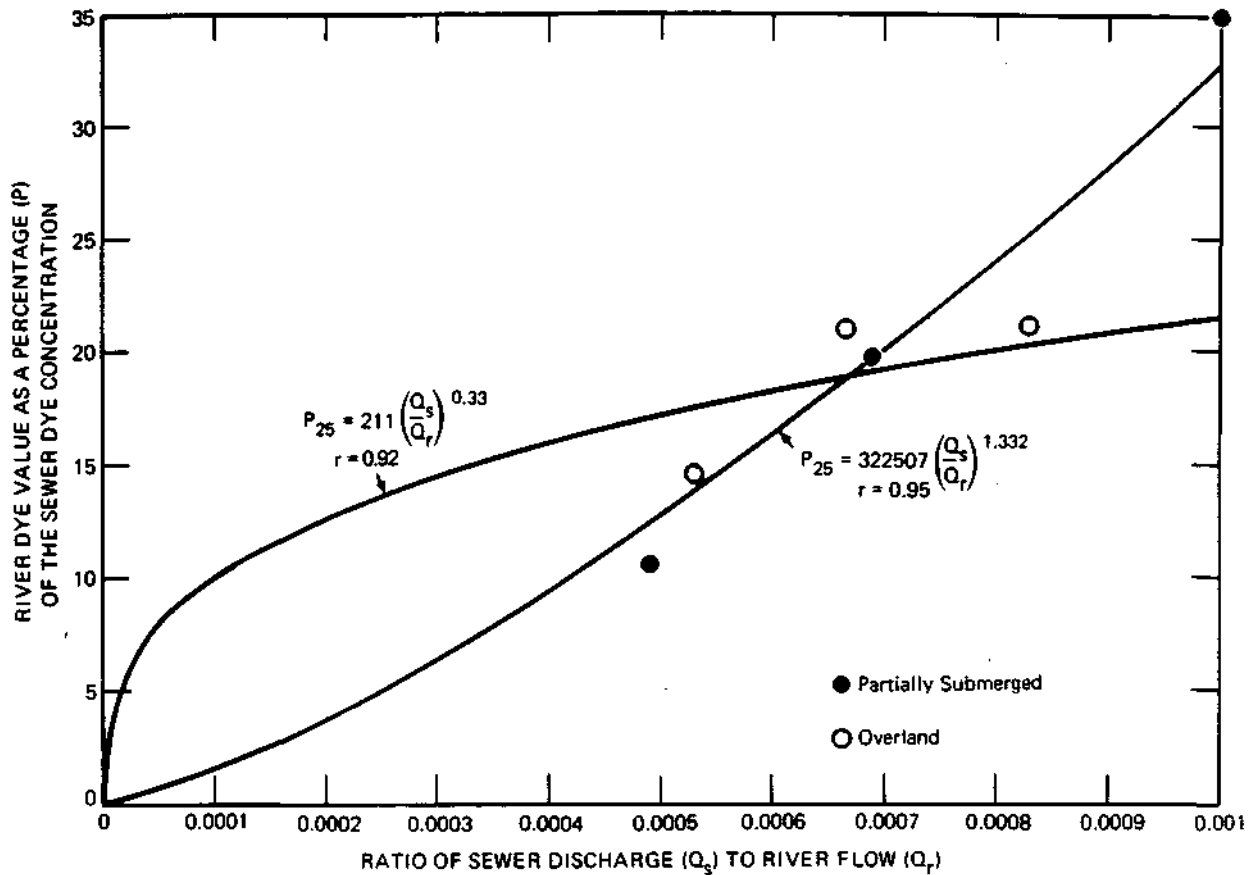

Figure 24. Maximum dye percentage composition in river at Cedar Street outfall (station 30+25) 25 feet from outfall

was derived. It is represented by the convex curve shown in figure 24 and is mathematically described by:

$$P_{25} = 211 (Q_s/Q_r)^{0.33} \quad (4)$$

where p_{25} = the river dye concentration 25 feet from shore, divided by the sewer dye concentration, multiplied by 100 (a percentage); Q_s = the sewer flow (cfs); and Q_r = the river flow (cfs). The correlation with observed points remains high; therefore equation 4 should produce reasonable estimates of maximum values at 25 feet from shore over a wide range and combinations of sewer and river flow conditions. For example

if a 1.56 inch/hour storm occurs when the river flow is 6,000 cfs, Q_s/Q_r would equal 458/6000 or 0.076; following from equation 4, P_{25} equals 90.1 percent. Similarly for a much smaller storm of 0.37 inch/hour when Q equals 6000, P_{25} equals 46.7 percent.

Table 9 lists some data for the three 1982 CSO sampling runs at Cedar Street (Staff of Water Quality Section, Illinois State Water Survey, 1983) and the estimated effects on the river 25 feet from shore. Noteworthy is the fact that although the sewer overflow rates on August 24 were much greater than on September 17, the effects of both overflows on river water quality in the immediate area of the outfall were about the same.

Table 9. P_{25} Estimates for 1982 Cedar Street Combined Sewer Overflow Sampling Data

Date	River Flow (cfs)	10-minute sewer flow (cfs)	Q_s/Q_r	Observed Sewer Concentrations (mg/l)			Estimated River Concentration (P_{25})		
				NH ₃	Pb	Sus. solids	NH ₃	Pb	Sus. solids
6/28/82	10,335	17.6	.0017	0.9	0.28	499	0.2	0.06	128
		9.6	.0009	0.8	0.22	333	0.2	0.05	70
		2.6	.0003	0.8	0.19	304	0.1	0.03	42
8/24/82	8,175	5.4	.0007	3.6	0.68	715	0.7	0.13	135
		131.3	.0161	1.0	0.58	831	0.5	0.31	449
		115.9	.0142	0.1	0.30	476	0.1	0.15	247
		121.0	.0148	0.1	0.24	402	0.1	0.13	211
		166.0	.0203	0.1	0.22	325	0.1	0.30	190
9/17/82	6,600	316.4	.0387	0.1	0.14	281	0.1	0.10	203
		16.1	.0024	3.4	0.70	1100	1.0	0.20	318
		22.5	.0034	3.1	0.60	850	1.0	0.20	276
		26.7	.0040	2.0	0.58	633	0.7	0.20	217
		24.1	.0037	1.4	0.44	445	0.5	0.15	147
		14.9	.0023	1.2	0.36	382	0.3	0.10	108
		6.8	.0010	1.3	0.30	355	0.3	0.07	77
3.8	.0006	1.5	0.11	278	0.3	0.02	50		
3.0	.0005	1.5	0.08	183	0.2	0.01	30		

DISCUSSION

An attempt will be made in this section to provide some insight into what factors must be considered in developing or defining a mixing zone for overflow conditions similar to those simulated at Cedar Street.

Mere visual examination of figures 18 through 23 reveals that a mixing zone at a given outfall cannot be viewed as a well-defined fixed entity. It should be viewed as variable, with the variability dictated by outfall types (degree of submergence, free fall, overbank) in conjunction with sewer flows and river discharge conditions. Lateral and longitudinal projections of specific percentage contour elements appear to be the most logical approach for establishing limits for a mixing zone.

The relationship between the sewer discharges and the river flows is considered here to be the foremost factor. Hence, the dimensionless ratio, Q_s/Q_r , as defined in equation 4, was used to develop relationships for predicting the extent of the sewer discharge penetration into the river for any combination of sewer and river hydraulic conditions. Figures 25a and 25b show the plots of the three runs for both outfall types. The partially submerged outfall data (figure 25a) show that increasing hydraulic ratios (Q_s/Q_r) are directly correlated with the sewer discharge penetration into the river. While data for a wide range of river flows are limited, rational expectation would be that high sewer flows during low river flows would penetrate farther into the river than would low sewer flows during high river flows. In line with this reasoning constant penetration would be

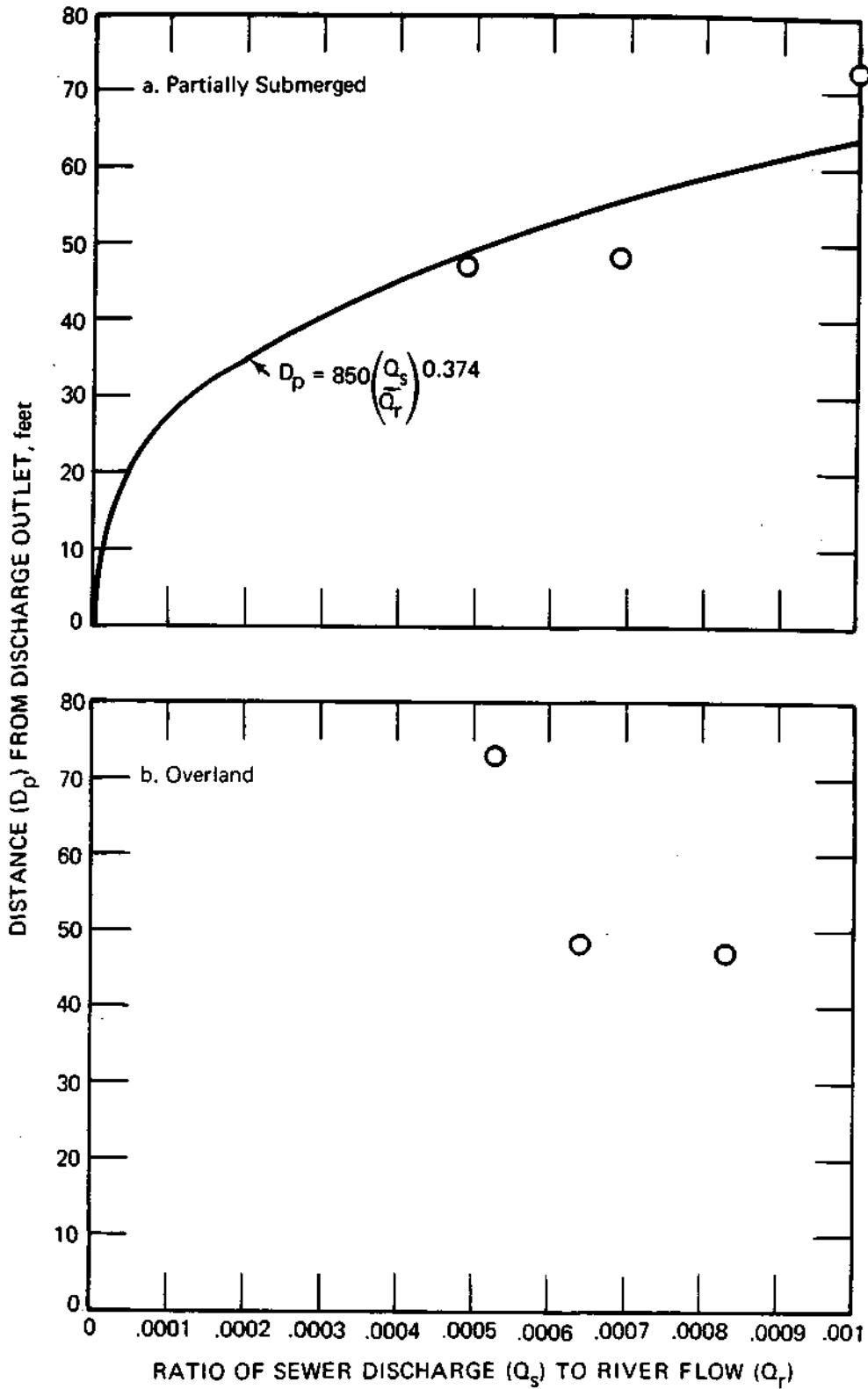

Figure 25. Sewer discharge projection into river at station 30+25 to 1 percent of the sewer composition (partially submerged and overland)

expected for a constant hydraulic ratio regardless of the absolute sewer and river discharge rates.

The penetration distance for the overbank discharge data (figure 25b) does not appear to be correlated with the hydraulic ratio. There is some rationale for this observation. It is to be expected that energy will be dissipated by the land surface before the sewer overflow reaches the river, thereby preventing detectable differences from being measured over the low range of sewer and river flows encountered during this study. Detectable differences could probably be ascertained and correlations made for considerably higher hydraulic ratio situations used in conjunction with the three points presented in figure 25b.

A parabolic model was used to describe the relationship between the penetration distance from the banks into the river and the hydraulic ratio for specific percentage contour points. The 1-percent curve and respective data points are presented in figure 25a. Similar curves were generated for 2, 3, 4, 5, and 10 percent. This produced a family of essentially parallel curves when plotted on log-log scales as shown by figures 26a, 26b, and 26c. The generalized model used to generate these curves is expressed as:

$$D_p = a(Q_s/Q_r)^b \quad (5)$$

where D_p = the penetration distance into the river (feet) for a specified percentage (p), Q_s and Q_r = the sewer flow and river flows, respectively, and "a" and "b" are coefficients derived using nonlinear regression techniques. Table 10 lists the "a" and "b" values associated with the various percentages examined. Also listed in the table is a

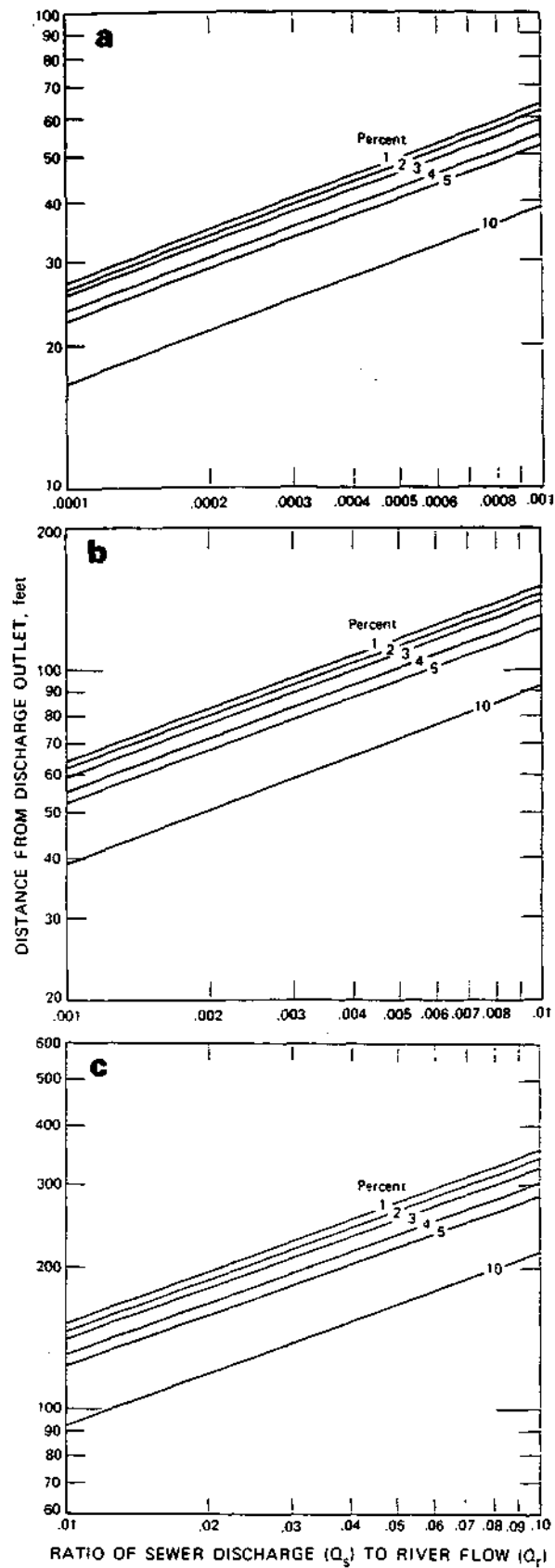

Figure 26. Lateral penetration of stated residual sewer flow into the Illinois River

Table 10. Parabolic Model Coefficients and Distances to Selected Percentage Points at Station 30+25

Percentages	Parabola Coefficients		Distances in Feet for Sewer to River Discharge Ratios (Q_s/Q_r) of Equation				Numbers
	a	b	.0001	.001	.01	.1	
1	850	0.374	27.1	64.2	151.9	359.3	(5)
2	805	0.371	26.4	62.1	145.8	342.6	(6)
3	772	0.370	25.6	59.9	140.5	329.3	(7)
4	722	0.371	23.7	55.7	130.8	307.3	(8)
5	668	0.367	22.7	52.9	123.2	286.9	(9)
10	515	0.372	16.7	39.4	92.9	218.7	(10)

matrix of predicted distances for specified percentages and hydraulic ratios.

These curves provide a basis by which the lateral limit of the mixing zone can be defined. For instance the establishment of an outer limit at the 10 percent level would mean that any water quality parameter that exceeds the stream water quality standard at this point or beyond would be in violation of the law. A practical example based on observed data will serve to illustrate this concept. The maximum ammonia concentration observed in the Cedar Street overflow during the September 17, 1982 sampling run was 3.4 mg/l (see table 9); the river pH was 8.0 and the temperature was 21 C. According to Section 302.212 of the Pollution Control Board Rules and Regulations, the maximum permissible stream ammonia concentration would be approximately 1.5 mg/l. Using equation 10 in table 10 or figure 26 curves, a concentration of 0.34 mg/l could be expected at a point approximately 54.6 feet from the outfall ($Q_s/Q_r = 0.0034$ as given in table 9). This value of 0.34 mg/l is well within the stream standards. Actually the combined sewer effluent ammonia concentration would need to exceed 15

mg/1 to cause a violation. Relative to this, Darst Street provided the highest ammonia concentration (12.5 mg/1) of any sewer sampled during the three 1982 CSO sampling runs during a small overflow rate of 1.5 cfs on September 17, 1982. If Darst had been a partially submerged outfall on the river bank, the 10 percent level of acceptance would have fallen 22.7 feet from the outfall.

An incongruity appears in this overall approach in that, for a given overflow rate, the allowable projection from shore increases with decreasing river flows. This, however, is probably not as significant as it appears since extremely high overflow rates are associated with much lower pollutant concentrations. High pollutant concentrations are associated more with low "first flush" overflow rates which often fall within the range of flows used to simulate overflows for this study. The data contained in table 9 illustrate this point. The 10-minute initial overflow rate of 5.4 cfs on August 24, 1982 at Cedar Street produced an ammonia concentration of 3.6 mg/1, whereas 50 minutes later the overflow rate of 316.4 cfs produced an ammonia concentration less than 0.1 mg/1. Most mixing zone sampling, to be significant, will have to be "first flush" discharge oriented. However, a direct approach could be taken to compensate for this incongruity by setting up a graduated percent scale inversely related to hydraulic ratio values. That is, for a given sewer overflow rate, a 10 percent concentration projection point could be arbitrarily set for relatively low river flows, whereas during higher river flows a 5 percent projection point could be used.

Dispersion and mixing in the downstream direction, as previously discussed, were greatly influenced by the withdrawal and return of cooling water between 39+00 and 41+00. The data in table 11 clearly show this influence. During the first three dates, when cooling water recycling was in effect, the average downstream distance to the 1-percent contour was 1182 feet, whereas for the last three dates in the absence of cooling water recycling, the average was 3503 feet. Even above the influence of the ADM docking facilities (600 feet below the outfall), the surface contour patterns were inconsistent. The 10-percent line varied from only 10 feet below the outfall up to 185 feet. A comparison of figures 18 through 23 will clearly show the diversity in downstream mixing patterns which occurred during this study. For this reason, the functional relationship describing the outward projection of the sewer discharge should be used for limiting allowable mixing for partially submerged outfalls.

Table 11. Longitudinal Distances to Specified Contour Line Percentages

Date	Maximum Distance in Feet to Percentage Contour of					
	1	2	3	4	5	10
8/03	925	915	235	195	175	55
8/09	1505	616	445	435	395	185
8/16	1115	555	285	265	235	30
8/23	3095	845	755	655	400	10
8/31	4020	1095	550	515	315	45
9/13	3395	620	485	395	345	35

Speculative Mixing Zone

It is clear from the data collected and observations made during the course of this study that many factors influence the shape and areal

extent of a mixing zone at Peoria. Among them are the type of sewer in terms of the degree of submergence and distance from the river, river widths, depths and flows, sewer flows, and probably the wind speed and direction and uses of the river waters. It is also clear that the range of river flows occurring during the study was within a limited range of 6700 to 8500 cfs. And, too, the study was performed at one sewer site among 19 other sewer sites. Under these conditions a prudent course of action would be to present the data, offer some comments on how they may be useful, and rest the case.

However, this study was undertaken for the express purpose of offering judgment on the shape and extent of the mixing zone at Peoria. It was not funded solely to develop a methodology and generate a mass of data. Thus these are compelling reasons to attempt to use the knowledge and relationships that have been gained during this study in the most simplified and conservative fashion for defining a mixing zone. This has been done with two caveats in mind:

1. The data generated must be more rigorously examined to determine their usefulness in a conceptual model such as expressed by equation 3.
2. The observations developed should be verified by additional studies at other sites in Peoria employing similar but less time-consuming procedures.

A mixing zone at Peoria was developed with the following assumptions:

1. Sewer discharges (Q) were the peak flow rates for a storm rainfall intensity of 1.56 in/hr (see table 1).

2. River flows (Q) were the average of the range 6700-8500 cfs observed during the study.
3. The maximum concentration of a constituent in the sewer overflow occurred during peak flow rates (a conservative estimate).
4. All 20 sewers are partially submerged (a conservative estimate).
5. The maximum lateral boundary (D) shall be concentrations representative of 10 percent of the concentration emitted in the sewer discharge. It is defined as:

$$d_p = 515(Q_s/Q_r)^{0.372} \text{ (see table 10).}$$

6. The longitudinal limit of the maximum 10 percent penetration into the river (D) shall be 25 feet.
P
7. At Caroline Street the 10 percent concentration shall be dissipated within the marina.
8. At Darst Street the penetration distance of the 10 percent concentration shall be limited to 50 percent of its calculated value because of basin influences.
9. The maximum penetration of the 10 percent residual after extending 25 feet longitudinally shall diminish with downstream movement, no longer existing at the next downstream sewer site (see figure 27).
10. The allowable mixing zone is an area equivalent to a circle with a radius of 600 feet, i.e., 1,130,972 square feet.

Although the maximum lateral penetration (D) for each sewer site was developed from the relationship $D_p = 515(Q_s / Q_r)^{0.372}$, the values used for estimating the mixing zone were derived from figure 26. The distances between sewers are included in table 1, and the configuration of the proposed mixing zone between sewer sites is depicted in figure 27. The results of pertinent computations are set forth in table 12.

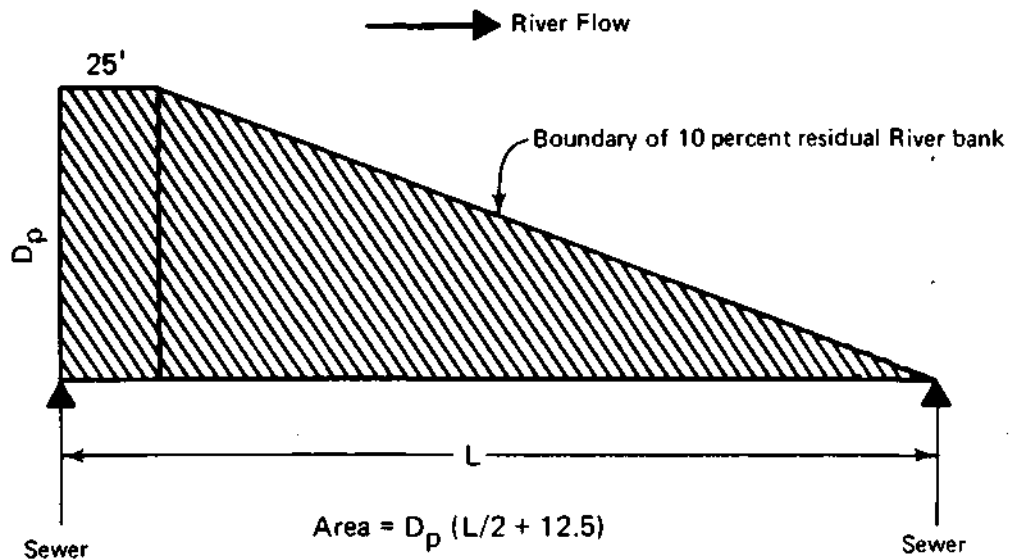

Figure 27. Elements for estimating a mixing zone

Table 12. Physical Characteristics of a Mixing Zone at Peoria

Sewer Name	*Lateral Penetration (Dp)	Percent of River width (%)	*Longitudinal Distance (L)	**Sewer Mixing Zone (A)	**Summation of Mixing Zones (ΣA)
Caroline	0	0	0	-	-
Spring	150	2.1	1637	124,650	124,650
Morgan	70	1.0	1954	69,265	193,915
Green	75	3.0	211	8,850	202,765
Hancock	25	1.0	950	12,188	214,953
Eaton	100	5.0	528	27,650	242,603
Fayette	135	6.8	158	12,353	254,956
Hamilton	40	2.0	370	7,900	262,856
Main	95	5.3	581	28,785	291,641
Fulton	30	2.0	370	5,925	297,566
Liberty	40	3.1	317	6,840	304,406
Harrison	35	2.9	264	5,058	309,464
Franklin	25	3.1	370	4,938	314,402
Walnut	90	12.8	422	20,115	334,517
State	55	7.8	422	12,293	346,810
Oak	105	17.5	2851	150,990	497,800
Cedar	180	22.5	2323	211,320	709,120
South	95	10.5	2218	106,543	815,663
Sanger	60	6.0	2270	68,850	884,513
Darst	90	10.0	1800	82,125	966,638

* feet

** square feet

As shown in table 12, the maximum penetration into the river occurred at the Cedar Street site. Expressed as a percentage of the river width, it was 22.5 percent. Upstream of Oak Street, except for Walnut Street, the maximum penetration did not exceed 8 percent of the river width.

The total area of the mixing zone is 966,638 square feet, representing about 85 percent of an area equivalent to a circle with a 600-foot radius. About 64 percent of the mixing zone lies downstream of the Oak Street sewer.

The procedures used here for estimating a mixing zone may stimulate several questions. A basic one would be: Why choose a 10 percent residual as the boundary for lateral penetration? A review of the concentrations of BOD₅, total suspended solids, ammonia-N, cadmium, copper, lead, zinc, and fecal coliforms occurring in the combined sewer overflows at Peoria indicate, with the exception of total suspended solids and fecal coliform, that a 90 percent reduction in these concentrations would produce overflows in compliance with effluent standards. In other words the mixing zone would provide dilution and dispersion equivalent to secondary treatment. Water quality standards were not a consideration because earlier work suggested that sewer overflows into the river waters, in the absence of a mixing zone, were not likely to violate such standards. Within the assumptions enumerated here the proposed mixing zone, which is considered a conservative estimate, is within the physical limitations set forth in the rules and regulations of the Water Pollution Control Board.

SUMMARY AND CONCLUSIONS

1. Twenty combined sewer overflows exist along the riverfront at Peoria. They represent a variety of shapes, sizes, and outfall conditions and can be generally typed as fully submerged, partially submerged, free fall, and overbank. Each site possesses unique characteristics. Judgment and care are required when extending the data gained during this study to any of the overflow sites.
2. The mixing characteristics of two overflow types at Cedar Street were successfully defined. Simulated overflows were accomplished by pumping river water into sewers. The mixing patterns were traced by adding fluorescent dye to the sewer overflows and collecting samples of the overflow-river mixture.
3. Six overflow simulations were made at the Cedar Street location. Three runs were made using a 24-inch storm pipe discharging on the bank and thence to the river; three runs were also made using the 72-inch partially submerged Cedar Street combined sewer overflow. The mixing influence of the partially submerged sewer was characterized mathematically using a parabolic model. Relationships were developed whereby the lateral projection of the sewer discharge into the river could be predicted. No such relationship could be developed for the overbank discharge; for the low simulation flows utilized, most of the energy was dissipated on the bank and the effluent projection into the river was not well-defined.
4. The lateral and longitudinal mixing were greatly influenced by a number of downstream physical factors. The most important was the effect of recycling cooling water 900 to 1100 feet below Cedar Street. Dye concentrations at similar percentage levels were carried three times farther downstream in the absence of cooling water withdrawal and return. Also, the great variability in stream depth created unusual dye distribution patterns. Barge traffic and wind induced significant variability in the mixing patterns, but the project was not geared to directly isolate and measure these effects.
5. The limited range of river flows (6700-8500 cfs) occurring during the course of the study imposes some constraints on extrapolating the data for lower or higher river flows.

6. Much data have been gathered and presented in a form which may be useful to other investigators who have an interest in pursuing a conceptual mixing zone model.
7. Rational concepts, supported by data and observations, led to a model for predicting the lateral projection of overflow influences on the river for partially submerged sewers.
8. On the basis of the rational approach and certain basic assumptions, a conservative mixing zone for the riverfront at Peoria is proposed.
9. The area of the proposed mixing zone is 85 percent of an area equivalent to a circle with a radius of 600 feet. Its maximum lateral projection is less than 25 percent of the river's width, and 64 percent of its total area lies downstream of the Oak Street overflow.

REFERENCES

- Akima, Hirosha. 1978. "A Method of Bivariate Interpolation and Smooth Surface Fitting for Irregularly Distributed Data Points." ACM Transactions on Mathematical Software. Vol. 4, No. 2, pp. 148-159.
- Anderson, D. D. 1949. The Illinois State Coordinate System. Proceedings Paper, The Seventh Annual Conference on Surveying and Mapping, The University of Illinois, Urbana, May 27-28.
- Bencala, Kenneth E., R. E. Rathbun, A. P. Jackman, V. C. Kennedy, G. W. Zellweger, and R. V. Avanzino. 1983. "Rhodamine WT Dye Losses in a Mountain Stream Environment." Water Resources Bulletin. Vol. 19, No. 6, pp. 943-950.
- Cobb, E. D., and J. F. Bailey. 1965. "Measurement of Discharge by Dye-Dilution Methods." Book 1, Chapter 14, Surface Water Techniques - Hydraulic Measurement and Computation. USGS.
- Fischer, Hugo B., E. John List, Robert C. Y. Koh, Jorg Imberger, and Norman H. Brooks. 1979. Mixing in Inland and Coastal Waters. Academic Press, New Yprk, 483 p.
- Hetling, L. J., and R. L. O'Connell. 1966. A Study of Tidal Dispersion in the Potomac River. CB-SRBP Technical Paper No. 7, FWPCA Region III, 50 p.
- Hubbard, E. F., F. A. Kilpatrick, L. A. Martens, and J. F. Wilson, Jr. 1965. "Measurement of Time and Travel Dispersion in Streams by Dye." Book 3, Chapter A9. Techniques of Water Resources Investigation of the USGS.
- Illinois Pollution Control Board, State of Illinois Rules and Regulations, 1982. Title 35: Environmental Protection, Subtitle C: Water Pollution, Chapter 1: Pollution Control Board, pp. 5-6.
- Lawson, C. L. 1977. "Software for C1 Surface Interpolation." UPL Publication 77-30, August 15.
- Lin, Phillip C. L. 1983. Mathematical Models Associated with Point and Line Source Discharges in Rivers. USEPA Environmental Monitoring and Support Laboratory project report, Cincinnati, OH.
- Maxwell, W. Hall C, and Kuo-Cheng Chang. 1971. Methodology for Synthesis and Optimization of Diffusion Patterns in Flow Systems. University of Illinois Water Resources Center Research Report No. 44, Urbana, IL.
- Neely, W. Brock. 1982. "The Definition and Use of Mixing Zones." Environmental Science and Technology, Vol. 16, No. 9, pp. 518-521A.

Paily, Paily P. 1981. "Mixing Zone Analysis for River Plumes." Journal of the Environmental Engineering Division. ASCE, Vol. 107, No. EE4, pp. 731-746.

Rutherford, J. C., M. E. U. Taylor, and J. D. Davies. 1980. "Waikato River Pollutant Flushing Rates." Journal of the Environmental Engineering Division. ASCE, Vol. 106, No. EE6, pp. 1131-1150.

Sanders, Thomas G., Donald Dean Adrian, and J. Michael Joyce. 1977. "Mixing Length for Representative Water Quality Sampling." Journal Water Pollution Control Federation. WPCF. Vol. 49, No. 12, pp. 2467-2478.

Schiller, Eric J., and William W. Sayre. 1973. Vertical Mixing of Heated Effluents in Open-channel Flow. Iowa Institute of Hydraulic Research Report No. 148, Iowa City, IA, 146 p.

Staff of the Water Quality Section, Illinois State Water Survey. 1983. An Assessment of the Impact of Combined Sewer Overflows at Peoria on the Waters of the Illinois Waterway. Illinois State Water Survey Contract Report 330, 173 p.

Appendix A

Photographs of Combined Sewer Overflow Sites



Spring



Caroline
(Submerged)



Closeup

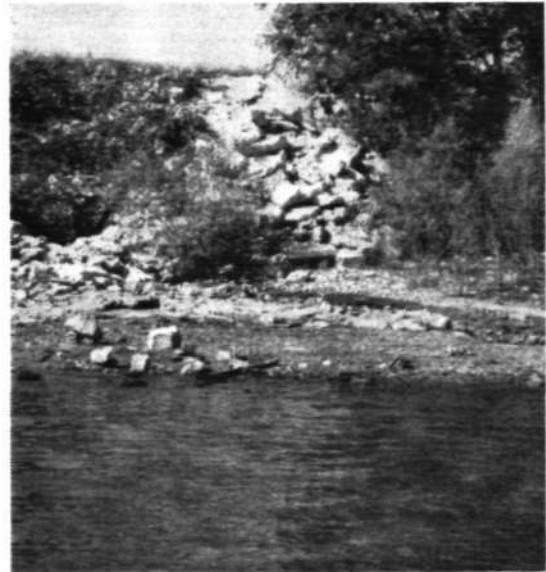

From river

Morgan



Closeup

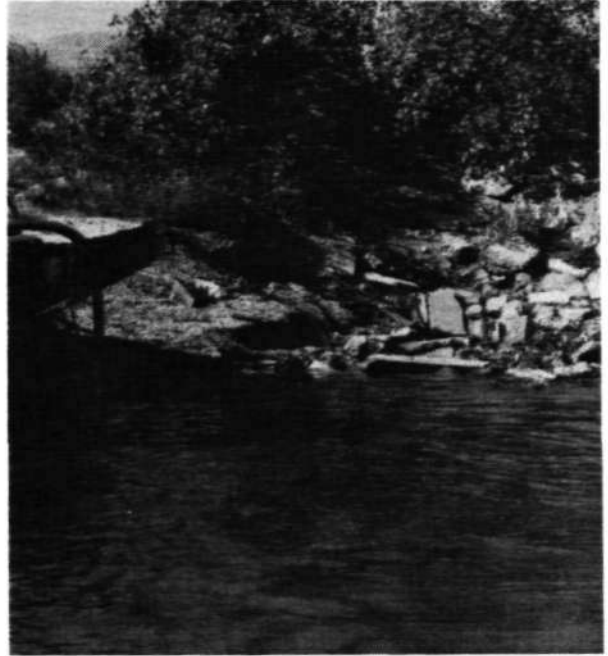

From river

Green

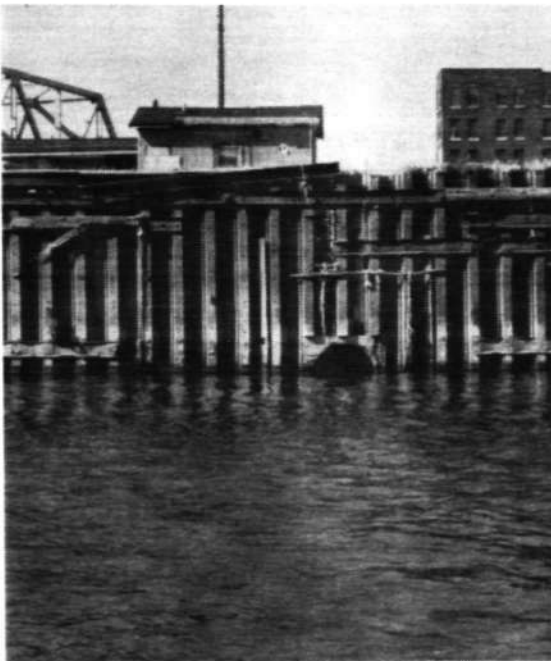

Eaton

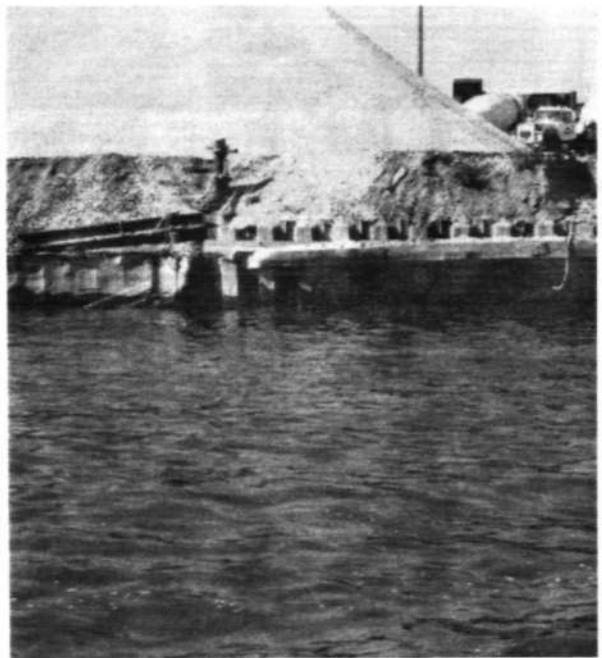

Hancock.

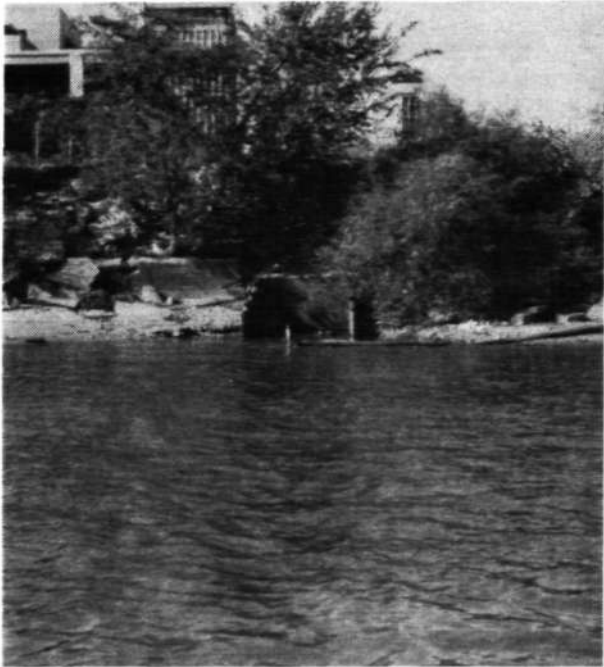

Hamilton

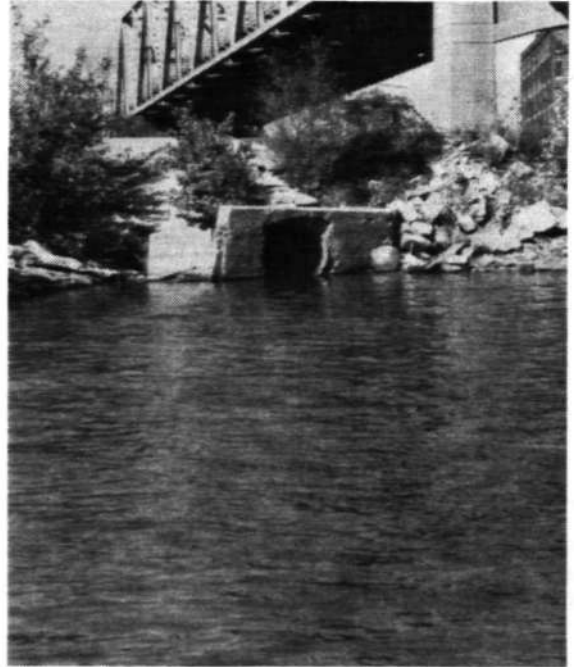

Fayette



Fulton
(Submerged)

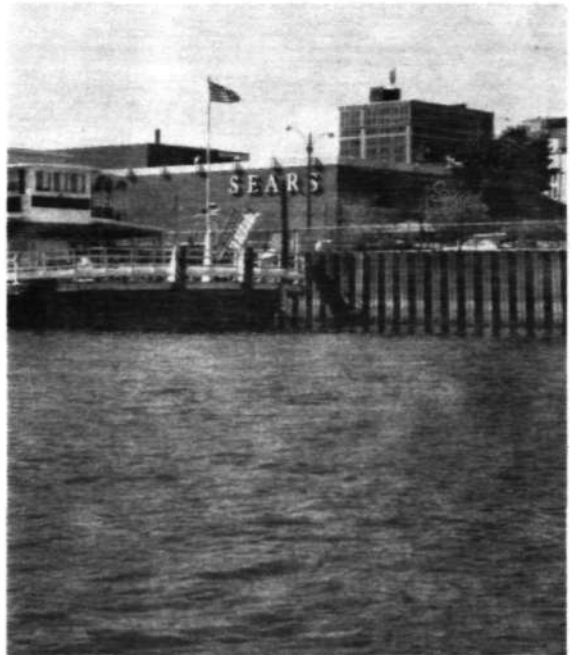

Main

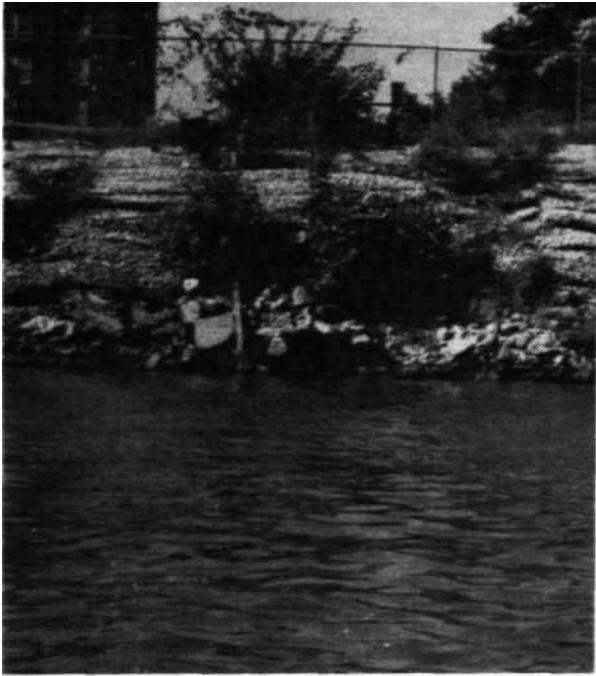

Harrison
(Dark shadow
at river edge)

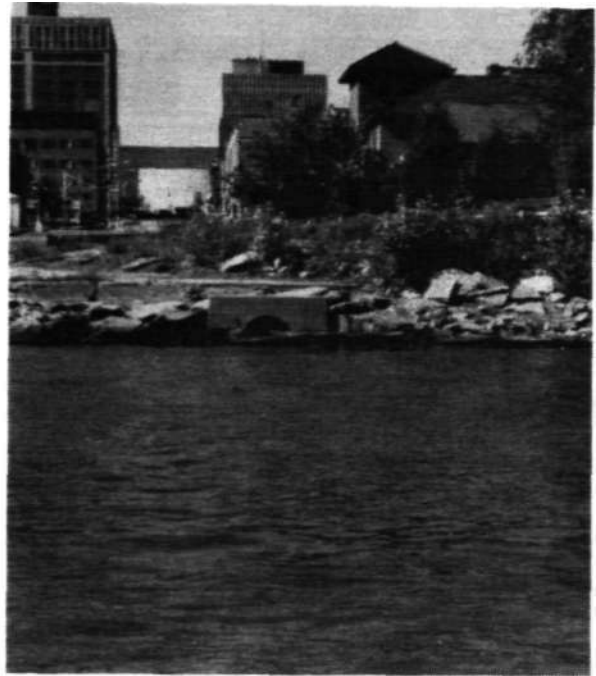

Liberty
(Submerged downstream
of storm sewer headwall)



Walnut

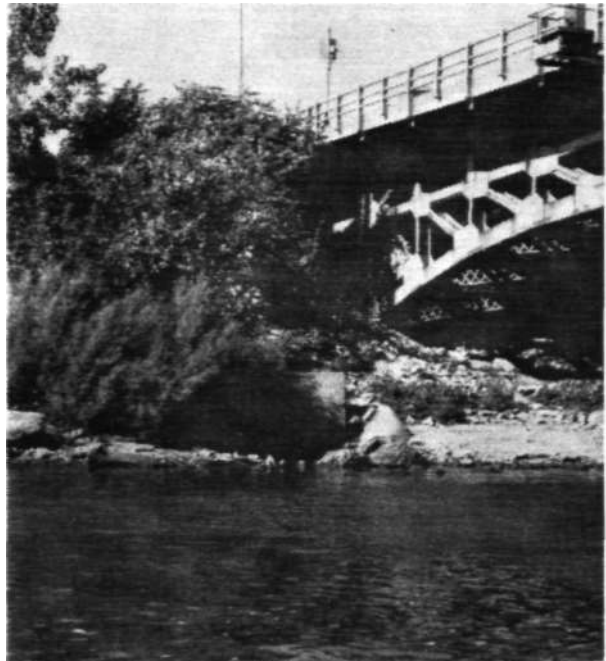

Franklin

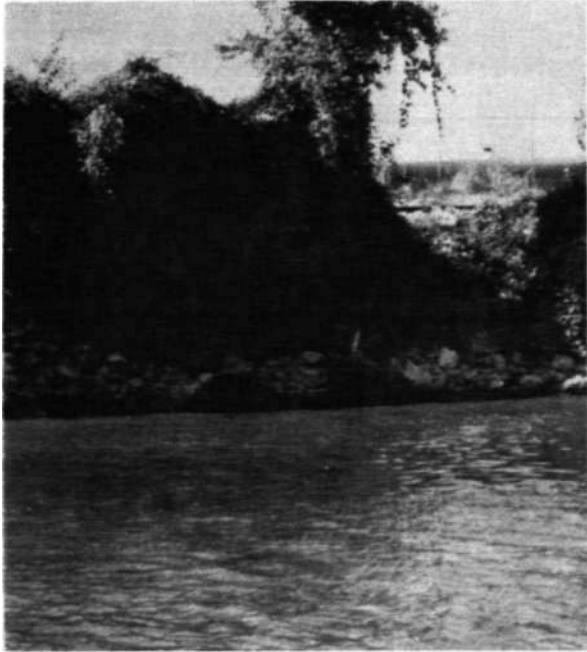

Oak

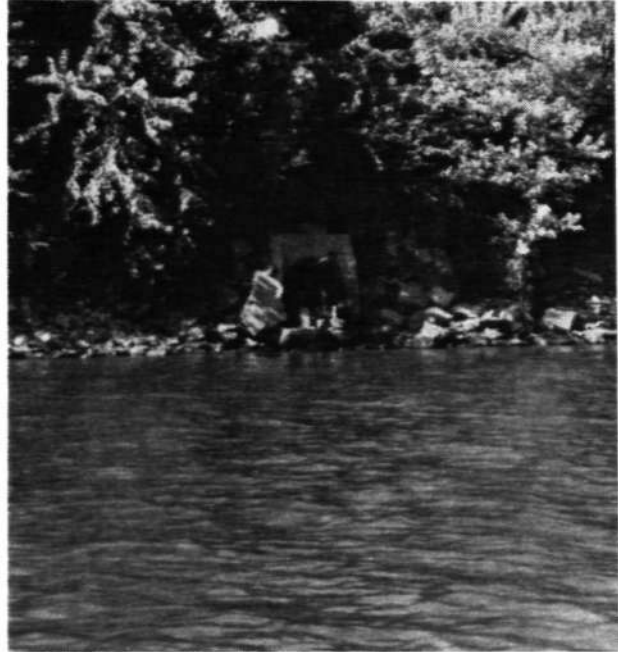

State
(Submerged downstream
of storm sewer headwall)



South

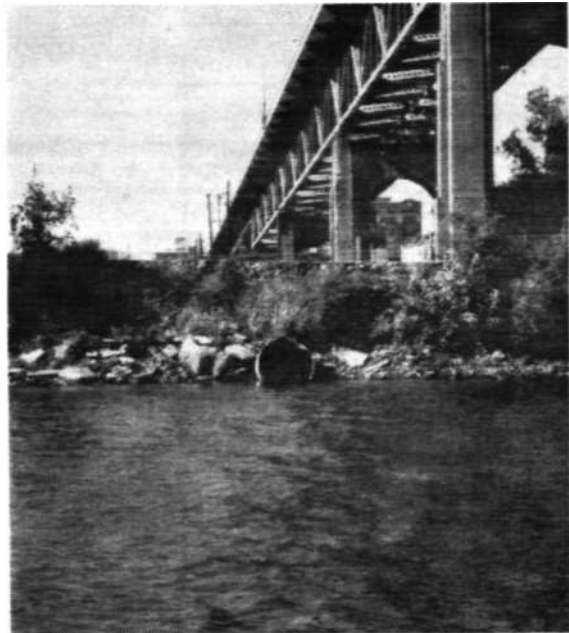

Cedar



Sanger



Closeup inside
bay area

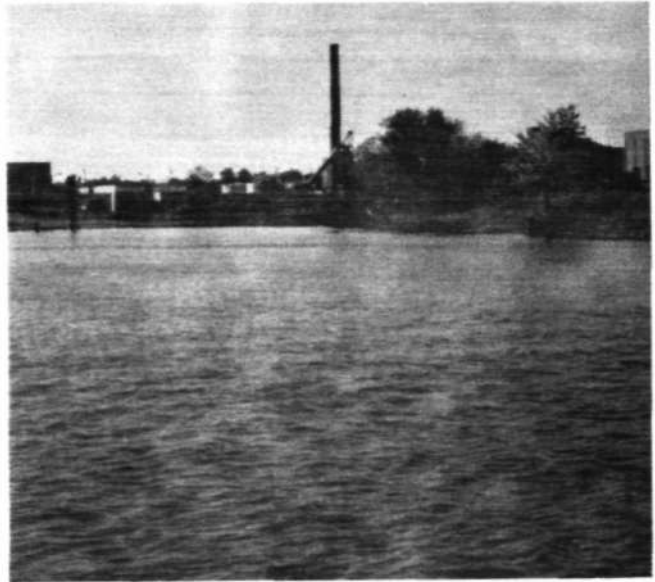

Bay view
from river

Darst

Appendix B
Equipment and Materials Specifications

WATER PUMP AND PRIME MOVER

General Information

- Model: Jaeger Sykes 10L
- Chassis mounted on four pneumatic, 7.75x15 tires
- 12-volt battery starting system
- No fuel tank
- Length = 81 in.; width = 52 in.; height = 80 in.
- Weight = 3900 pounds

Prime Mover

- Model: Ford 380 Diesel
- Six cylinder - water cooled
- Displacement: 380 cu. in.
- Maximum horsepower: 92 @ 2400 rpm

Pump

- Suction: 10 in.; Discharge 10 in.
- Volute: self-cleaning, close grain cast iron
- Seal ring: replaceable bronze
- Impeller: 12 1/2 in. diameter mixed flow, close grain cast iron
- Shaft seal: mechanical grease; special alloy bronze
- Maximum passable solids: 2 in. diameter
- Pumping rates (gpm) at 1550-1700 rpm:

Total Dynamic Head (ft)	Suction Lift (ft.)			
	10	15	20	25
40	3700	3500	2900	2000
50	3550	3400	2850	2000
60	3400	3000	2600	2000
70	3050	2700	2450	1950
80	2700	2450	2200	1900
90	2400	2150	2050	1700

PIPING AND FITTINGS

Piping - Commercial Specifications

- Material: NIPAK Polyethylene Plastic
- Nominal size: 12 in.; Length: 40 ft.(11 sections ordered)
- Cell classification per ASTM D-3350: PE 335434C
- Strength: SDR 32.5(50 psi)
- ID: 11.964 in.; OD: 12.750 in.
- Weight: 6.66 lbs/ft.

Piping-physical Properties

- Densities: 0.955 g/m³
- Melting point: 255°F
- Brittleness temperature: -180°F
- Thermal expansion: 0.00008 in./in./°F
- Tensile yield strength: 3200 psi
- Hydrostatic design stress: 800 psi

Fittings

<u>Item</u>	<u>Material</u>	<u>Mfg. No.</u>	<u>Size(in.)</u>	<u>Quantity</u>
45-el	Polyethylene	SDR 32.5	12	7
90-el	Polyethylene	SDR 32.5	12	2
90-el	Polyethylene	SDR 32.5	10	1
90-tee	Polyethylene	SDR 21	12	1
Flange Adapter	Polyethylene	-	10	1
Flange Adapter	Polyethylene	-	12	3
Convoluted Flange	Steel	-	12	2
Concentric Reducer	Polyethylene	SDR 9	12 x 10	1
Concentric Reducer	Steel	-	12 x 10	1

IN-LINE APPURTENANCES

Couplings

- Manufacture: Morris Coupling Co.
- Material: galvanized steel compression ring and sleeve, red-rubber gasket
- Specifications:

Nominal Size(in.)	O.D. of Pipe(in.)	Model No.	Length (in.)	No. Bolts	Weight (lbs.)	No. Ordered
12	12.75	12-5C	12	5	48.2	32
12	12.75	12-4C	10	4	40.9	1
10	10.75	10-4C	10	4	33.7	1
10	10.75	10-3C	8	3	28.0	1
12	12.75	12-4C-SB	16	4	40.0	4

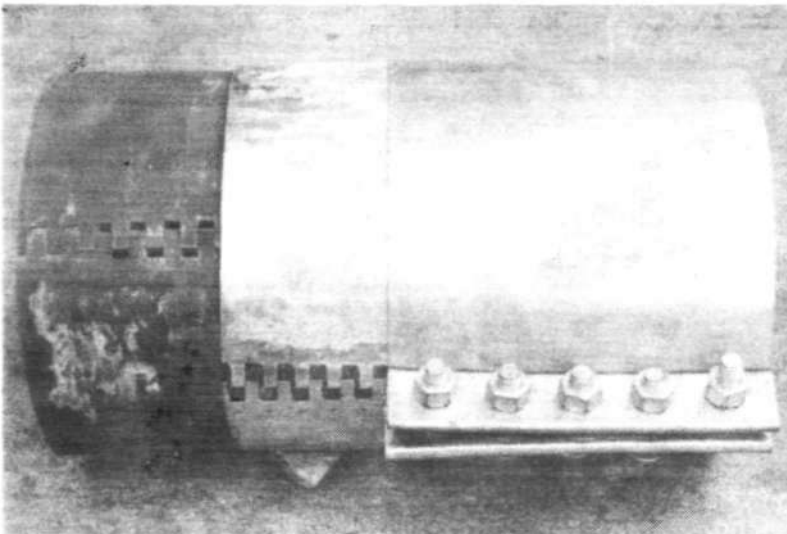

STANDARD COUPLING
Showing rubber gasket
and Steel Sleeve

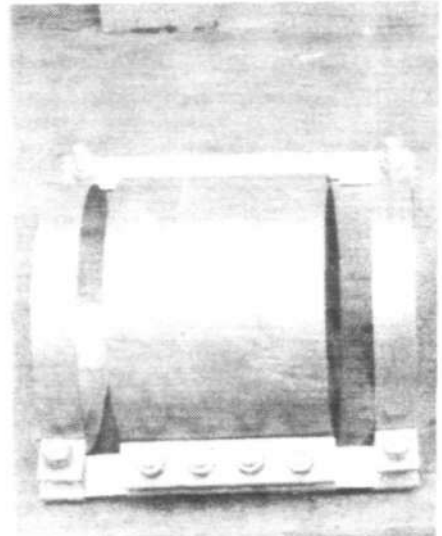

SIDE BAND
COUPLING

Flowmeter

- Manufacturer: AquaMatic, Inc.
- Type: differential pressure - Model FLY
- Nominal size: 12 in.
- Orifice size: 10 in.
- Accuracy: plus or minus 2% for water
- Pressure loss:

<u>Flow (gpm)</u>	<u>Pressure Drop (psig)</u>
700	0.12
1400	0.50
2000	1.02
2800	2.00
3500	3.13

- Meter scale calibration:

<u>Scale Reading(gpm)</u>	<u>Test Reading(gpm)</u>
800	790
1500	1483
2500	2490
3500	3498
4000	4013

FLUORESCENT DYE

- Supplier: Crompton & Knowles Corp.
- Appearance: clear, very dark red aqueous solution
- Commercial concentration: 20% of aqueous solution
- Specific gravity: 1.15 at 20/20°C
- Optimum excitation wavelength: about 556 nm
- Optimum analyzing wavelength: about 580 nm
- pH sensitivity: insignificant fluorescence change between 5.5 and 11.0
- Shipping quantity: 250 pound drums

DYE INJECTION METERING PUMP

- Manufacturer: Fluid Metering, inc.
- Model: RP-B-1-CSY
- Power: 12V, 4a D.C.
- Type: reciprocating RR piston(1/4 in. dia.) positive displacement
- Strokes: 2800 per min. maximum
- Pressure: 70 psig
- Displacement: variable to a maximum 750 ml/min.
- Weight: 8 lbs.
- Size: 11.3 in. x 3.4 in.
- Micrometer: 0.1% settings

- Calibration data

Micrometer Setting	Rate Flow (ml/min)	Observed Flows (ml/min)		
		At Positive Heads (inches) of 8	20	40
0.1	75	122	126	132
0.2	150	236	242	245
0.3	225	354	360	364
0.4	300	471	478	480
0.5	375	579	595	599
0.6	450	689	707	714
0.7	525	706	747	795
0.8	600	717	763	805
0.9	675	743	787	822
1.0	750	759	790	842

SAMPLING PUMP

- Manufacturer: Proven Pumps Corp.
- Model: 365
- Type: Self priming (up to 7 ft. of lift) volute
- Power: 12 - volts D.C.
- Ports: Dual threaded - 3/4 in. external garden hose thread - 3/8 in. NPT internal thread - both suction and discharge
- Size: Length = 6 1/8 in., Width = 3 3/8 in., Height = 2 3/4 in.
- Impeller: rubber
- Pumping rates in gph:

Total Head (ft.)						
1	5	10	15	20	30	40
300	258	240	222	202	150	90

TROLLING MOTORS

- Manufacturer: Minn Kota
- Model: 65C
- Power: 12 Volt D.C.
- Controls: 5 - speed twist grip, forward - reverse switch
- Shaft length: 3 units 30 in., 1 unit 36 in.
- Power Specifications:

Speed Setting	Thrust (lbs.)	Amp Draw
1	5	8
2	10	11
3	15	14
4	20	20
5	26	25

Appendix C
Sampling Collection Form

Sewer Cedar C50
 Pump Rate 1.0 0.5
 Date 8/09/83
 River Flow ≈ 6755
 Time Start 1305
 End 1545
 Temp Start 30.4
 End 30.6

Crew Lin-Beuscher sheet 1 of 8

Sample No.		Sta. No.	Dist.	Depth	Conc.	
1.0	0.5				1.0	0.5
	35	32+75	75			
	36					
	37			3		
	38			0		
	39		50			
	40					
	41			3		
	42			0		
	43		25			
	44					
	45			0		
	46	31+75	100			
	47					
	48			3		
	49			0		
	50		75			
	51					
	52			3		
	53			0		
	54		50			
	55					
	56			2		
	57			0		
	58		25			
	59					
	60			0		
	61	31+25	100			
	62					
	63			3		
	64			0		
	65		75			
	66					
	67			3		
	68			0		
	69		50			
	70					
	71			3		
	72			0		
	73		25			
	74					
	75			0		

Sample No.		Sta. No.	Dist.	Depth	Conc.	
1.0	0.5				1.0	0.5
	1	34+00	100			
	2					
	3			3		
	4			0		
	5		75			
	6					
	7			3		
	8			0		
	9		50			
	10					
	11			2		
	12			0		
	13		25			
	14					
	15			0		
	16	33+25	100			
	17					
	18			3		
	19			0		
	20		75			
	21					
	22			3		
	23			0		
	24		50			
	25					
	26			2		
	27			0		
	28		25			
	29					
	30			0		
	31	32+75	100			
	32					
	33			3		
	34			0		

A Note Concerning Appendix D

Appendix D, "Dye Concentrations as a Percentage of Input Concentrations," consists of 87 tabular data sets, similar to those given in tables 4, 5, and 6, but given in terms of percentages. These data are available as open file data at the Water Quality Section, Illinois State Water Survey, Box 697, Peoria, Illinois 61652.