

**SIDESTREAM ELEVATED POOL AERATION
(SEPA) STATIONS: EFFECTS ON IN-STREAM
DISSOLVED OXYGEN**

by

Thomas A. Butts,
Dana B. Shackleford,
and
Thomas R. Bergerhouse

Illinois Department of Natural Resources
Illinois State Water Survey
2204 Griffith Drive
Champaign, Illinois 61820-7495

ABSTRACT

As a result of increased pollutant loading and low in-stream velocities, dissolved oxygen (DO) levels in the Chicago waterways historically have been low. In 1984 the Metropolitan Water Reclamation District of Greater Chicago (MWRDGC) issued a feasibility report on a new concept of artificial aeration referred to as sidestream elevated pool aeration (SEPA). The SEPA station concept involves pumping a portion of water from a stream into an elevated pool. The water is then aerated by flowing over a series of cascades or waterfalls, returning to the stream.

The MWRDGC proceeded with design criteria for SEPA stations as a result of experimental work performed by the Illinois State Water Survey (ISWS). Five SEPA stations were constructed and placed in operation along the Calumet River, Little Calumet River, and the Cal-Sag Channel waterway. In 1995 the ISWS returned to conduct research to evaluate the reaeration efficiencies and their effects on in-stream DO.

Continuous monitoring of DO, temperature, pH, and conductivity was performed at 14 locations along the Calumet and Little Calumet Rivers, Cal-Sag Channel, and Chicago Sanitary and Ship Canal to evaluate the effectiveness of the SEPA stations on maintaining in-stream DO concentrations. Also, supplemental cross-sectional measurements were made at the 14 locations and at an additional seven locations. Comparisons of mass balance, completely mixed, in-stream mean DO concentrations at the SEPA station outfalls and those measured at cross-sectional stations immediately downstream of each SEPA station were made. Results showed that each SEPA station has an immediate positive impact on in-stream DO concentrations. At SEPA stations 1 and 2, where the impacts are small, the positive effects can best be demonstrated using completely mixed values.

Two important conclusions can be made. One is that the SEPA stations, particularly stations 3, 4, and 5, are fulfilling the intended function of maintaining stream DO standards in the Calumet and Little Calumet Rivers and the Cal-Sag Channel. The second is that DO concentrations less than the DO standard are still observed in the Chicago Sanitary and Ship Canal in the reach beginning above its juncture with the Cal-Sag Channel to the Lockport Lock and Dam. Over the entire study period, DO concentrations were maintained above the standard 98.6 percent of the time from the SEPA station 3 outfall to the intake of SEPA station 4 and 97.5 percent of the time from the outfall of SEPA station 4 to the intake of EPA station 5. Significant improvements in DO concentrations were also achieved for at least 4 miles downstream of SEPA station 5 in the Chicago Sanitary and Ship Canal.

CONTENTS

	<i>Page</i>
INTRODUCTION.....	1
Background.....	1
Study Objectives.....	2
Acknowledgments.....	3
METHODS AND PROCEDURES.....	4
Study Area.....	4
Station Locations.....	4
Monitor Installation Designs.....	5
Study Period.....	7
Field Operations.....	9
Monitor Exchanges.....	9
Cross-sectional DO/Temperature Measurements.....	10
Nitrogen Sampling.....	12
Laboratory Operations and QA/QC Procedures.....	12
Monitor Preparation and Use.....	12
Quality Assurance/Quality Control.....	14
Data Reduction and Analyses.....	15
Probability Analyses.....	15
Comparative Analyses.....	18
RESULTS.....	20
Continuous Monitoring DO.....	20
Temporal (Station) Profiles.....	21
Longitudinal Profiles.....	21
Other Parameters.....	22
Cross-sectional DO/Temperature.....	22
DO Probability Distributions.....	25
DISCUSSION.....	27
CONCLUSIONS.....	39
REFERENCES.....	44
TABLES.....	45
FIGURES.....	78
Appendix A. YSI Model 6000 _{UPG}	121
Appendix B. Continuous, Hourly DO Measurements.....	129
Appendix C. Summary of Continuous Monitoring for pH and Specific Conductance and Manually Collected Nitrogen Data.....	147
Appendix D. Ten Most Variable Cross-sectional DO Patterns Shown with Delimiting Isopleths.....	153
Appendix E. Hourly DO Probability Curves for Each Monitoring Station by Period....	165
Appendix F. Daily Mean Probability Curves for Each Monitoring Station by Period....	199

SIDESTREAM ELEVATED POOL AERATION (SEPA) STATIONS: EFFECTS ON IN-STREAM DISSOLVED OXYGEN

by
Thomas A. Butts,
Dana B. Shackelford,
and
Thomas R. Bergerhouse

INTRODUCTION

As a result of increased pollutant loading and low in-stream velocities, dissolved oxygen (DO) levels in the Chicago waterway historically have been low. During the 1970s, water quality modeling was performed by the Metropolitan Water Reclamation District of Greater Chicago (District) to evaluate the effectiveness of tertiary treatment on reducing the occurrence of low DO levels. The results were not encouraging. The construction of advanced waste treatment facilities at each of the three major District plants would result in the expenditure of hundreds of millions of dollars while producing questionable results. Consequently, the District began investigating in-stream aeration as an alternative for increasing waterway DO concentrations.

Background

During the late 1960s the District considered four in-stream aeration approaches: barge-mounted aeration devices, in-stream mounted mechanical aerators, U-tubes at head-loss structures, and diffused air systems using ambient air blowers or molecular oxygen. The in-stream mechanical system, although the most cost-effective, could not be used because of navigational considerations. The District evaluated the barge-mounted system in Chicago area waterways, but it did not prove to be practical. The U-tubes are not applicable at most locations at which chronic low DO concentrations occur in the Chicago area waterways because such installations require large instantaneous head losses to operate. By default, diffused aeration was selected by the District for supplementing waterway DO at ten locations, and two diffused aeration stations were built. In 1979, the Devon Avenue station was completed on the North Shore Channel. A second aeration station was constructed at Webster Street on the North Branch of the Chicago River and became operational in 1980.

These diffused aeration stations experienced operational and maintenance problems. Prior to building eight additional aeration stations, the United States Environmental Protection Agency (USEPA) deferred on its demands for the District to build advanced wastewater treatment plants while, in turn, endorsing the use of in-stream aeration. This reversal in opinion prompted an immediate search for an improved technological approach to aerating the waterways. In 1984, the District (Macaitis et al.,

1984) issued a feasibility report on a new concept of artificial aeration referred to as sidestream elevated pool aeration (SEPA). The SEPA station concept involves pumping a portion of the water from the stream into an elevated pool. The water is then aerated by flowing over a cascade or waterfall that returns the aerated water to the stream.

Over the next several years, modifications were made to the SEPA station design originally proposed by Macaitis et al. (1984). In particular, Tom Butts, with the Illinois State Water Survey (ISWS), suggested using a stepped-weir system in place of a continuous cascade or one large waterfall. As a result, research scientists from the ISWS and the District's Research and Development Department cooperated in conducting full-scale testing of a sharp-crested weir system during 1987 and 1988. A prototype SEPA station was built along the Chicago Sanitary and Ship Canal at the District's Stickney Water Reclamation Plant. This experimental work led to the development of SEPA station design criteria by Butts (1988). Information and recommendations in this report (Butts, 1988) were used by District consultants to design five SEPA stations along the Calumet waterway system (figure 1). Figures 2-6 are photographs of all five SEPA stations. Table 1 presents waterway mile locations and basic design features of all five SEPA stations.

Study Objectives

Additional artificial aeration stations are being planned for future locations along the Chicago waterway system. But, information is needed on the operating characteristics of the SEPA stations and their effects on DO concentrations in the waterways below their discharge. In a November 25, 1994, letter to James Park of the Illinois Environmental Protection Agency (IEPA), the District proposed a two-year study to accomplish five objectives. Three of these objectives were addressed through a two-phase study, conducted between 1995 and 1997, which was designed to:

- Determine the actual oxygen transfer rate due to the waterfalls at the SEPA stations.
- Determine the actual oxygen transfer rate due to the spiral-lift screw pumps at the SEPA stations.
- Determine the effect of the operation of the SEPA stations on the DO levels in the Calumet waterway system.

This report presents the results and conclusions relative to the third objective. The first two objectives are addressed in a separate report (Butts et al., 1999). The work tasks to address the third objective were deemed the highest priority by ISWS researchers and were performed first. Therefore, this part of the overall study is designated Phase I. Consequently, the studies associated with the first two objectives were designated Phase II.

Acknowledgments

This study was funded by the Research and Development (R & D) and Engineering Departments of the District. Irwin Polls R & D project leader and liaison to the ISWS provided scheduling and sampling input. David Tang of the District's Maintenance and Operations Department provided SEPA station operational data used in this report. Thanks are extended to ISWS personnel Bob Larson and Bill Meyer for their intensive efforts in the field and in the laboratory, which helped make this study successful. Bill Meyer's role was especially significant in that he was responsible for preparing the monitors/dataloggers for field use, downloading and filing data, and performing quality assurance/quality control (QA/QC) procedures.

This report was prepared under the general administration of Derek Winstanley, Chief of the ISWS. The original manuscript was typed by Linda Dexter and edited by Eva Kingston and Agnes Dillon.

The views expressed in this report are those of the authors and do not necessarily reflect the views of the sponsor or the Illinois State Water Survey.

METHODS AND PROCEDURES

The approach used for determining the effects that SEPA stations have on in-stream water quality was to install continuous water quality monitors at critical points along portions of the Calumet and Little Calumet Rivers, the entire Cal-Sag Channel, and the Chicago Sanitary and Ship Canal below its junction with the Cal-Sag Channel. All continuous monitoring data were recorded hourly. Monitors were installed in early spring 1996 and were left in place until late fall 1996. Also, cross-sectional DO readings were made periodically at each monitoring station to generate data for relating mean cross-sectional DO values to the point values generated by the continuous monitors. An ancillary study was performed to determine the extent of in-stream nitrification in the study area waterways.

Study Area

Figure 1 shows the study area. Monitors were installed in the following waterways:

Waterways Evaluated in Study Area

<i>Waterway</i>	<i>Inclusive river mile designation</i>
Calumet River	328.1-326.6
Little Calumet River	326.6-319.8
Cal-Sag Channel	319.8-303.3
Chicago Sanitary and Ship Canal	303.3-291.2

Monitoring was extended to the Lockport Lock and Dam (river mile or RM 291.2) along the Chicago Sanitary and Ship Canal to provide background data for evaluating possible needs for additional aeration below the junction of the Cal-Sag Channel and the Chicago Sanitary and Ship Canal.

Station Locations

The DO data were generated by using remote continuous water quality monitors/dataloggers and periodically measuring and recording DO and water temperatures manually at selected cross-sectional locations. Cross-sectional measurements were made at all continuous monitoring waterway river mile point locations and at supplemental locations considered essential to the development of well defined longitudinal DO profiles. Temperature measurements were made in concert with all DO measurements. Additionally, pH and conductivity were continuously monitored.

Fourteen continuous monitoring sites were established, and seven supplemental manual sampling locations were selected. Manually recorded point (vertical) measurements were made in the outfalls at all five SEPA stations. Table 2 presents the monitoring and/or sampling station locations and descriptions, including river mile points and type of station. Cross-sectional measurements consisted of selecting a number of horizontal locations on transects and measuring DO/temperature at selected depths on verticals at these horizontal locations. Reference to vertical measurement stations indicates DO/temperature readings were taken at selected depths on only one vertical at a location.

Monitor Installation Designs

Various monitor housing and restraining riggings were used at the sampling stations. Variables considered in the designs were benthic conditions, commercial navigation, vandalism, accessibility, and representativeness (with respect to cross-sectional water quality). Three basic designs were developed and used; descriptions and figure numbers are:

Monitor Rigging Designs

<i>Type</i>	<i>Description</i>	<i>Figure number</i>
I	Horizontal bottom line, single shroud	7a
IA	Horizontal bottom line, double shroud	7b
II	Vertical line off wall, attached shroud	8
IIA	Vertical line off wall, 2 attached shrouds	9
IIB	Vertical line off wall, fixed shroud	9
III	Floating shroud	10

Figures 11-15 are photographs of the three basic systems. Table 2 gives the type of installation used at each of the 14 monitoring stations. Schematic diagrams showing the areal locations and rigging layouts for each station are shown (figures 16a-16n). These rigging designs and transect placements were derived through trial runs conducted during the summer and fall of 1995 and by modifying “permanent” installations used during the 1996 monitoring time period.

During 1995, type II installations with monitors were placed at the intakes of SEPA stations 3 (RM 318.08) and 4 (RM 311.55), and type IIA and IIB installations were placed at the Lockport Lock and Dam. Also during 1995, type I or IA riggings were placed at monitoring station 13 (RM 310.70) on the Cal-Sag Channel, the intake of SEPA station 5 (RM 303.63), and monitoring station 17 (RM 302.56) on the Chicago Sanitary and Ship Canal. Monitoring was done at stations 15 and 17 but not at station 13 during this period. Monitoring station 13 is less than 12 feet deep; consequently, the decision not to install a monitor in the rigging for a lengthy trial period was made. This shallow location experiences heavy barge traffic, and a centerline submerged rigging appeared to

be vulnerable to entanglement by passing barge tows. This concern, here and at two similar sites, proved to be justified and expensive.

All monitoring installations were placed into operation between March 13 and 15, 1996. The shallow, type IA installation at monitoring station 13 had remained in place, unscathed, during fall 1995 and winter 1995-1996. Consequently, such a setup seemed safe and was “permanently” installed at this site and at monitoring stations 7 (RM 320.71) and 10 (RM 317.62), among others. However, the rigs at these three sites, including encased DataSonde I monitors, were quickly lost; lost dates for monitoring stations 7, 10, and 13 were April 17, May 2, and April 18, 1996, respectively. DataSonde I monitors were initially installed at all locations instead of the new YSI 6000 units to minimize the trauma of losing a unit from a barge accident. This obviously proved to be a wise decision. To adjust for these losses, a type I rigging was placed along the left bridge headwall at monitoring station 10 (figure 16f), and type II riggings were placed at monitoring stations 7 and 13 as shown on figures 16d and 16h. These placements remained intact during the remainder of the study.

During the 1995 trial run, the type IA rigging placed at the intake of SEPA station 5 was secured with a heavy log chain that eventually was crushed and broken by barges that frequently glide along the wall. Fortunately, the rigging was retrieved undamaged. Consequently, the 1996 permanent installation was provided with a retrieval line secured in the Illinois and Michigan Canal (figure 16j) instead of the chain.

Most type I and IA riggings were retrieved using a side-line attached to a downstream light weight that was attached to the bank as shown by figure 17. The use of a sideline at monitoring station 17 (RM 302.56) was eventually abandoned because it was routinely cut during barge fleeting, a frequent occurrence in this area of the Chicago Sanitary and Ship Canal. During the remainder of the study, this rigging was routinely recovered with a grappling hook. The type I rigging at the intake of SEPA station 1 (RM 328.10) also routinely was recovered with a hook in lieu of a sideline.

Problems were encountered with the original type IA rigging installed at the inlet area of SEPA station 2 (RM 321.32) because of deep flocculent sediment deposits. The sediment problem was not entirely unforeseen. A type IA system was used to raise the monitor off the bottom and keep the shroud from sinking into the muck. However, the extremely flocculent nature of the sediments had not been recognized fully, and this provision failed. Consequently, the type IA rigging was replaced with a type III floating box, which kept the monitors from contacting the bottom.

The installations at the Lockport Lock and Dam are modified versions of the standard type II rigging. The modifications had to be made to accommodate three problems: deep water, extremely variable water levels, and DO stratification. The water depth is normally about 28 feet at monitoring station 21 (figure 16n), but it may drop as low as 15 feet in a few hours when the Lockport Powerhouse releases large amounts of water in anticipation of impending storms. Because of the deep water and high sediment

oxygen demand (SOD) rates, the DO concentrations may vary by as much as 3-4 mg/L from top to bottom.

Table 3 presents the field coordinates of the continuous monitors. The horizontal or transverse distances referenced to either the right or left bank looking downstream, the total water depth at the monitor location, and the probe location referenced to either the water surface or the bottom are presented. Bottom references were used for type I and IA installations; 3 inches from the bottom represents type I riggings, and 6 inches from the bottom represents type IA riggings. The single 6-inch polyvinyl chloride (PVC) shroud raises the monitor 3 inches off the bottom (figure 7a), and the double 12-inch polyethylene shroud raises a unit 6 inches off the bottom (figure 7b). Zero bank distances represent type II installations. Stations marked both right and left are centerline distances.

The riggings at the Lockport Lock and Dam were designed to monitor DO/temperature near the surface, at mid-depth during normal pool levels, and near the bottom. The surface monitor was attached to a float, which permitted the unit to rise and fall with the fluctuating water levels (figure 9). The bottom and the “mid-depth” monitors were permanently attached at fixed position as shown by figure 9. The “mid-depth” reference is somewhat a misnomer because it did not represent this level during fluctuations in pool levels, particularly during severe drawdowns effected in anticipation of storms. One time the float lodged above the water surface in the shroud when the drawdown was rapid and severe, which resulted in a loss of data.

Precautions were taken to minimize damage at locations at which type II installations appeared to be vulnerable to vandalism. The retrieval lines at these locations were locked to heavily weighted, nearly unmovable security lines as shown by figure 8. Vandalism did occur at SEPA station 4 (monitoring station 12). Early in the study an attempt to break the retrieval line by chiseling failed. Welding a steel shroud around the line attachment at the guardrail prevented additional tampering. For type I installations, the side lines, which were used for retrieval, had to be weighted (figure 17) to prevent movement and/or entanglement with barges and to reduce shoreline visibility.

Study Period

The monitoring period was from 0000 on March 16, 1996, to 2300 on November 19, 1996. During this period, in-stream water quality was influenced by SEPA station pumping rates and Lake Michigan diversion water, both controllable, and uncontrollable weather.

Within the overall time frame, SEPA station pumping rates and Lake Michigan discretionary diversion were to be held constant for weekly periods during which manual cross-sectional DO/temperature runs were to be made under steady-state conditions.

Fifteen manual cross-sectional runs were planned under controlled conditions as outlined in table 4. However, the goal of controlling discretionary diversion was not met,

even to a limited degree. Periodic drawdowns in anticipation of heavy rainfall, heavy runoff from actual storms, and other operational considerations precluded adherence to the proposed diversion schedule. On three occasions, as noted in table 4, mechanical problems in the SEPA stations disrupted pumping schedules. Consequently, the information collected during the runs was mostly randomized and could not be used to statistically evaluate selective stable conditions.

Table 5 presents the diversion and SEPA station pumping rates inclusive of the 1996 in-stream study period. The dates in bold face type represent the implementation periods for events 1 and 2 of the Phase II part of this study. During these periods, SEPA station pumping rates were set by the SEPA station aeration efficiency study plan. The remaining pumping rates were set as needed by the District to meet minimum in-stream DO standards.

The monitors were exchanged biweekly during spring and fall because biological buildup on the probes was minimal then. Biweekly exchanges were made March 15-June 12, 1996, and August 30-November 20, 1996. Weekly exchanges to minimize biofouling were done during the summer, except during the summer event of Phase II of the SEPA study. Two weeks elapsed before an exchange could be made because the monitors normally reserved for exchanges were in place within SEPA stations 3, 4, and 5 during the Phase II portion of this study.

The SEPA station pumping rates were reduced below desirable levels on several occasions due to either mechanical problems or voluntary shutdowns for the application of herbicides to control aquatic weeds within SEPA station pools. In particular, SEPA station 3 experienced mechanical problems that required pump shutdowns. Factors that disrupted scheduled pumping plans or in-stream DO needs are:

Disruptions to Scheduled Pump Operations for SEPA Stations, 1996

<i>SEPA station</i>	<i>Period</i>	<i>Condition</i>	<i>Pumps available</i>
4	06/11–06/13	Weed control	0
3	06/21–06/26	Mechanical problems	1
3	06/27–07/18	Mechanical problems	2
3, 5	08/02–08/06	Weed control	0
4	08/06–08/09	Weed control	0
3	10/07–10/11	Mechanical problems	2

As shown on table 5, only one pump was operated throughout the study period for SEPA stations 1 and 2. Additional pumping rates at these two locations were not warranted during the study.

Field Operations

The field riggings were used by two, three-person boat crews during early March 1996. Thereafter, routine weekly or biweekly monitor exchanges were made at the 14 sites using two, two-person boat crews. Periodically, three, two-person boat crews would take cross-sectional or vertical DO/temperature measurements at the 21 stations (table 2). Fifteen cross-sectional runs were made; and samples were collected during ten of the cross-sectional runs for nitrogen analysis in the laboratory.

Monitor Exchanges

The monitors were transported in 6-inch, PVC shrouds (shown schematically in figure 7) and in a field boat (figure 18). The shroud and monitor encasement system was designed to provide an expeditious and safe means of transferring, transporting, and exchanging the monitors. Most of the exchanges were done via boat, with the exception of monitoring station 21 at Lockport (RM 291.20), which was always done by land. Occasionally monitors at the intakes of SEPA stations 3 (RM 318.08) and 4 (RM 311.55) were exchanged by land.

All field activity associated with boat-related exchanges and cross-sectional runs originated at the Alsip boat-launching ramp (RM 314.00) between SEPA stations 3 and 4. One boat crew would exchange units at the six stations above this location; a second boat crew would exchange the seven water-accessible units below this location. All exchanges were usually completed within five to six hours. The three units at monitoring station 21 (Lockport) were usually exchanged the afternoon or evening prior to the day of the boat exchanges. Also, the occasional land exchanges at monitoring stations 9 and 12 usually were done the afternoon prior to the boat exchanges.

Type I and IA riggings were retrieved by side lines (or modified versions thereof) at monitoring stations 2 (figures 16b), 10 (figure 16f), 14 (figure 16i), 15 (figure 16j), 16 (figure 16k), and 18 (figure 16m), and by using a grappling hook at monitoring stations 1 (figure 16a) and 17 (figure 16l). The side line at monitoring station 14 often had to be lifted with a hook. Figure 11 shows the retrieval/exchange of a type I rigging, and figure 19 shows the retrieval of a type IA rigging; figures 20 and 21 show the exchange of DataSonde I and YSI 6000 units, respectively, at a type IA station.

Monitor/shroud combinations were retrieved at type II sites by unlocking a padlock, thereby releasing the retrieval line from the security line (figure 8) and pulling the unit into the boat (figure 13). At the type III installation at monitoring station 6 (SEPA station 2 intake), the monitor was removed from the transporting shroud and placed into the box shroud or float (figure 15) and restrained as shown schematically by figure 10.

For type I and II installations, the combination shroud and monitor was replaced during each exchange. For type IA installations, the shroud was replaced with the monitor only when sedimentation and biofouling dictated a need to do so. All monitors and

exchanged shrouds were scrubbed with water and a stiff-bristled brush immediately upon removal from the water. Care was taken not to disturb the probes when washing and cleaning the units.

The monitors were protected from jarring and shock inside the PVC shrouds by two thick rubber bushings shown on the YSI 6000 monitor in figure 21 and schematically illustrated on figure 7. The units were secured in the shrouds with ½-inch bolt-pins inserted through the monitor hangers as shown schematically by figure 7 and in reality by figure 12. The pins were restrained with washers and hitch-pin clips (figure 7).

The standard operation procedures (SOPs) and QA/QC methods used relative to the use of the monitors will be outlined and described later.

Cross-sectional DO/Temperature Measurements

Cross-sectional measurements were made at 19 of the 21 stations listed in table 2. Measurements were made on single verticals at 2-foot depth intervals at station 3, the lakeside entrance to the O'Brien Lock and Dam, and monitoring station 21, the entrance to the Lockport Powerhouse forebay. The cross-sectional measurements were made at 13 of the monitoring sites and on the vertical at Lockport Lock and Dam to generate data for developing statistical relationships between the DO levels at the fixed monitoring points and cross-sectional (and the Lockport vertical) means. The intent was to determine if these point measurements represent cross-sectional means and, if not, to develop statistical regression equations that could be used to estimate cross-sectional means. Measurements at sites intermediate to the monitoring locations were selected to generate data to better define the DO sag curves in reaches of the waterway influenced by SEPA station operation. Also, DO/temperature readings were taken in the outfalls of each SEPA station during their operation. The outfall locations are indicated by "Out" in table 2.

A minimum of ten cross-sectional runs was originally planned. However, 15 runs were completed from March 28-November 13, 1996. The intent during the ten originally scheduled runs was to establish steady-state lake diversion and steady-state pumping rates at SEPA stations 3, 4, and 5 for five days prior to performing the in-stream measurements. These conditions were to be extended to seven days to allow ample time for completing the in-stream work. However, as noted earlier, weather and mechanical problems prevented the District from adhering to any planned schedule as demonstrated by the data in table 4.

Three, two-person boat crews conducted the cross-sectional DO/temperature measurements. The procedure that was developed minimized the sampling time length. One crew started at monitoring station 1, and another crew started at monitoring station 21. Each crew worked toward the middle and the third crew. Whenever two crews met and finished, they would help the third crew finish. Often the crew working at the upper stations would be delayed during passage through the O'Brien locks, and the two crews

working at the lower stations would complete the sampling. Except on a few occasions, all cross-sectional data were collected on the same day.

At stations along the Cal-Sag Channel, cross-sectional point-measurements were recorded on a minimum of five verticals. Only points on three verticals were sampled along the Chicago Sanitary and Ship Canal because of its relatively narrow width and rectangular cross-sectional shape. At all transects, except those at the SEPA station intakes and those located immediately below the SEPA station outfalls, initial DO/temperature readings were taken at the surface, 3-foot, mid-, and bottom-depths. If significant differences were observed between any of the values, additional readings were taken to establish a representative profile. At intake and below-outfall transects, vertical readings were made at 2-foot increments, unless greater distances were warranted because of uniformity in the measurements. Also, at each transect with continuous monitors, readings were taken as close as possible to the monitor to generate comparative data. During the late fall, the cross-sectional DO levels varied little—either transversely or vertically—at given locations. Consequently during this period, DO/temperature readings were generally restricted to a centerline vertical.

The water edges were marked with fluorescent-orange traffic pylons. Horizontal locations were measured with a Lietz Model 6090 rangefinder by focusing on the pylons. Vertical depths were determined with fishing downriggers equipped with depth counters (figure 22). The DO/temperature measurements were made using a YSI Model 59 DO/temperature meter fitted with a YSI Model 5795A stirrer and a Model 5739 DO/temperature probe.

The DO meters were constantly checked for drift and errors during the field runs. Initially, saturated water was used to calibrate the meters and for checking meter accuracy. A five-gallon bucket of clean tap water was aerated to saturation, and the three boat crew meters were checked for uniformity at the dock before departing. Meters deviating by 0.2 mg/L DO or greater from the other meter readings were recalibrated or replaced if necessary. All boats carried backup meters, probes, stirrers, and extra replacement D-cell batteries.

The saturated water calibration technique was convenient, but it was found inadequate during warm weather. The DO-saturated water was cool in the morning. But as the day progressed it warmed, and the DO concentrations became supersaturated and unstable. Consequently, air calibration was used during the summer. Air calibration was done in a specially designed air-calibration chamber, which could accommodate the stirrer/probe combination. For temperature stability, the chamber contained an outer cooling jacket filled with water (figure 22).

The DO meter was calibrated to 100 percent air saturation before beginning cross-sectional measurements. After the last measurement, the stirrer/probe was immersed in the 100 percent DO-saturated water or sealed in the air calibration chamber and left to equilibrate while in transit to the next station. Upon arrival at the next station, the

temperature in degrees Centigrade (°C), DO in milligrams/liter (mg/L), and percent saturation were recorded. The meter was then adjusted to 100 percent saturation, and the cycle was repeated. The end readings were used to make incremental temporal adjustments in DO readings due to meter drift over the time period required to complete a transect and the start of the next. Proportionate, linear extrapolation was used to make the temporal adjustments in DO.

Nitrogen Sampling

Water samples were collected at the depth of the monitors at all 14 sites for laboratory analyses of ammonia-nitrogen (N), nitrite-N, nitrate-N, and Kjeldahl-N using a 1 L Kemmerer sampler. From this, 250 mL of unfiltered water was retained for Kjeldahl-N analysis and another 250 mL was filtered for ammonia-N, nitrite-N, and nitrate-N analyses. Filtering was done with a Katadyn Model 2050 field pressure filter equipped with a 0.2 µm diatomaceous earth filter element. All samples were iced. Upon completion of a run, samples were immediately transferred to the District's Stickney laboratory for chemical analyses. Collections were made on ten dates.

Laboratory Operations and QA/QC Procedures

Monitors were prepared in the laboratory for field use, data were downloaded, QA/QC measures were applied, and data were reduced and computer filed. Regimented procedures were developed for performing each of these work tasks and were adhered to throughout the study. Many of the SOP and QA/QC methodologies used in this study were developed over the past 15 years and applied to numerous studies. These procedures are more stringent and more detailed than the manufacturer's recommended SOP and QA/QC methodologies.

Monitor Preparation and Use

Principally, two types of continuous monitors were used during the study: HydroLab DataSonde I units and YSI 6000 units. Also, on a few occasions a DataSonde 3 unit and a YSI 6920 unit were used. Between March 15 and May 21, 1996, only DataSonde I units were used. The reasons were twofold: the chance of losing a new YSI unit was too great until the "bugs" were eliminated from the installation rigging designs and site locations, and each YSI had to be tested and put through vigorous QA/QC procedures before it reliably could be placed in the field. Also, DataSonde I units were used almost exclusively during the Phase II study dates, which are highlighted with bold face type in table 5.

Appendix A presents the manufacturer's YSI Model 6000 performance specifications and SOP for the Model 6000 units that were developed by the ISWS for use of the instruments. The SOP for use of the DataSonde I units are basically the same as those for the 6000 units, with a few minor exceptions. Identical QA/QC methodologies were applied to both types of monitors.

The YSI 6000 monitors were calibrated for DO, pH, and specific conductance in the laboratory. All calibrations and downloading were performed using the PC6000 software provided with the monitors. Data files were downloaded in the proprietary PC6000 format and converted within PC6000 to comma-delimited values for importing into Microsoft Excel Version 7.0. Hydrolab DataSonde I units were calibrated using the standard Windows 95 terminal program. Data files for the DataSondes were downloaded as ASCII capture files and imported into Excel. After formatting in Excel, the data were moved into a Microsoft Access 97 database in which all calculations and statistical reductions were performed.

Calibration of pH was performed using Fisher Scientific buffers of pH 7.0 and 10.0. Before calibration, the probes were cleaned and rinsed with de-ionized water and pH 7.0 buffer to remove any contamination. Probes then were placed in 500 mL of the pH 7.0 calibration buffer and allowed to stabilize for ten minutes, or until the electrode readings were stable. The probes then were removed from the solution and rinsed in a beaker of de-ionized water. Prior to placement in the pH 10.0 calibration buffer, the probe assembly was rinsed with pH 10.0 calibration buffer to remove any residual pH 7.0 buffer or de-ionized water droplets that might contaminate the pH 10.0 calibration buffer. The probes then were immersed in a beaker containing 500 mL of pH 10.0 calibration buffer and allowed to stabilize for ten minutes, or until stable readings were obtained. Upon acceptance of the pH 10.0 calibration, the probes were rinsed again and returned to the pH 7.0 calibration buffer to verify calibration. Calibration buffers were checked periodically with an Orion model 920A bench-top pH meter equipped with a model 91-56 pH electrode. Hydrolab instruments were calibrated similarly, except that the amount of buffer used was reduced because the calibration cups were smaller.

Specific conductance was calibrated using a conductivity standard of 1.413 millisiemens/centimeter (mS/cm) at 25°C. The standard was made by diluting a stock solution of 12.880 mS/cm at 25°C. The standard was checked using a Labcraft model 264-774 conductivity meter calibrated to commercially prepared standards. Probes were cleaned and prerinsed with the conductivity standard before immersion in 500 mL of the calibration standard. Calibration was accepted after a ten-minute interval if all readings were stable. Cell-constant values were confirmed to be within the correct operating range. Units with “out of range” cell constant values were cleaned and recalibrated. Cell constants could not be checked on the DataSonde I units because of limitations of the internal software.

Because conductivity is used by the internal software of the units to calculate DO, DO had to be calibrated after specific conductance. Dissolved oxygen probe membranes were changed at least 24 hours before calibration prior to each use to allow for relaxation of the membrane. The probe assembly was rinsed with de-ionized water prior to calibration. Care was taken to ensure that no water droplets were present on the membrane.

For the YSI units, calibration cups containing moist sponges were installed. The instruments were laid longitudinally with the DO probes on top to reduce the chance of water dripping onto the DO membranes. The monitors were run for at least ten minutes in the discrete sampling mode to warm the electrodes and confirm the environmental stability within the calibration cups. Calibration for DO began with compensation for barometric pressure that was obtained from the National Weather Service and adjusted to the elevation of the laboratory.

Hydrolab instruments were calibrated in an inverted position in a specially designed, open-bottom calibration cup. Calibration cups were filled with tap water to levels below an o-ring holding the DO membrane on the electrode. Care was taken to ensure that the membranes were free of water droplets. Rubber caps were lightly placed over the open cup bottom to isolate the probe from ambient air currents. The instruments do not require a warmup, and they automatically compensate for atmospheric pressure. The instruments are run in a calibration mode until acceptable, stable calibrations are obtained.

Quality Assurance/Quality Control

The data generated by the continuous monitors are subject to a certain amount of drift. This drift is a combination of two factors: calibration drift inherent to sensor design and operation, and drift caused by environmental conditions such as the buildup of foreign material on the sensors. Therefore, corrections were applied to the DO measurements obtained by the monitors to compensate for such drift. Drift compensation was performed in Access 97 through a Visual Basic software program developed by ISWS personnel. The program consisted of a combination of pre- and postuse Winkler DO-values, and field values obtained using the YSI Model 59 DO/temperature meters as outlined in the In-stream Placement/Retrieval section of appendix A.

The drift adjustments can be expressed mathematically in equation form as:

$$co_{ti} = mo_{ti} - \left\{ (mo_1 - co_1) + \left[\frac{(mo_2 - co_2) - (mo_1 - co_1)}{t_2 - t_1} \right] (t_i - t_1) \right\} \quad (1)$$

where:

- co_{ti} = corrected DO, mg/L at time t_i , days
- mo_{ti} = monitor DO, mg/L, to be corrected at time t_i
- mo_1 = monitor DO, mg/L recorded at time t_1 , days
- co_1 = correct YSI 59/Winkler DO, mg/L at time t_1
- mo_2 = monitor DO, mg/L, recorded at time t_2 , days
- co_2 = correct YSI 59/Winkler DO, mg/L at time t_2

The equation adjusts for drift between two known points of time. The number of sequential linear adjustments to be made depends on the number of intermediate QA/QC DO measurements made during a run. For in-stream use, only beginning and ending

measurements were made. These include beginning and ending Winkler DO values in the laboratory water tank and beginning and ending YSI Model 59 meter DO values in the field. During Phase II, a number of intermediary measurements also were included.

The cross-sectional DO readings were corrected for meter drift using linear extrapolation. However, these adjustments were proportioned in terms of percent saturation because the meters were calibrated to 100 percent of saturation (using either water or air) at the initiation of cross-sectional measurements. Mathematically this can be expressed as:

$$cm_{t_i} = \left\{ \frac{p_1 + [(t_i - t_{p1}) / (t_2 - t_{p1})] (p_2 - p_1)}{100} \right\} m_{t_i} \quad (2)$$

where:

- cm_{t_i} = corrected YSI meter DO, mg/L at time t_i , minutes
- p_1 = DO percent saturation at time t_1 , minutes
- p_2 = DO percent saturation at time t_2 , minutes
- m_{t_i} = YSI meter DO, mg/L at time t_i , minutes

Generally, p_1 equals 100 percent in equation 2.

The YSI Model 59 meter readings, which are substituted for co_2 in equation 1, were not corrected using equation 2. The meters always were calibrated to 100 percent of saturation at the monitoring sites when deploying or retrieving each unit. The time lapse between the initial calibration and the in-stream reading usually was less than 20 minutes. A drift up to 0.2 percent DO saturation in the meter reading was acceptable. If the drift was greater than 0.2 percent DO saturation, the meter was recalibrated and the in-stream reading was remeasured. The meter was replaced if it continued to drift.

Data Reduction and Analyses

The enormous amount of field data recorded at the in-stream monitoring sites had to be reduced and grouped so that meaningful mathematical and statistical analyses could be performed to determine the effects of SEPA station operations on in-stream water quality. The variability in DO concentrations was of primary interest and, therefore, subjected to in-depth analyses and statistical testing. The other monitor parameters—pH, specific conductance, temperature, and the nitrogen data—were reduced and broadly summarized using basic statistical parameters.

Probability Analyses

The DO data were statistically compared to various IEPA (1993) stream DO water quality standards. These standards are summarized below:

Stream Dissolved Oxygen (DO) Water Quality Standards for Study Area

<i>Name</i>	<i>Reach</i>		<i>Type of standard</i>	<i>DO (mg/L)</i>	
	<i>Inclusive RM</i>			<i>16-hr average</i>	<i>minimum</i>
Calumet River	333.2–326.6		General use	6.0	5.0
Little Calumet River	326.6–319.7		Secondary contact		4.0
Cal-Sag Channel	319.7–303.3		Secondary contact		3.0
Chicago Sanitary and Ship Canal	303.3–291.2		Secondary contact		4.0

An overall analysis of the data was made for the 249-day study period. However, because of the extreme variations in flow, weather, and SEPA operation, six additional analyses were made to account for these variables as presented in table 6. Descriptions of the scenarios in table 6 are:

Study Period Scenarios, March 16–November 19, 1996

<i>Period</i>	<i>Dates</i>	<i>Description</i>
1	03/16-04/18	No diversion without SEPA operation during cool weather
2	04/19-05/30	Low diversion with SEPA operation during cool weather
3	05/31-07/03	Low diversion with SEPA operation during mild weather
4	07/04-09/25	High diversion with SEPA operation during hot weather
5	09/26-10/31	High diversion with SEPA operation during cool weather
6	11/01-11/19	No diversion without SEPA operation during cold weather
1- 6	03/16-11/19	Total study period

Probability statistics were used to estimate the frequency at which the DO standards were not met during the study periods. Frequency distribution curves (FDCs) were used to estimate when DO standards were not met for hourly and mean daily values. The ordinates (percent exceedance values) on the probability graphs were computed by the formula:

$$P = \frac{100(n - 0.5)}{N} \tag{3}$$

where:

- P = ordinal percentage
- n = ordinal number
- N = sample size

This formula was used to negate the computation of a 100 percent plotting ordinate. All future text, table, and graphic reference to the results derived by equation 3 will be referred to as FDC results.

A second, more limited approach was taken for ascertaining the probability of DO standards not being met. The hourly DO concentrations at each monitoring station were assumed to be normally distributed. This assumption permitted probabilities to be determined by computing the standard deviations and comparing them to the normal cumulative distribution curve or a statistical-reference z-table. The FDC development is independent of the normality assumption.

The mean and standard deviation of the daily mean monitor outputs were computed for each station, and the percentage of times in which DO concentrations were less than the DO standard were calculated. The procedure is as follows:

- Compute the standard deviation of the sample,

$$s = \sqrt{\frac{\sum(x - \bar{x})^2}{N - 1}} \quad (4)$$

where:

s = standard deviation of the sample
x = discrete sample value
 \bar{x} = mean (arithmetic average) of sample
N = sample size

- Compute the z-statistic,

$$z = \frac{x_i - \bar{x}}{s} \quad (5)$$

where:

x_i = any discrete or specified value

- Look up percentage value in a statistical reference z-table.

Computed percentages should be very accurate, even if the sampling distribution is only approximately normal because extremely large sample sizes are involved in the calculations. Large sampling theory applies to sample sizes of 30 or greater. Generally in this study, samples sizes were much greater than 30. For hourly analyses, N is in the hundreds; for daily means, N exceeds 30 except for period 6 (table 6). All future text, table, and graphic results derived by equation 5 will be referred to as z-T results.

The basic statistical parameter computations, the FDC developments, and the z-T data generation were done using Microsoft Excel.

Comparative Analyses

Statistical analyses were performed to determine if significant differences existed between data groupings generated during this study. Statistical analyses were performed using standard computer programs capable of handling the large number of data generated. Tests were performed using various analyses of variance (ANOVA) procedures, *t*-tests, and multiple range analyses. Either “normal” or rank-order techniques were applied, depending on the condition of the data. Data were first tested for normality. If the data appeared to fit a normal distribution curve with a 95 percent degree of confidence, statistical tests applicable to “normal” data were used. When the data were not normally distributed, nonparametric, rank-order testing was performed. These tests provided a robust means of testing for differences in data sets that do not fit normality testing criteria.

The nonparametric Mann-Whitney Rank Sum Test was used to determine if differences existed between average cross-sectional DO concentrations and point values measured at the monitor locations in the cross sections. The cross-sectional averages were computed either by straight averaging or by weighted averaging. All cross-sectional data were thoroughly examined and evaluated, and only those sections that exhibited significant variability in DO throughout were weight-averaged. Only 10 of the 195 cross-sectional DO profiles generated required weighted averaging. Of interest is the fact that seven of the ten situations occurred either at the SEPA station 2 intake transect or at transects located immediately below the SEPA station outfalls.

Weighted averages were computed using isoplethic diagrams. Isopleths are lines on a cross section connecting points at which a given variable has a specified constant value. The DO isopleths were drawn on the cross sections at either 0.25 or 0.50 mg/L intervals. A computer program was developed for placing the lines between two DO observations proportionate to the distance between the points based on the difference between the isoplethic value and the two observed values. The areas encompassed between the isopleths were computer generated. Each areal DO concentration was weighted in proportion to its area relative to the total cross-sectional area. The areal DO concentration was taken as the average of the two encompassing isopleths, i.e., if the area was demarked by 3.5 mg/L and 4.0 mg/L lines, the areal representation would be 3.75 mg/L.

A parametric *t*-test was used to determine if the differences between the cross-sectional DO weighted and unweighted averages were statistically significant at the 95 percent confidence level. The outcome of this test was used to decide if point source continuous monitoring data could be used to estimate or represent mean or arithmetically averaged cross-sectional DO concentrations.

A parametric one-way ANOVA test was used to determine if statistically significant differences existed between the mean near surface, “mid-depth”, and bottom DO values at the Lockport Lock and Dam vertical (monitoring station 21) for dates during which measurements were made at 2-foot depth intervals. Additionally, the nonparametric Kruskal-Wallis one-way ANOVA test for ranks was used to determine if statistically significant differences existed at the 95 percent confidence level for the medians of the hourly DO values recorded at the three depths over the course of the study. The rank-order ANOVA test was used for the hourly values to accommodate the variability of the sample sizes between the three depths. Also, the Mann-Whitney Rank Sum Test was used to determine if any of the three point values at monitoring station 21 are representative of the vertically averaged DO concentration.

The statistical testing calculations were performed using SigmaStat Version 2.0 for Windows 95, NT, and 3.1. Details of the testing procedures and the output formats are presented in detail in the report of the Phase II portion of this study (Butts et al., 1999).

RESULTS

All the DO data were subjected to QA/QC adjustments. The adjusted DO data for all the monitor outputs is available on disk in a Microsoft Access 97 database format. The discrete hourly DO, temperature, pH, and specific conductance values also are available on disk upon request. Temperature, pH, specific conductance, and nitrogen data are presented as generalized summaries in this report.

Continuous Monitoring DO

Table 7 presents a chronological review of the installation and exchange schedule. During 1996, as noted previously, all units were initially installed on March 13, 14, or 15, and all units were removed on November 20. On five occasions, data were lost because the monitors were damaged by either barges or vandalism; for four of those situations, all or part of the previous period's data were lost. At monitoring station 12 on April 17, 1996, vandalism prevented an exchange, although the existing unit was recovered with good data. Repair and security improvements could not be made until April 23, 1996, which resulted in about a six-day loss of data.

The start ups of the two SEPA station evaluation events conducted during 1996, as part of the Phase II study, are clearly delineated by the removal of monitors without exchanges at several locations between July 30 and September 26. A shortage of monitors occurred during this period because two units instead of only one were installed in the intakes of SEPA stations 3, 4, and 5. This was done on the theory that the total loss of data at sites, such as monitoring stations 1, 2, 21 mid-depth (m), and 21 bottom (b), was minor relative to the potential total loss of data at the intakes of SEPA stations 3, 4, and 5 during Phase II operations. The duplicate installations are denoted as \bar{X} in table 7.

Table 8 presents periods in which useable data were collected by station, including the dates the first monitor was installed (03/13/1996, 1200) and the last monitor was retrieved (11/20/1996, 1400). Percentages of the completeness of the data coverage varies from a low 65 percent at monitoring station 2 to a high of 100 percent at monitoring station 9. The relatively low percentages at stations 1, 2, 21m, and 21b are due primarily to the removal of units at these stations for use during the Phase II portion of this study. Without this removal, and assuming full data recovery, the completeness percentages would have been increased from 70 to 80 percent at monitoring station 1, from 65 to 85 percent at monitoring station 2, from 77 to 86 percent at monitoring station 21m, and from 73 to 82 percent at monitoring station 21b. Similarly, assuming the units had not been destroyed by barges and full data recovery, the completeness percentages would have increased from 81 to 95 percent at monitoring station 7, from 85 to 99 percent at monitoring station 10, and from 84 to 92 percent at monitoring station 13.

Overall during the study, the total useable data recovery from all continuous monitoring sites equaled 96,468 unit-hours. This represents approximately 78 percent of

the projected total. Eliminating the advertent removal of the units for use in the Phase II study and the inadvertent destruction to units by barges, this percentage would have increased to 82 percent. In other words, the reliability of the monitors used throughout Phase I applications appears to be about 82 percent. This reliability percentage includes the exclusive use of the older DataSonde I units during the initial stages of this Phase I study and during the Phase II study. The exclusive use of the YSI 6000s probably would have raised the reliability factor above 90 percent, a value that was achieved during Phase II.

Temporal (Station) Profiles

Table 9 presents the total number of usable hourly DO measurements recorded at each station during the study. Many more readings were recorded but were clearly erroneous and were not included. This is the context in which the term “usable” is used in table 9. It includes those data points inclusive within the periodic intervals in table 6. Temporal plots of the DO values for each station are given in appendix B; missing data is indicated by “MD”.

The DO and temperature results from continuous monitoring at all stations are summarized, numerically, with basic descriptive statistics in table 10. The results are provided for the overall study period and the six subperiods. For the entire study period, March 3-November 20, 1996, the mean DO concentrations were greater than the IEPA stream standards. The periodic data presented in table 10 has been rearranged and presented by station as shown in table 11. With the exception of monitoring station 1, at times hourly DO values were less than the stream standards. During warm-weather, low-flow conditions for July 7-September 25, 1996 (period 4), the mean DO values remained greater than the stream standards while the hourly values were less than the stream standards, except for monitoring stations 1 (RM 328.10) and 9 (RM 318.08).

Longitudinal Profiles

Longitudinal profiles were developed for the mean DO concentrations and the mean DO concentrations minus two standard deviations ($\bar{X}-2$ S.D.) for the periods in table 6. Additionally, similar profiles were developed for April 19-October 31, 1996, the time during which all the SEPA stations were in operation. Plots of those profiles are shown on figures 23-30. For normally distributed data, 95 percent of all values fall between $\bar{X}\pm 2$ S.D. Consequently, the $\bar{X}-2$ S.D. line represents concentrations that probably occur less than 2.5 percent of the time on an hourly basis.

The $\bar{X}-2$ S.D. profile was greater than the DO standard for March 16-April 18, 1996 (figure 23), and November 1-19, 1996 (figure 28). However, during the remaining periods, including the one encompassing the full extent of the SEPA station operation (04/19–10/31/1996, figure 30), the $\bar{X}-2$ S.D. profile was less than the DO standard at various intervals. Along the Cal-Sag Channel and its associated waterways, the DO values were less than $\bar{X}-2$ S.D. for intermittently short reaches, whereas, $\bar{X}-2$ S.D. was

less than the standard along the entire study reach of the Chicago Sanitary and Ship Canal (figures 24-27). As shown on figures 25 and 26, the mean DO profile was less than the 4.0 mg/L DO standard along the extreme lower end of the Chicago Sanitary and Ship Canal. This means that, in a short reach along the lower segment of the canal, hourly DO levels were less than the standard at least 50 percent of the time.

Other Parameters

The continuous monitors were equipped with probes to measure specific conductance and pH in concert with DO and temperature. Although the measurements of these two parameters were not mandated as part of this study, they were included. Only a moderate amount of additional effort was expended to include specific conductance and pH, and potentially useful information was produced. The raw data are available on computer disks and are summarized in appendix C in a reduced form using descriptive statistics. The raw nitrogen data also are available on computer disk and are summarized in appendix C using descriptive statistics.

The most significant aspect of this data is the wide variation shown in specific conductance. Lake Michigan water and discretionary diversion have a major affect on specific conductance levels over a year. Note from appendix C that, during period 1, monitoring stations 1 and 2 had low specific conductance values compared to all the stations below the O'Brien Lock and Dam. Apparently, the specific conductance of Lake Michigan water normally ranges between 0.30 and 0.50 mS/cm; whereas, the specific conductance of Cal-Sag Channel water runs as high as 1.50 mS/cm. During periods 4 and 5, when discretionary diversion was highest, Cal-Sag Channel and Chicago Sanitary and Ship Canal water specific conductance levels are reduced to values ranging from 0.23 to 1.10 mS/cm.

Lake Michigan water, used for discretionary diversion, appears to have a less pronounced affect on pH downstream of the O'Brien Lock and Dam than it does on specific conductance. However, this affect is discernible. Before diversion, pH values ranged between 7.64 and 7.86 at monitoring station 1 (RM 328.10) above the dam and between 6.92 and 7.62 at the intake of SEPA station 5 (RM 303.63). During peak diversion, from July 4-October 31, 1996, the pH range for monitoring stations 1 and 15 were 7.42-8.33 and 6.11 and 7.62, respectively.

Cross-sectional DO/Temperature

Table 12 summarizes the cross-sectional DO and temperature measurements for all 21 stream locations. The point data are available on computer disk for reference. Fifteen runs were made at all stations except for monitoring stations 7 (RM 320.71), 15 (RM 303.63), 17 (RM 320.56), and 20 (RM 295.34) at which 14 runs were made and stations 8 (RM 318.51) and 16 (RM 304.69) at which 13 runs were made.

At monitoring station 10 (RM 317.62), two complete cross-sectional measurements were made on July 24—one during the morning and the other during mid-afternoon. The objective was to determine if primary productivity changes the cross-sectional DO profile significantly from morning to afternoon during warm sunny conditions. During this particular situation, the effect appeared minimal because the morning mean DO value was 3.90 mg/L, compared to an afternoon mean of 4.25 mg/L (table 12), a difference of only 0.35 mg/L.

Table 12 presents the cross-sectional data summarized by station. The mean DO and temperature values in table 12 were rearranged in terms of longitudinal profiling by date and are presented in table 13. Table 13 shows how the mean cross-sectional DO sag curves varied in magnitude on various dates throughout the study period. The lowest DO sag curve extending from RM 328.10 to RM 291.20 occurred on June 19, 1996. On this date, the DO levels dropped below 3.0 mg/L for all stations downstream of station 11 (RM 316.00) except at monitoring station 16 (RM 304.69), at which the transect average was 3.53 mg/L. No other daily cross-sectional average DO profile came close to the June 19, 1996, low DO conditions. The next lowest overall DO profile occurred on July 24, 1996, when the cross-sectional average DO values below station 11 (RM 316.00) ranged from 3.12 to 3.97 mg/L.

The major purpose for taking cross-sectional measurements was to provide information for statistically relating monitor point values to cross-sectional means. The monitor point values are listed in table 12 for the continuous monitoring sites. Overall, 317 cross-sectional measurements were made. The correlations between cross-sectional means and the continuous monitor point values could be more expeditiously derived for such a large number of data sets if the simple means could be used in lieu of weighted means in the statistical computations. Consequently, the possibility of using simple means was explored by selecting ten transects, displaying the most DO variability, for constructing isopleths for use in computing weighted means. Appendix D presents these cross sections, with resultant DO isoplethic construction. Table 14 presents the locations, dates, and unweighted and areal-weighted means. Note, that monitoring stations 6, at the intake of SEPA station 2 (RM 321.32), and 10, immediately below the SEPA station 3 outfall (RM 317.62), accounted for half of the values—two at monitoring station 6 and three at monitoring station 10.

Table 14b presents the results of a paired *t*-test used to determine if the mean differences between the paired DO values are statistically significant. The test indicated they are equal at a 95 percent confidence level because the computed *t*-value is significantly less than the theoretical value. Consequently, the unweighted mean cross-sectional profiles were used to determine the relationships between the monitor readings recorded during the time interval of the transect measurements.

The paired *t*-test was used to determine if the assumption can be made that the monitor readings represent cross-sectional means for each station. Table 15 summarizes the results. At the 95 percent confidence interval, the monitor point readings appear to

represent the cross-sectional means at 12 of the 14 sites. The two sites at which this assumption appears invalid are at monitoring stations 10 and 13. This is not surprising in that both stations are located immediately below SEPA station discharges. Monitoring station 10 is approximately 2,000 feet below the SEPA station 3 outfall (table 2), and monitoring station 13 is approximately 4,000 feet below the SEPA station 4 outfall (table 2). More than 4,000 feet of channel length appears to be needed to effect complete mixing of SEPA stations 3 and 4 discharges. Monitoring station 10 is on the opposite side of SEPA station 3 (figure 16f), and monitoring station 13 and SEPA station 4 are on the same side (figure 16h).

A special explanation is needed for the comparison between the monitor “point” value and the “cross-sectional” value presented for the Lockport Lock and Dam (monitoring station 21) in table 12. The monitor value is not a “point” value, and the cross-sectional value is not a cross-sectional value. The Lockport monitor value in table 15 (monitoring station 21) is the mean of the near surface, “mid-depth”, and bottom monitor values, and the cross-sectional value is the mean of readings taken at 2-foot intervals on the vertical.

A Kruskal-Wallis one-way ANOVA test was performed on the data generated by the three monitors at Lockport (monitoring station 21) to determine if the assumption could be made that the mean DO values produced by all three monitors over common time intervals are equal. The results of this test are presented in table 16. The nonparametric ANOVA test was performed because the data failed the normality test. The results of the test indicate that the three monitor locations produced different results during the study period (table 16). Consequently, a single location may not be representative of the vertical mean, although the mean of the three monitor locations proved to be representative. Correlation and linear regression statistics were used to ascertain which singular location best represents the vertical mean. Fourteen sets of data common to all three continuous monitoring points were available. The vertical means are given for monitoring station 21 in table 12. The results of the statistical testing are as follows:

Statistical Analysis of Vertically Placed Monitors at Lockport, Monitoring Station 21

<i>Location</i>	<i>Correlation coefficient (r)</i>	<i>r²</i>	<i>Standard error of estimate</i>	<i>Y-axis intercept</i>	<i>Independent variable coefficient</i>
near surface	0.966	0.933	0.370	0.198	0.950
mid-depth	0.947	0.897	0.463	0.600	0.818
bottom	0.938	0.880	0.500	0.692	0.834

All three locations in the vertical would suffice for estimating the vertical mean as evidenced by the high coefficient of variance (r^2) values. The r^2 values represent the percentage of variability in the dependent variable, which can be explained by the

independent variable. The variability in near surface, mid-depth, and bottom DO explain 93.3, 89.7, and 88.0 percent of the variability in the mean vertical DO, respectively. Fortunately, the near surface position provides the best estimate. Actually, the correlation is so good that it could be assumed to represent the vertical mean DO without introducing a great deal of error in the estimate. However, for more accurate estimates, the statistically derived surface regression equation should be used. Mathematically it can be written as:

$$V = 0.950S + 0.198 \tag{6}$$

where:

V = mean vertical DO (mg/L)

S = surface DO (mg/L)

0.198 = y-axis intercept

A Kruskal-Wallis one-way ANOVA test was performed on 46,226 water temperature measurements that were temporally common for the three Lockport monitors. The median values for the near surface, “mid depth”, and bottom were 18.45, 18.51, 18.52°C, respectively. Statistically, no differences appeared to exist at the 5 percent level of significance between these averages. This tends to eliminate the possibility that density currents could affect the DO and other water quality parameters at the Lockport vertically measured station.

DO Probability Distributions

Appendices E and F, respectively, give the hourly and daily mean FDC developed for the seasonal study periods. Percentage-DO relationships relative to specific DO concentrations derived using FDC and z-T statistical procedures are presented in tables 17 and 18, respectively. The DO standard applicable to each monitoring site also is listed. Generally, only slight differences exist between the FDC and z-T results.

Readily evident is the fact that monitoring station 16, in the Chicago Sanitary and Ship Canal, which is 1.1 miles above the mouth of the Cal-Sag Channel and free of influence from all SEPA stations, had far higher percentages of DO values below a specified concentration than any other station. This is best demonstrated by the rearrangement of some of the 3.0 mg/L DO data in table 17 as shown in table 19. During period 3, 4.9 percent of the DO values were below 3.0 mg/L at monitoring station 15, the intake of SEPA station 5, on the Cal-Sag Channel; but at monitoring station 16, the comparable station on the Chicago Sanitary and Ship Canal, the percentage was 13.3, almost three times greater.

This example illustrates relative conditions between the Chicago Sanitary and Ship Canal near its juncture with the Cal-Sag Channel and DO conditions at critical locations in the vicinity of SEPA stations 3, 4, and 5 along the lower Cal-Sag Channel. This information is not presented in reference to stream DO standards. Irrespective of

whether or not DO values are less than a given standard is not relevant to these results. It merely shows that SEPA stations 3, 4, and 5 are significantly improving DO conditions below their respective outfalls, including those at monitoring station 17 (RM 302.56) on the Chicago Sanitary and Ship Canal 1.03 miles below SEPA station 5.

Monitoring stations 12 (RM 311.55), 13 (RM 310.70), 9 (RM 318.08), and 10 (RM 317.62) represent DO values for monitoring stations above and below SEPA stations 4 and 3. The results above and below SEPA station 3 for period 4 (07/04-09/25/1996) are somewhat misleading. The downstream increase in the percentage at monitoring station 10 is due principally to a lack of mixing combined with the fact that this station is located along the shoreline opposite the SEPA station outfall (figure 16f). Complete mixing does not occur at any of the three monitoring stations located immediately below SEPA stations 3, 4, and 5. This fact is central to the discussion that follows.

DISCUSSION

To facilitate the following discussion, the IEPA stream-segment DO standards in the Probability Analyses section of this report and those standards specific to each SEPA station intake are:

Stream Dissolved Oxygen (DO) Water Quality Standards for Study Area

<i>Location</i>	<i>River mile</i>	<i>Minimum DO standard (mg/L)</i>
SEPA station 1	328.1	5.0
Calumet River	333.2-326.6	5.0
SEPA station 2	321.3	4.0
Little Calumet River	326.6-319.7	4.0
SEPA station 3	318.1	3.0
Cal-Sag Channel	319.7-303.3	3.0
SEPA station 4	311.6	3.0
SEPA station 5	303.6	3.0
Chicago Sanitary and Ship Canal	303.3-291.2	4.0

Table 20 summarizes the results of this study in terms of DO concentration, and table 21 summarizes the results in terms of the percent of time the DO concentration was less than the standard at each SEPA station intake. Only SEPA station intake monitoring station data is presented because these values best reflect the in-stream effects of SEPA station operation. The results for monitoring stations immediately downstream of each SEPA station are not presented for reasons outlined in the Results section of this report (i.e., incomplete mixing at these stations). The significance of this factor will be further expanded upon in this discussion. The percentages in table 21 are averages of the FDC values in table 17 and the z-T values in table 18.

Table 20 shows that on an actual basis the SEPA station 1 intake DO values were never observed to be less than the minimum standard of 5.0 mg/L. Statistically, however, table 21 indicates that a slight probability exists in which the DO at SEPA station 1 could fall below the standard approximately 0.47 percent of the time (28 hours) for conditions similar to those experienced during the entire study period (03/16-11/19/1996).

Conditions at the intake of SEPA station 2 appeared to be less favorable than those at the other SEPA stations. This should not be interpreted as a failure of SEPA station 1 to function properly. It is not, and the details concerning these results will be discussed later.

The intake DO values at SEPA station 3 essentially remained above the DO standard during the entire study period, except for a brief time during period 3 (05/31-

07/03/1996). During this time a minimum DO of 2.48 mg/L occurred (table 20), and the DO values were less than the standard only 1.53 percent of the time (12 hours). These good results, however, should not be attributed in any way to any upstream DO input from SEPA station 2. Reasons for this will be presented and discussed later.

Essentially intake DO at SEPA station 4 was less than the standard of 3.0 mg/L during periods 2 (04/19-05/30/1996), 3 (05/31-07/03/1996), and 4 (07/04-09/25/1996). During period 3, an extremely low DO of 0.92 mg/L was recorded (table 20). However, such low values at this location rarely occurred. The probability of such low values occurring during conditions exemplified by period 3 at SEPA station 4 is less than 0.07 percent (tables 17 and 18), or less than one hour. The possibility of the DO falling below 3.0 mg/L at this location during period 3 is only 4.14 percent (table 21), or approximately 34 hours. During the entire study period, the probability of the DO falling below 3.0 mg/L is only 1.45 percent (table 21), or approximately 87 hours. These good results can be directly attributed to the operation of SEPA station 3, as will be shown and discussed later.

At the intake of SEPA station 5, the DO values were essentially less than the standard of 3.0 mg/L only during periods 3 and 4 (table 21). For periods 3 and 4 the DO values were less than the standard 4.59 and 3.21 percent of the time, respectively. The combined number of hours during which such conditions persisted was 102. These are respectable figures, and the success at this location can be attributed to the upstream DO inputs from SEPA stations 3 and 4. This will be documented and discussed later.

The in-stream DO study produced two important results. One is that the SEPA stations, particularly stations 3, 4, and 5, are fulfilling the intended function of maintaining stream DO standards in the Calumet and Little Calumet Rivers and in the Cal-Sag Channel. The second is that DO levels less than the DO standard frequently are observed in the Chicago Sanitary and Ship Canal in a reach beginning above its juncture with the Cal-Sag Channel to the Lockport Lock and Dam. Continuous hourly monitoring was conducted at four sites within this reach. A summary of the percent of times and number of hours during which the DO concentrations were less than 4.0 mg/L, the DO standard, is as follows:

**Period of Time that Dissolved Oxygen (DO) Concentrations Were Below
the Standard at Monitoring Stations on the Chicago Sanitary and Ship Canal
during the Entire Study**

<i>Monitoring station</i>	<i>River mile</i>	<i>Concentrations less than DO standard</i>	
		<i>Percent of time</i>	<i>Number of hours</i>
16	304.69	23.32	1394
17	302.56	12.52	748
18	299.55	13.27	793
21 near surface	231.20	32.76	1958
21 mid-depth		32.52	1943
21 bottom		28.50	1703

Note: These results were derived using the FDC statistical method.

The results in this tabulation indicate that SEPA station 5 does a good job of reducing the frequency at which the DO values in the Chicago Sanitary and Ship Canal are less than the DO standard for at least 4 miles downstream of SEPA station 5 (RM 303.57). This observation is clearly supported by data generated during study periods 3 and 4, as illustrated by figures 25 and 26. These two figures represent critical warm-weather, low-flow conditions. Note from figure 25 that the mean DO concentration at monitoring station 17 (RM 302.56) is significantly higher than the mean DO at monitoring station 16 (RM 304.69). During period 4, the difference in mean DO values between monitoring stations 16 and 17 is less than that for period 3, but the DO at monitoring station 17 is increased to values above the DO values at monitoring station 16 on the average, and the supplement of DO from SEPA station 5 appears to prevent a rapid deterioration in DO below the junction of the two waterways.

The SEPA stations 1 and 2 appear to have minimal effects on improving in-stream DO levels. The SEPA station 1 is poorly located longitudinally along the waterway. Its intake is in an area of high ambient in-stream DO concentrations (table 20). At monitoring station 1, during critical periods 3 and 4, a 6.0 mg/L DO level was exceeded 100 percent of the time during period 3 and 95 percent of the time during period 4 (table 18). The 5.0 mg/L DO level was exceeded virtually 100 percent of the time for both periods 3 and 4 (table 18). The mean water temperature during period 4 was approximately 23°C (table 10). The DO saturation at 23°C is approximately 8.2 mg/L at the elevation of SEPA station 1. Consequently, a 6.0 mg/L DO represents a saturation of 73 percent, and 5.0 mg/L DO represents 69 percent saturation. These are relatively high values for that time of year.

A slight chance exists (2.5 percent, figure 26) that the mean DO concentration for period 4 could be less than the 5.0 mg/L standard applicable between SEPA station 1 and the O'Brien Lock and Dam. Butts et al. (1999) show that SEPA station 1 produces DO outputs of 100 percent saturation when operating normally with one pump. The

effectiveness of a one-pump operation is not fully known and could be questioned. The question could be asked, “Would completely shutting down the station increase the frequency at which the in-stream DO would fall below the DO standard?” In contrast, another question could be asked, “Would using more than one pump at certain times prevent the DO from falling to values less than the standard some or all the time?” These questions cannot be answered by this study. The DO levels were less than the 5.0 mg/L DO standard approximately 7.48 percent of the time in reference to the FDC data (table 17) or 2.62 percent of the time in reference to the z-T data (table 18) for the 2016 hours of period 4.

The SEPA station 2 appears to be no more effective than SEPA station 1 in increasing waterway DO levels. The DO profiles presented in figures 25 and 26 demonstrate this. Note that the DO profiles between SEPA station 1 and continuous monitoring station 7, immediately below SEPA station 2, show a continuous drop or sag without any evidence of immediate increases in DO levels at the stations or significant reductions in the slope of the DO profiles below the stations. This can be attributed to natural processes in DO consumption during warm weather associated with long travel times in this reach of 7.39 river miles. Possible contributions could come from periodic and/or fluctuating flows from Lake Calumet and the Grand Calumet River and operations at the O’Brien Lock and Dam. Also, the natural characteristics of the large, shallow, bay-like area in which SEPA station 2 is located and at which the Calumet Wastewater Treatment Plant effluent discharges readily affect DO concentrations.

The aeration potential at SEPA station 2 is limited because of low pumping capacity (table 1), and its location on a baylike area immediately below the Calumet Water Reclamation Plant outfall (figure 16c). The reaeration efficiency of the SEPA station is high, but its DO output load in terms of pounds per day of oxygen is low due to its limited pumping capacity. The baylike area receives a significant portion of the treatment plant effluent that contains DO concentrations of 5 mg/L or greater (documented by field measurements during this study), it is shallow (less than 3 feet in most areas), the bottom supports prolific growth of submerged and emergent aquatic vegetation, and stream flow is not always in a downstream direction due to unusual circulatory patterns caused by wind, natural eddy currents, wastewater treatment flow, and turning of barges around the “dogleg” bend (figure 16c). Furthermore, benthic sediments are loose and flocculent and are easily suspended by wind and barge-induced wave action. This causes sudden and often dramatic drops in DO in the baylike area. Such occurrences were documented several times during this study while conducting field measurements.

All these factors contribute to some degree to the sharp peaks and valleys exhibited in the temporal DO curves recorded at the SEPA station 2 intake (monitoring station 6) as depicted in appendix B. During the cross-sectional measurements, the outfall of SEPA station 2 was observed being pushed upstream, resulting in recycling through the SEPA station. Slight wind shifts were observed to change point readings near the intake by as much as 4 or 5 mg/L DO in less than five minutes.

In contrast to the lack of discernible improvements in in-stream DO values in the reaches below SEPA stations 1 and 2, improvements in in-stream DO values below SEPA stations 3, 4, and 5 were evident, as indicated by the positive changes in the mean DO profiles below each of these stations, especially during the critical warm-weather, low-flow periods 3 and 4. As shown on figures 25 and 26, these improvements are evidenced somewhat by increases in the DO concentrations at the continuous monitoring stations immediately below SEPA stations 3, 4, and 5, and/or by flatter DO profiles or DO-sag curves for the reaches between these aeration stations.

If mixing of the SEPA aerated water with ambient in-stream water had been more complete at the continuous monitoring stations immediately below each SEPA station, the increases in DO at monitoring stations 10, 13, and 17, below SEPA stations 3, 4, and 5, respectively, would have been more pronounced when plotted. For example, at monitoring station 10 on July 24, 1996, the mean DO was 4.58 mg/L within that portion of the cross section 40 feet from the right bank looking downstream (appendix D). The mean DO levels for the remaining cross-sectional area and the total cross-sectional area were 3.35 mg/L (appendix D) and 3.90 mg/L (table 12), respectively. The theoretical, completely mixed mean for a transect located at the outfall is 4.47 mg/L as compared to the cross-sectional mean of 3.35 mg/L for the transect at the intake of SEPA station 3 (station 9, table 12). The 4.47 mg/L value was derived via a mass balance computation. The outfall DO concentration was 8.48 mg/L with two pumps operating, which resulted in a SEPA station flow equal to 240 cubic feet per second (cfs). The in-stream flow above the SEPA station was 1102 cfs.

This example illustrates an important point and an important concept. The point is that the immediate effects of SEPA stations 3, 4, and 5 on in-stream DO at or immediately below each outfall is much more dramatic than can be measured by continuous or manual monitoring and illustrated using DO profiles. The concept is that simple subtraction can be used to estimate what the theoretical DO-sag curve value would be at the intake of the next downstream SEPA station in the absence of SEPA station operation. For example, neglecting natural in-stream reaeration, the estimated mean cross-sectional DO at monitoring station 12 (SEPA station 4 intake) would be $[3.35 - (4.47 - 3.46)]$ or 2.34 mg/L, in the absence of SEPA station 3, compared to the observed July 24, 1996, value of 3.46 mg/L (table 12). In other words, even with SEPA station operation, the DO profile continues to sag at approximately its normal rate. The sag starts at 4.47 mg/L, with two pumps operating at SEPA station 3, instead of 3.35 mg/L; this prevents the DO from being less than the DO standard of 3.0 mg/L.

The actual in-stream DO usage due to ambient biochemical oxygen demand (BOD) and SOD is a little greater than $4.47 - 3.46$ or 1.01 mg/L, as some natural reaeration has to be factored into the total usage computation to obtain a precise value. The BOD load is not reduced in the channel water routed through SEPA stations (Butts et al., 1999) and ambient in-stream SOD continues to deplete in-stream DO irrespective of SEPA station operation.

Similarly, a good estimate of what the DO concentration would have been near the mouth of the Cal-Sag Channel, in the absence of SEPA stations 3 and 4 on July 24, 1996, can be made by subtracting the combined DO drops between SEPA stations 3 and 4 and SEPA stations 4 and 5 from the 3.35 mg/L mean cross-sectional DO recorded at the SEPA station 3 intake. On July 24, 1996, the SEPA station 4 outfall DO was 8.42 mg/L with two pumps operating (240 cfs). The mean cross-sectional values at the intakes of SEPA stations 4 and 5 were 3.46 and 3.78 mg/L (table 12), respectively. The computed, mass balance, completely mixed DO value of the SEPA station 4 transect is 4.54 mg/L. Consequently, the DO drop between SEPA stations 4 and 5 is 4.54 - 3.78 or 0.76 mg/L. The total drop in DO between SEPA stations 3 and 5 would be 1.01 + 0.76 or 1.77 mg/L. Therefore, in the absence of SEPA stations 3 and 4, the DO at the mouth of the Cal-Sag Channel would have been approximately 3.35 - 1.77 or 1.58 mg/L. The actual value would be somewhat, but not significantly, greater than 1.58 mg/L due to DO input from natural in-stream aeration.

The operation of SEPA stations 3 and 4 appear to be doing a good job of preventing the DO levels from becoming less than the DO standard during critical warm-weather, low-flow conditions as the following shows:

Percent of Time Mean Cross-sectional DO Exceeds DO Standard of 3.0 mg/L

<i>SEPA station intake</i>	<i>Period 3</i>		<i>Period 4</i>	
	<i>FDC</i>	<i>z-T</i>	<i>FDC</i>	<i>z-T</i>
4	96	96	92	99
5	95	96	96	98

These results are very positive and show SEPA stations 3 and 4 successfully prevent DO levels from becoming less than the DO standard for the Cal-Sag Channel. This is a testament to: (1) excellent SEPA station designs that produce 90 to 100 percent DO saturation output, (2) proper engineering design relative to longitudinal placement of each SEPA station along the waterway, and (3) excellent operation and management of each SEPA station.

The DO values below SEPA station 3 were less than the DO standard of 3.0 mg/L on one date (6/19/1996), during which manual cross-sectional DO/temperature measurements were made (table 13). These low DO values, plus the fact that only two pumps were in operation at the time at SEPA stations 3 and 4, permitted making evaluations relative to increasing DO concentrations above the stream standard by increasing pumping rates at SEPA stations 3 and 4. The results of these evaluations are summarized as:

**Evaluation of Mean Cross-sectional DO Values at SEPA Station Intakes
under Various Pump Operations and Scenarios**

<i>Scenario</i>	<i>Number of pumps operating at SEPA station</i>		<i>Mean cross-sectional DO (mg/L) at intake of SEPA station</i>		
	<i>3</i>	<i>4</i>	<i>3</i>	<i>4</i>	<i>5</i>
1	2	2	3.83	2.47	1.97
2	3	2	3.83	3.18	2.48
3	3	3	3.83	3.18	3.28

Scenario 1 represents observed ambient conditions; the experimental design for this period specified that only two pumps were to be operated at SEPA stations 3 and 4. A three-pump operation at SEPA station 3 probably would have increased the mean cross-sectional DO significantly above 3.18 mg/L at SEPA station 4, but to maintain such a level at SEPA station 5, three pumps would have had to be used at SEPA station 4. The tabular FDC and z-T percentages presented here may have been greater if pumping rates had not been controlled as per experimental design specifications (table 4). The pumping rate flexibility of the SEPA stations appear to be more than adequate to prevent DO levels from being less than the standard within the Cal-Sag Channel under a wide range of conditions. However, consideration should be given to operating SEPA stations 3 and 4 at pumping rates in excess of those needed to solely maintain the DO standards of the Cal-Sag Channel. Pumping rates beyond this minimal requirement appear to significantly improve in-stream DO values as far downstream as Lockport. Information in support of this will be presented and discussed in detail later.

Analyzing the effects of SEPA station 5 on in-stream DO is more complicated, and the results are less determinant, than those just presented for SEPA stations 3 and 4. Complicating factors involve having to: (1) split SEPA station 5 outfall flows, (2) combine two waterway flows, and (3) analyze downstream conditions without the reach terminating at a SEPA station. Illustrative analyses will be presented for various scenarios for the two dates, July 24 and June 19, 1996, used to examine the influences of SEPA stations 3 and 4 on in-stream DO along the lower reaches of the Cal-Sag Channel.

The computed, completely mixed DO in the Chicago Sanitary and Ship Canal immediately below SEPA station 5 was 3.98 mg/L for the July 24, 1996, conditions. It was derived using the following criteria: ambient DO values at monitoring stations 15 and 16 are 3.78 and 3.82 mg/L, respectively; ambient outfall DO values are 8.30 mg/L; and outfall, Chicago Sanitary and Ship Canal, and Cal-Sag Channel flows are 116, 1890, and 1102 cfs, respectively. The Chicago Sanitary and Ship Canal DO is raised 0.16 mg/L (3.98 – 3.82) with only one pump operating as was specified by the experimental design criteria (table 4). Completely mixed DO concentrations in the Chicago Sanitary and Ship Canal immediately downstream of SEPA station 5 for July 24, 1996, conditions are presented below for various pumping rates:

**Completely Mixed DO Concentrations on the Chicago Sanitary and Ship Canal
Immediately below SEPA Station 5 and at Lockport, July 24, 1996**

<i>Operating pumps at SEPA station 5</i>	<i>DO (mg/L)</i>	
	<i>Completely mixed</i>	<i>Lockport</i>
0	3.81	2.95
1 (ambient)	3.98	3.12
2	4.15	3.29
3	4.33	3.47
4	4.50	3.64
5	4.68	3.82

These results indicate that, for hydraulic/hydrologic, biological/biochemical, and weather-related water conditions which existed on July 24, 1996, the DO concentration at Lockport would persistently be less than the DO standard of 4.0 mg/L, although it could be raised significantly by maximizing SEPA station pumping rates.

The question that arises from these results is whether the SEPA system, as a “whole”, could have been operated to raise the DO levels at Lockport to values that would not be less than the DO standard during various time periods when they were below the standard. An evaluation was made for July 24, 1996, conditions assuming three-pump operations at SEPA stations 3 and 4 and a four-pump operation at SEPA station 5. Using three pumps at SEPA stations 3 and 4 in combination with three or four pumps at SEPA station 5 appears to benefit in-stream DO conditions throughout the Chicago Sanitary and Ship Canal below SEPA station 5.

Mass balance computations indicate that, if three pumps were used at SEPA stations 3 and 4 in concert with four at SEPA station 5, for July 24, 1996, conditions, the DO at Lockport probably would have improved to approximately 3.85 mg/L from 3.12 mg/L recorded on July 24, 1996 (table 13). Although 3.85 mg/L is less than the DO standard of 4.0 mg/L, it is significantly better than that observed. The mean cross-sectional DO in the Chicago Sanitary and Ship Canal above SEPA station 5 would have had to be at least 4.05 mg/L with the institution of maximum pumping at the SEPA stations to prevent DO levels from becoming less than the standard at Lockport. The 4.05 mg/L value is 0.23 mg/L greater than that recorded on July 24, 1996. Improvements or increases in DO levels in the Chicago Sanitary and Ship Canal immediately above SEPA station 5 that needed to maintain DO levels at Lockport (which are not less than the standard) are often much greater than 0.23 mg/L computed for July 24, 1996, conditions. An extreme case for conditions observed on June 19, 1996, is presented to illustrate this fact.

On June 19, 1996, the mean vertical DO at Lockport (monitoring station 21) was 1.00 mg/L. Two pumps were being operated at SEPA stations 3 and 4 and three pumps were being operated at SEPA station 5 (table 4). The completely mixed DO values in the

Chicago Sanitary and Ship Canal below SEPA station 5 and at Lockport for ambient conditions, as well as other pumping rates, are presented:

**Completely Mixed DO Concentrations on Chicago Sanitary and Ship Canal
Immediately below SEPA Station 5 and at Lockport, June 19, 1996**

Scenario	Operating pumps at SEPA station			Mean cross-sectional DO (mg/L)	
	3	4	5	Immediately below SEPA station 5	Lockport
1	2	2	1	3.34	0.53
2 (ambient)	2	2	2	3.59	0.77
3	2	2	3	3.81	1.00
4	2	2	4	4.04	1.23
5	3	3	1	3.64	0.83
6	3	3	2	3.83	1.02
7	3	3	3	4.02	1.21
8	3	3	4	4.20	1.39

Note that, under the June 19 extreme conditions, three-pump operations at SEPA stations 3 and 4 and a four-pump operation at SEPA station 5 produced a mean DO at Lockport that is considerably less than the 4.0 mg/L DO standard. The June 19, 1996, conditions may appear to be extreme, but similar “extremes” often were recorded via continuous monitoring as illustrated by the DO plots for monitoring stations 21t (near surface), 21m (mid-depth), and 21b (bottom) at Lockport (appendix B).

The DO values at Lockport for the warm-weather, low-flow conditions, similar to those encountered during periods 3 and 4 of this study, can be expected to be less than 4.0 mg/L at the frequencies presented:

**Expected Frequency of Hours when DO Would be Less than 4.0 mg/L
Standard DO at Lockport, 1996**

Location on Lockport vertical	Period 3 (5/31-7/03)		Period 4 (7/04-9/25)	
	FDC	z-T	FDC	z-T
Near surface	50.1	57.5	71.7	74.2
Mid-depth	55.7	61.4	69.0	68.1
Bottom	51.0	51.2	51.7	54.4

Note: Percentage values from tables 17 and 18.

The following tabulation presents the mean cross-sectional DO concentrations that would have been needed for various pumping rates at SEPA station 5, with three-pump

operations at SEPA stations 3 and 4, to maintain DO values of 4.0 mg/L at Lockport on June 19 and July 24, 1996. These dates are the only two for which the mean DO at Lockport was less than the DO standard of 4.0 mg/L for the dates when cross-sectional DO measurements were taken.

**DO Required in Chicago Sanitary and Ship Canal above SEPA Station 5 to
Maintain 4.0 mg/L Standard DO at Lockport, 1996**

<i>Operating pumps at SEPA station 5</i>	<i>DO (mg/L) required</i>	
	<i>6/19</i>	<i>7/24</i>
1	7.51	4.70
2	7.26	4.49
3	7.02	4.27
4	6.78	4.05

The ambient mean cross-sectional DO values recorded at monitoring station 16, on the Chicago Sanitary and Ship Canal above SEPA station 5 on June 19 and July 24, 1996, were 3.53 mg/L and 3.82 mg/L, respectively. Both values are well below those needed to achieve a DO level of 4.00 mg/L at Lockport using the full practical pumping capacities of all three SEPA stations.

Similar computations could not be performed using the continuous monitoring data as continuous monitoring of SEPA station outfall DO levels was not routinely done in conjunction with in-stream monitoring. The DO data for the in-stream stations immediately below the SEPA stations cannot be used because they do not include the total DO loads being discharged from the SEPA stations, as discussed earlier, for conditions observed below SEPA station 3 on July 24, 1996. However, the computations presented here clearly indicate that, for conditions similar to those that occurred during this study, supplemental oxygen would be needed in the Chicago Sanitary and Ship Canal above SEPA station 5 (appendix B, monitoring station 16) to maintain DO levels of 4.0 mg/L or greater at Lockport.

Table 22 presents summaries of computed, completely mixed, in-stream mean DO concentrations at the SEPA station outfalls and those measured at cross-sectional stations immediately downstream of each SEPA station. Also, summarized are in-stream cross-sectional means at the SEPA station intakes. This summary highlights several important points germane to this study. First, it shows that each SEPA station has an immediate positive impact on in-stream DO values irrespective of what the mean DO profiles depicted in figures 23-30 show. When the impacts are small, such as at SEPA stations 1 and 2, the positive effects can best be demonstrated using completely mixed values. This is clearly evident for SEPA station 2. The mean downstream value recorded at monitoring station 7 for nine dates was 5.50 mg/L versus a completely mixed value of 6.22 mg/L. The downstream 5.50 mg/L value was significantly less than the SEPA station mean

intake value of 6.08 mg/L, whereas the “mixed value” of 6.22 mg/L was significantly greater.

The positive impacts of SEPA stations 3, 4, and 5 are much more evident than those for SEPA stations 1 and 2, in reference to both the immediate downstream monitoring station results and the computed, completely mixed results. For example, for SEPA station 3, the means for the monitoring station below SEPA station 3 (monitoring station 10) and the computed, “mixed value” are, in order, 0.56 mg/L and 0.86 mg/L greater than the 4.84 mg/L mean intake value.

The drop in the DO values between the SEPA stations and the immediate downstream monitoring stations (2, 7, 10, 13, and 17), as depicted on figures 24-27, are an artifact of location. These drops are not caused by a lack of DO input from the SEPA stations. Of the 20 SEPA station area subprofiles (shown on figures 24-27), 12 exhibit oxygen depletion immediately downstream. This is illusionary and would not appear as such if “completely mixed” values could have been computed and plotted for each period. The fact that an immediate DO sag did not occur during the four scenarios for SEPA station 4 (shown on figures 24-27) should not be interpreted as SEPA station 4 doing a better job or being a more efficient aerator than the other four SEPA stations. It only appears that SEPA station 4 is more efficient because monitoring station 13, located immediately downstream, more closely approximates completely mixed conditions than the other downstream monitoring stations 2, 7, 10, and 17.

Data presented in table 22 reveal many daily situations for which the recorded mean cross-sectional DO values immediately below the SEPA stations are actually lower than the intake values when, in reality, they are not as evidenced by the computed “mixed” values. This is best exemplified by conditions for the intake at SEPA station 2 (monitoring station 6) and downstream monitoring station 7. Of the 11 dates for which all three values are available in table 22, for SEPA station 2, only one exhibited a cross-sectional mean DO at monitoring station 7 which was equal to or greater than that at monitoring station 6. However, the computed, completely mixed values were greater for all 11 dates (table 22) in spite of the fact that the DO load discharged by SEPA station 2 was relatively small.

Although the cross-sectional means below SEPA stations 3 and 4 (monitoring stations 10 and 13, respectively) are generally higher than the intake values, the computed “mixed” values are all greater than those recorded for each date. On a number of dates, the “mixed” values were much greater than the recorded values. For example, below SEPA station 4 on June 19, 1996, the recorded mean cross-sectional DO value was only 2.66 mg/L versus a computed, completely mixed value of 4.27 mg/L. And on September 18, 1996, the mean cross-sectional value recorded at monitoring station 13, below SEPA station 4, was 0.10 mg/L less than the cross-sectional mean recorded at monitoring station 12 (SEPA station 4 intake).

The absolute effects of each station and the relative effects between stations on in-stream DO is demonstrated by the data in table 23. For SEPA stations 2-5, intake DO

values were computed for situations in which the upstream SEPA stations were assumed not operating and compared to ambient conditions. Note that the mean daily intake DO value at SEPA station 3 would have been reduced by only 0.13 mg/L if SEPA station 2 had not been operating; but without SEPA station 3 operating, the mean daily intake DO at SEPA station 4 would have been reduced by 0.86 mg/L. With SEPA stations 1-3 operating, but not SEPA station 4, the mean daily intake DO at SEPA station 5 would have been reduced by 1.08 mg/L. A summary of what the approximate mean DO values of table 23 would have been and their deviations from ambient for conditions without any SEPA station operation is as follows:

**Summary of Projected Mean DO Values at SEPA Station Intakes
with and without SEPA Operation**

<i>Intake at SEPA station</i>	<i>Dissolved oxygen (mg/L)</i>		
	<i>With (ambient)</i>	<i>Without</i>	<i>Difference</i>
2	6.12	5.63	0.49
3	4.86	4.24	0.62
4	4.42	2.94	1.48
5	4.70	2.14	2.56

Although these results are based on only nine dates when manual cross-sectional measurements were taken, they are good indicators of the importance of each station. This summary and the daily results in tables 22 and 23 indicate that, if SEPA stations 1 and 2 were not operated, DO values at the intakes of SEPA stations 2 and 3 probably would not be less than the DO standard of 4.0 mg/L at SEPA station 2 and 3.0 mg/L at SEPA station 3. However, SEPA stations 3 and 4 are needed so that the DO values at the intake of SEPA station 5 are never less than the DO standard of 3.0 mg/L.

CONCLUSIONS

A field study was conducted between March 16 and November 19, 1996, to collect in-stream DO/temperature data to evaluate effects of SEPA station operations on in-stream water quality from waterway RM 328.10 on the Calumet River to RM 291.20 on the Chicago Sanitary and Ship Canal at Lockport. Continuous monitoring stations were established at 14 locations to collect hourly DO/temperature data.

Location of Continuous Monitoring Stations

<i>Description</i>	<i>Waterway</i>	<i>RM</i>
SEPA station 1, intake Norfolk/Western RR	Calumet River	328.10 327.69
SEPA station 2, intake Penn Central RR	Little Calumet River	321.32 320.71
SEPA station 3, intake Baltimore/Ohio RR	Cal-Sag Channel	318.08 317.62
SEPA station 4, intake SW Highway 104th Avenue	Cal-Sag Channel	311.55 310.70 307.15
SEPA station 5, intake Canal at Highway 83	Cal-Sag Channel	303.63 304.69
Canal at power lines Canal at slip No. 2	Chicago Sanitary and Ship Canal	302.56 299.55
Lockport Lock and Dam	Chicago Sanitary and Ship Canal	291.20

The longitudinal locations appeared to be good as large quantities of productive data were generated at each location. However, some initial problems were encountered at a few locations due to barge traffic. Special monitor riggings had to be fabricated and installed, and sampling procedures were instituted to overcome the hazards of barge traffic.

Manual DO/temperature measurements were made on 13 dates either on a cross-sectional or vertical basis at 14 continuous monitoring sites and seven additional locations. Cross-sectional measurements consisted of selecting a number of transverse locations on transects and measuring DO/temperature at selected depths on verticals at these locations. Vertical stations designate locations at which DO/temperature readings were taken at selected depths on only one vertical. The objectives were to: (1) determine relationships between continuous monitoring point and mean cross-sectional DO values, (2) provide supplemental DO/temperature data in long waterway reaches without continuous monitoring stations, and (3) provide data for computing completely mixed in-stream DO concentrations at each SEPA station outfall. For objective 1, the continuous monitoring point DO readings appeared, overall, to approximate the cross-sectional

means. At 12 of 14 continuous monitoring stations, the hypothesis that the continuous monitoring point values and the cross-sectional means are equal proved to be true (95 percent confidence level). The two stations for which this hypothesis was rejected are below SEPA stations 3 (RM 317.62) and 4 (RM 310.70) on transects that are not completely mixed with SEPA station aerated water. These results indicate that continuous monitoring point data can be used to approximate cross-sectional means in the study area. For objective 2, the supplemental data generated between continuous monitoring stations indicated that the DO drops in long reaches are gradual and relatively smooth. This, in turn, indicated that the selection of the continuous monitoring sites was good, i.e., no unusual or critical locations were left unmonitored. For objective 3, the completely mixed, in-stream DO values computed for transects at each SEPA station outfall differed significantly from those measured at cross sections immediately downstream of the outfalls. With few exceptions, the downstream cross-sectional mean DO was significantly less than the computed “completely mixed” value. A good example is the June 19, 1996, results:

Dissolved Oxygen (DO) at SEPA Station Outfall Transects and Below, June 19, 1996

<i>Location</i>	<i>SEPA Station</i>				
	<i>1</i>	<i>2</i>	<i>3</i>	<i>4</i>	<i>5</i>
DO (mg/L) mixed	8.79	5.54	5.25	4.28	3.58
DO (mg/L) below	7.19	4.74	4.24	2.71	2.88

A monitoring site that can, in itself, provide good estimates of the immediate impact that SEPA stations have on supplementing the DO resources of the waterway cannot be selected. The effects can be gauged only by the DO concentrations at the intakes of downstream SEPA stations and at Lockport. At least 4,000 feet apparently are needed to affect complete mixing below a SEPA station.

Evaluations were made of the effectiveness of each SEPA station on raising in-stream DO concentrations. These evaluations were made using the manually recorded cross-sectional measurements and the completely mixed cross-sectional means computed for transects at the outfalls of each SEPA station. In general, the results indicate SEPA stations 1 and 2 raise in-stream DO values very little, and SEPA stations 3, 4, and 5 measurably improve in-stream DO levels. The effectiveness of a SEPA station has to be viewed from two perspectives: in terms of the absolute amount of DO added to the waterway, and in terms of ambient in-stream DO concentrations, i.e., does the in-stream DO need to be supplemented to prevent DO values from becoming less than the standard. The results of analyses addressing these two points for July 2, 1996, data are:

Effectiveness of SEPA Station Operations, July 2, 1996

<i>Condition</i>	<i>DO (mg/L) at SEPA station</i>			
	2	3	4	5
With upstream SEPA operation	6.37	4.28	3.98	5.14
Without upstream SEPA operation	6.36	4.13	2.83	2.16
DO standard	4.00	3.00	3.00	3.00

On July 2, 1996, SEPA station 1 contributed only 0.1 mg/L of DO to the mean cross-sectional DO at the intake of SEPA station 2, and SEPA stations 1 and 2 combined contributed only 0.15 mg/L of DO to the mean cross-sectional DO at the intake of SEPA station 3. Furthermore, in both instances the DO values at these locations would have remained well above the standard if one or both stations had not been operating. The situation below SEPA station 3 is entirely different. Both SEPA stations 3 and 4 generated DO loads that were needed to maintain DO standards. Without SEPA stations 3 and 4 operating, the mean cross-sectional DO at the intake of SEPA station 5 would have been almost 1.0 mg/L less than the standard. This example is typical of daily events as they occurred during this study period. The DO data generated by the continuous monitors support this contention. During the overall study period, the DO standard at the intake of SEPA station 3 was exceeded 99.33 percent of the time. The supplemental oxygen injected at SEPA stations 1 and 2 played an insignificant role in producing this high percentage.

During the study period, SEPA stations 3 and 4 were well managed relative to maintaining at least a 3.0 mg/L DO concentration in the Cal-Sag Channel. During warm-weather, low-flow periods 3 and 4, the DO standard was exceeded approximately 98.1 percent of the time at the intake of SEPA station 4 and 96.5 percent of the time at the intake of SEPA station 5. For the entire study period, the DO standard was exceeded 98.6 percent of the time at the intake of SEPA station 4 and 97.5 percent of the time at the intake of SEPA station 5. These high percentages were achieved without having to routinely operate either SEPA station at full capacity. Three pumps were operated only 1.6 percent of the time at SEPA station 3 and 2.4 percent of the time at SEPA station 4 during the study.

The results of the Phase II part of this study (Butts et al., 1999) showed that SEPA station 5 was a highly efficient aerator. This finding is supported by data derived from this in-stream (Phase I) study. Although SEPA station 5 was operated at less than 50 percent of its maximum pumping capacity of 461.6 cfs 50 percent of the time for critical warm-weather, low-flow conditions from May 31 through September 25, 1996, significant improvements in DO were achieved at least 4 miles downstream on the Chicago Sanitary and Ship Canal. This is illustrated by the following tabulation showing the percent of the time the DO was less than the standard of 4.0 mg/L at three locations below SEPA station 5 compared to the percentage in the Chicago Sanitary and Ship Canal above SEPA station 5.

Percent of Time DO Value Was Less than the 4.0 mg/L Standard DO

<i>Continuous monitoring station description</i>	<i>Chicago Sanitary and Ship Canal (RM)</i>	<i>Miles above/below SEPA station 5</i>	<i>Percent</i>
Highway 83	304.69	1.10 above	59.4
SEPA station 5	303.59	-	-
Power lines	302.56	1.03 below	22.5
Slip No. 2	299.55	4.04 below	25.1
Lockport	291.20	12.39 below	63.0

The combined DO inputs from SEPA stations 3, 4, and 5 did not prevent the DO from being less than 4.0 mg/L in the Chicago Sanitary and Ship Canal. But it significantly reduced the frequency of occurrence at sites at least 4 miles downstream of SEPA station 5 relative to what occurred at the Highway 83 continuous monitoring station 16, above SEPA station 5.

The theoretical effects of operating SEPA stations 3, 4, and 5 at maximum pumping capacities during warm-weather, low-flow conditions was investigated. The results indicated that significant increases in DO levels in the Chicago Sanitary and Ship Canal below SEPA station 5 could be achieved by operating all three SEPA stations at maximum practical pumping rates. This was exemplified by conditions during June 19, 1996. Two pumps were operating at SEPA stations 3 and 4 and three pumps were operating at SEPA station 5. The completely mixed DO at a cross section immediately below SEPA station 5 was computed as 3.81 mg/L, and the observed DO at Lockport was 1.0 mg/L. For three-pump operations at SEPA stations 3 and 4 and a four-pump operation at SEPA station 5, the computed, completely mixed and Lockport DO values were 4.20 mg/L and 1.39 mg/L, respectively. This suggests that, when DO values at Lockport are less than 4.0 mg/L during periods of less than maximum SEPA station pumping rates, significant improvements in DO levels can be achieved below SEPA station 5 by increasing pumping rates at all three SEPA stations. For DO values at Lockport, which are marginally lower than the DO standard (e.g., 3.70 mg/L for two-pump operations at all three stations), maximum pumping rates probably would raise DO levels above 4.0 mg/L. However, for extremely low DO levels at Lockport (as was exemplified for June 19, 1996, conditions) maximum pumping rates alone will not prevent DO levels from falling below 4.0 mg/L and supplemental oxygen would be needed. For example, the in-stream DO in the Chicago Sanitary and Ship Canal above SEPA station 5 would have had to be increased from 3.53 mg/L to 6.78 mg/L to achieve 4.0 mg/L of DO at Lockport if maximum SEPA station pumping had been in effect on June 19, 1996. Similarly, but for less severe conditions on July 24, 1996, the measured DO above SEPA station 5 would have had to be increased from 3.82 mg/L to 4.05 mg/L to maintain a 4.0 mg/L level at Lockport.

The use of continuous monitors can be a highly effective and efficient method of generating data for short-term, intensive studies or for conducting long-term monitoring when used judiciously with a fine-tuned QA/QC program. Approximately an 88 percent data recovery rate was experienced during this study, which is good to excellent considering the magnitude of the study and the obstacles that had to be overcome to make the study successful.

REFERENCES

- Butts, T.A. 1988. *Development of Design Criteria for Sidestream Elevated Pool Aeration Stations*. Illinois State Water Survey Contract Report 452.
- Butts, T.A., D.B. Shackleford, and T.R. Bergerhouse. 1999. *Evaluation of Reaeration Efficiencies of Sidestream Elevated Pool Aeration (SEPA) Stations*. Illinois State Water Survey Contract Report 653.
- Illinois Environmental Protection Agency. 1993. *Title 35: Environmental Protection; Subtitle C: Water Pollution, Chapter I: Pollution Control Board*. State of Illinois Rules and Regulations, Springfield, IL.
- Macaitis, B., J. Variakojis, and B. Kuhl. 1984. *A Planning Feasibility Report on Elevated Pool Aeration Stations*. The Metropolitan Sanitary District of Greater Chicago, Chicago, IL.

TABLES

Table 1. Engineering Design Features of SEPA Stations

No.	Station		Type	Pumps		Weirs			Design maximum flow (cfs)
	Location	River mile		No.	Size	No.	Height (ft)		
						Per weir	Total		
1	Torrence Ave.	328.09	Propeller	4	100 cfs	4	3	12	400
2	127th St.	321.40	Screw	2	84-in.	4	3	12	87
3	Blue Island	318.00	Screw	4	120-in.	3	5	15	479
4	Worth	311.51	Screw	4	120-in.	3	5	15	479
5	Cal-Sag Jct.	303.57	Screw	5	120-in.	4	3	12	577

Table 2. Waterway DO Sampling Stations

Station number	Waterway	Location description	River mile	Sampling type			Rigging design
				Continuous	Cross section	Vertical	
1	CR	SEPA station 1 Intake	328.10	X	X		I
1 Out	CR	SEPA station 1 Outfall	328.00			X	
2	CR	Norfolk/Western RR	327.69	X	X		I
3	CR	O'Brien Lock/Dam	326.62		X		
4	LCR	Michigan Central RR	325.31		X		
5	LCR	Chicago Western RR	322.66		X		
6	LCR	SEPA station 2 Intake	321.32	X	X		III
6 Out	LCR	SEPA station 2 Outfall	321.27			X	
7	LCR	Penn Central RR	320.71	X	X		II
8	CSC	Division St.	318.51		X		
9	CSC	SEPA station 3 Intake	318.08	X	X		II
9 Out	CSC	SEPA station 3 Outfall	318.00			X	
10	CSC	Baltimore/Ohio RR	317.62	X	X		I
11	CSC	Crawford St.	316.00		X		
12	CSC	SEPA station 4 Intake	311.55	X	X		II
12 Out	CSC	SEPA station 4 Outfall	311.49			X	
13	CSC	SW Highway	310.70	X	X		II
14	CSC	104 th Ave.	307.15	X	X		IA
15	CSC	SEPA station 5 Intake	303.63	X	X		IA
15 OutC	CSC	SEPA station 5 Outfall CSC	303.57			X	
15 OutS	CSSC	SEPA sta. 5 Outfall CSSC	303.59			X	
16	CSSC	CSSC at Highway 83	304.69	X	X		I
17	CSSC	CSSC at Power Lines	302.56	X	X		I
18	CSSC	CSSC Slip No. 2	299.55	X	X		I
19	CSSC	Romeoville	296.19		X		
20	CSSC	CECO - Will CO. Gen. Sta.	295.34		X		
21	CSSC	Lockport Lock/Dam	291.20	X		X	IIA, IIB

Notes: CR = Calumet River; LCR = Little Calumet River; CSC = Cal-Sag Channel; CSSC = Chicago Sanitary and Ship Canal. Rigging design: I = horizontal bottom line, single shroud; IA = horizontal bottom line, double shroud; II = vertical line off wall, attached shroud; IIA vertical line off wall, 2 attached shrouds; IIB = vertical line off wall, fixed shroud; III = floating shroud.

Table 3. Transect Horizontal-Vertical Location of Monitor Sensors at Monitoring Stations

Station	Horizontal location (ft) referenced to bank looking downstream			Total water depth (ft)	Probe distance (in) from	
	Distance (ft)	Left	Right		Surface	Bottom
1	15		X	14		3
2	200		X	30		3
6	50		X	3	20	
7	0	X		7	60	
9	0		X	3	30	
10	0	X		8		3
12	0		X	4	40	
13	0		X	8	48	
14	144	X	X	15		6
15	0		X	12		6
16	89	X	X	24		3
17	88	X	X	25		3
18	84	X	X	26		3
21	0t		X	26	24	
	0m				84	
	0b					24

Notes: t = near surface
m = mid-depth (variable)
b = bottom

Table 4. Dates and Conditions under which Weekly Manual Cross Section DO/Temperature Runs Were Conducted, 1996

Run	Period		Discretionary diversion (cfs) at O'Brien Lock and Dam				Operating pumps at SEPA station*		
			Planned	Actual			3	4	5
	Start	Stop	mean	Mean	Min.	Max.			
1	03/15	04/18	0	0	0	0	0	0	0
2	04/19	04/25	0	0	0	0	1	1	1
3	05/17	05/23	0	0	0	0	1	1	2
4	05/31	06/06	192	137	27	218	1	2	2 (3)
5	06/14	06/20	"	131	0	220	2	2	3
6	06/27	07/03	"	214	157	235	2	2	4
7	07/05	07/11	384	434	336	465	2 (3)	3	1
8	07/12	07/18	"	338	0	460	2 (3)	3	4
9	07/19	07/25	"	222	0	532	2	2	1
10	07/26	08/01	"	282	19	465	2	2	4
11	08/30	09/05	"	454	446	463	1	2	3
12	09/13	09/19	"	430	393	471	1	1	1
13	10/17	10/23	293	310	114	399	1	2	1
14	10/25	10/31	"	332	111	390	1	1	1
15	11/01	11/19	0	0	0	0	0	0	0

Note: * Actual and (planned) number of pumps operated.

Table 5. SEPA Station Pumping Rates and Waterway Hydraulic/Hydrologic Conditions, 1996

<i>Period</i>		<i>Operating pumps at SEPA station</i>					<i>Mean discretionary diversion (cfs)</i>			<i>Mean total diversion (cfs)</i>			<i>Mean discharge (cfs) at Romeoville</i>
<i>Start</i>	<i>Stop</i>	<i>1</i>	<i>2</i>	<i>3</i>	<i>4</i>	<i>5</i>	<i>WPS</i>	<i>CCW</i>	<i>OLD</i>	<i>WPS</i>	<i>CCW</i>	<i>OLD</i>	
03/15	04/18	0	0	0	0	0	0	0	0	3	31	51	2128
04/19	04/25	1	1	1	1	1	0	0	0	3	46	56	3543
04/26	05/17	1	1	1	1	1	0	0	0	3	77	78	3523
05/18	05/23	1	1	1	1	2	0	0	0	2	118	162	4322
05/24	05/30	1	1	1	1	2	0	0	0	2	70	107	7063
05/31	06/06	1	1	1	2	2	13	115	137	16	235	288	5776
06/07	06/10	1	1	1	2	2	0	96	126	3	219	309	4469
06/11	06/13	1	1	1	0	2	76	71	178	79	158	280	3988
06/14	06/20	1	1	2	2	3	42	59	131	45	197	253	5535
06/21	06/26	1	1	1	2	2	49	65	185	53	172	310	3773
06/27	07/04	1	1	2	2	4	86	145	245	90	307	385	3068
07/05	07/11	1	1	2	3	1	85	162	434	89	264	551	3346
07/12	07/18	1	1	2	3	4	45	126	337	48	210	442	5684
07/19	07/25	1	1	2	2	1	42	79	222	46	279	318	6766
07/26	08/01	1	1	2	2	4	56	168	282	60	283	419	4517
08/02	08/05	1	1	0	2	0	100	169	452	104	278	594	3478
08/06	08/06	1	1	0	0	0	75	123	337	79	401	703	3559
08/07	08/09	1	1	2	0	1	83	151	264	87	246	348	3586
08/10	08/11	1	1	2	1	1	81	145	463	85	459	624	3666
08/12	08/14	1	1	1	1	1	91	340	457	95	438	589	3103
08/15	08/18	1	1	2	2	2	85	305	417	89	414	565	3227
08/19	08/21	1	1	3	3	3	60	265	356	64	366	485	2975
08/22	08/23	1	1	3	3	4	36	196	265	40	336	750	4462
08/24	09/12	1	1	1	2	3	94	398	421	98	498	545	3514
09/13	09/29	1	1	1	1	1	77	286	379	82	374	505	3622
09/30	10/02	1	1	1	1	1	30	136	369	34	211	479	2824
10/03	10/06	1	1	2	2	2	0	71	443	5	154	554	2567
10/07	10/09	1	1	2	3	3	0	0	404	5	69	508	2346
10/10	10/11	1	1	2	3	4	0	0	311	5	65	402	2598
10/12	10/17	1	1	1	1	1	0	0	345	5	113	499	2700
10/18	10/23	1	1	1	2	1	0	0	315	5	93	418	2818
10/24	10/31	1	0	1	1	1	0	0	337	4	61	436	2824
11/01	11/19	0	0	0	0	0	0	0	0	4	58	74	2302

Notes: WPS = Wilmette Pumping Station, CCW = Chicago Controlling Works, OLD = O'Brien Lock and Dam. Bold face type denotes in-stream use of Datasonde I monitors during Phase II study dates. Romeoville is an USGS discharge measurement station at river mile 296.19 on the Chicago Sanitary and Ship Canal.

Table 6. Data Analysis Periods, 1996

Period	Inclusive dates	No. days	SEPA stations operating	Discretionary diversion (cfs)*		No. DO cross section profiles
				Planned	Actual	
1	03/16 - 04/18	34	0	0	0	1
2	04/19 - 05/30	42	5	0	199	2
3	05/31 - 07/03	34	5	192	162	3
4	07/04 - 09/25	84	5	384	380	6
5	09/26 - 10/31	36	5	192	336	2
6	11/01 - 11/19	19	0	0	0	1
1-6	03/16 - 11/19	249	0-5	0-384	0-380	15

Note: * Daily mean diversion

Table 7. Chronological Review of Monitor Installation and Exchange Schedule, 1996

Date	Station															
	1	2	6	7	9	10	12	13	14	15	16	17	18	21t	21m	21b
03/13			I	I	I	I	I							I	I	I
03/14								I	I	I	I	I	I			
03/15	I	I														
03/27			X	Ø	X	X	X	X	X	X	X	X				
03/28	X	X											X			
04/16														X	X	X
04/17	X	X	X	I	X	X	Ø	Ø	X	X	X		X			
04/18								I					X			
04/23							I									
05/01							X	X	X	X	X	X	X	X	X	X
05/02	X	X	X	X	X	Ø										
05/02						I										
05/21	X	X	X	X	X	X	X	X	X	X	X	X	X	X	X	X
05/30	X	X	X	X	X	X	X	X	X	X	X	X	X	X	X	X
06/12	X	X	X	X	X	X	X	X	X	Ø	X	X	X	X	X	X
06/18	X	X	X	X	X	X	X	X	X	X	X			X	X	X
06/26	X	X	X	X	X	X	X	X	X	X	X	X	X	X	X	X
07/09	X	X	X	X	X	X	X	X	X	X	X	X	X	X	X	X
07/16	X	X	X	X	X	X	X	X	X	X	X	X	X	X	X	X
07/23	X	X	X	X	X	X	X	X	X	X	X	X	X	X	X	X
07/30	O	O	X	X	X	X	X		X	X			X	X	O	O
08/08			X	X	X̄	X	X̄	X	X	X̄	X	X	X	X		
08/22			X	X		X		X	X		X	X	X	X	I	I
08/23				X	X		X			X						
08/29					X	X	X	X	X	X	X	X	X	X	X	X
08/30	I	I	X	X												
09/12							X	X	X	X	X	X	X	X	X	X
09/13	X	X	X	X	X	X										
09/26	O	O	O	O	X̄	X	X̄	X	X	X̄	X	X	X	X	O	O
10/10							X	X	X	X	X	X	X	X		
10/11	I	I	I	I	X	X										
10/21	X	X	X	X	X	X	X	X	X	X	X	X	X	X	I	I
11/06	X	X	X	X	X	X	X	X	X	X	X	X	X	X	X	X
11/20	O	O	O	O	O	O	O	O	O	O	O	O	O	O	O	O

Notes: I = installed, X = exchanged, X̄ = duplicate, O = removed but not exchanged, and Ø = destroyed or vandalized.

**Table 8. Continuous Monitoring Data Available at Monitoring Stations,
March 13-November 20, 1996**

Station	Period		Periodic data		Station	Period		Periodic data		
	Date	Time	Complete	Missing		Date	Time	Complete	Missing	
1	03/15	1100			12	03/13	1300			
	05/20	1100	X			05/15	0800	X		
	06/12	1500		X		05/21	0800		X	
	07/30	1300	X			11/20	1200	X		
	08/30	0900		X		Complete: 5754 hr = 95%				
	09/26	1400	X			13	03/14	1000		
	10/11	1100		X			03/27	1600	X	
	10/21	1500	X				04/18	1000		X
	11/06	1400		X			05/17	0800	X	
	11/20	1200	X				05/21	1300		X
Complete: 4206 hr = 70%					08/08		1300	X		
2	03/15	1000			08/22	1700		X		
	04/17	1100	X		11/20	1600	X			
	05/02	1200		X	Complete: 5064 hr = 84%					
	07/30	1300	X		14	03/14	1100			
	08/30	1000		X		05/17	0700	X		
	09/13	1000		X		05/21	1300		X	
	09/26	1400	X			09/26	1500	X		
	10/11	1000		X		10/10	1600		X	
	10/24	1300	X			11/12	0500	X		
	11/05	1100		X	11/20	1600		X		
11/20	1200	X		Complete: 5399 hr = 90%						
Complete: 3927 hr = 65%					15	03/14	1200			
6	03/13	1800				05/19	2300	X		
	05/19	1600	X			05/21	1400		X	
	06/12	1400		X		06/07	2200	X		
	09/26	1200	X			06/12	1000		X	
	10/11	0900		X		10/31	1600	X		
	11/20	1300	X			11/01	0000		X	
Complete: 5111 hr = 85%					11/20	1400	X			
7	03/13	1800			Complete: 5842 hr = 97%					
	04/17	1000		X	16	03/14	1300			
	09/26	1200	X			04/21	1100	X		
	10/11	0900		X		05/01	1600		X	
	11/20	1300	X			05/10	0000	X		
Complete: 4902 hr = 81%						05/21	1400		X	
9	03/13	1500				05/25	2000	X		
	11/20	1400	X		05/30	1400		X		
	Complete: 6048 hr = 100%					07/21	0300	X		
10	03/13	1600			07/23	1500		X		
	04/17	0700	X		09/03	1400	X			
	05/02	1000		X	09/12	1500		X		
	07/09	1600	X		09/27	1700	X			
	07/16	1900		X	10/01	0300		X		
	07/30	1000	X		10/27	1900	X			
	08/08	1400		X	11/20	1400		X		
	08/22	1600	X		Complete: 4476 hr = 74%					
	08/29	1600		X	17	03/13	1300			
	11/20	1400	X			05/15	0800	X		
Complete: 5126 hr = 85%						05/21	0800		X	
				11/20		1200	X			

Table 8. Concluded

<i>Station</i>	<i>Period</i>		<i>Periodic data</i>		<i>Station</i>	<i>Period</i>		<i>Periodic data</i>	
	<i>Date</i>	<i>Time</i>	<i>Complete</i>	<i>Missing</i>		<i>Date</i>	<i>Time</i>	<i>Complete</i>	<i>Missing</i>
17	03/14	1600			21m (mid-depth)	03/13	1200		
	05/10	0000	X			05/09	2200	X	
	05/21	1500		X		05/10	0400		X
	08/23	0300	X			05/28	1600	X	
	08/29	1300		X		05/28	2200		X
	09/03	2100	X			06/17	1700	X	
	09/12	1500		X		06/18	1600		X
	09/29	0500	X			07/30	0900	X	
	10/10	1400		X		08/22	1100		X
	10/22	1600	X			09/26	0900	X	
	11/01	1900		X		10/21	1100		X
	11/18	0900	X			11/06	1100	X	
	11/20	1500		X		11/08	0800		X
	Complete: 4826 hr = 80%						11/09	1500	X
18	03/14	1500			11/09	2000		X	
	05/01	1600	X		11/13	1700	X		
	05/02	0000		X	11/20	1000		X	
	06/12	1100	X		Complete: 4668 hr = 77%				
	06/26	1600		X	21b (bottom)	03/13	1200		
	11/20	1300	X			03/27	1100		X
Complete: 5670 hr = 94%						05/12	0300	X	
21t (near surface)	03/13	1200				05/21	0900		X
	07/09	0900	X			07/30	0900	X	
	07/16	1100		X		08/22	1100		X
	08/15	1100	X		09/26	0900	X		
	08/22	1100		X	10/21	1100		X	
	11/20	1000	X		11/20	1000	X		
Complete: 5709 hr = 94%					Complete: 4394 hr = 73%				

Table 9. Number of Usable Hourly DO Values for Recorded Continuous Monitoring Stations, March 16-November 19, 1996

<i>Station</i>	<i>Monitoring periods</i>						
	<i>1</i>	<i>2</i>	<i>3</i>	<i>4</i>	<i>5</i>	<i>6</i>	<i>1-6</i>
1	815	996	512	1275	260	322	4180
2	780	684	816	940	331	349	3900
6	814	736	514	2015	508	456	5043
7	36	1005	814	2015	508	456	4834
9	815	1007	815	2012	864	456	5969
10	776	685	815	1461	862	456	5055
12	779	752	816	2015	862	456	5680
13	295	907	816	1672	863	456	5009
14	815	905	815	2013	528	269	5345
15	815	969	709	2014	828	456	5791
16	816	374	812	1742	682	0	4426
17	814	729	815	1652	369	399	4778
18	816	1000	476	2013	862	456	5623
21t	815	1008	816	1680	863	456	5638
21m	814	1006	794	1463	263	257	4597
21b	540	786	816	1463	263	455	4323

Notes: 21t = near surface
21m = mid-depth
21b = bottom

Table 10. Summary by Period of DO and Temperature Measurements, March 16-November 19, 1996

Station	DO std.	Temperature (°C)			DO (mg/L)			Temperature (°C)			DO (mg/L)		
		Min	Mean	Max	Min	Mean	Max	Min	Mean	Max	Min	Mean	Max
Period 1 (03/16 - 04/18)													
1	5.0	4.52	6.64	10.94	7.71	10.46	12.66	17.66	20.82	23.53	6.55	7.54	8.29
2	"	3.29	5.44	8.57	9.37	12.02	13.45	15.29	19.43	23.44	5.38	7.49	9.27
6	4.0	6.67	10.35	15.71	5.76	8.29	10.38	18.29	21.38	26.06	1.56	5.80	9.32
7	"	11.87	12.84	13.90	6.24	6.59	7.01	15.08	19.75	25.13	1.11	5.21	7.19
9	3.0	6.21	9.48	14.45	5.94	8.28	10.78	14.45	20.13	25.17	2.48	4.91	6.59
10	"	6.25	9.22	12.84	5.35	7.92	10.41	14.45	19.98	25.26	2.86	5.01	6.62
12	"	6.42	8.91	12.25	4.65	7.62	9.46	14.74	20.40	26.44	0.92	4.81	8.73
13	"	6.25	7.73	12.42	7.14	8.79	10.50	14.53	20.33	26.19	2.57	5.56	7.74
14	"	5.62	8.65	12.08	5.78	8.10	10.31	14.61	20.53	26.02	1.46	5.01	7.33
15	"	5.20	8.61	11.83	5.97	7.74	10.03	14.07	21.01	25.89	1.39	4.81	7.01
16	4.0	8.83	11.52	14.78	3.89	7.34	9.46	15.63	20.49	25.93	1.17	3.97	6.37
17	"	7.01	10.27	13.64	4.49	6.55	8.52	15.21	20.69	26.27	2.75	5.20	6.86
18	"	7.77	10.54	13.35	6.15	7.48	9.08	15.04	20.07	25.64	3.61	4.75	6.51
21t	"	10.48	13.38	16.56	5.43	7.52	9.11	15.23	22.53	29.84	0.78	3.83	5.71
21m	"	10.18	13.37	16.90	5.44	7.21	8.63	15.24	22.50	29.80	1.07	3.78	5.52
21b	"	10.52	13.63	17.06	5.66	7.12	8.76	15.26	22.51	29.82	0.69	3.97	5.91
Period 2 (04/19 - 05/30)													
1	5.0	10.10	13.80	18.88	7.47	8.46	9.95	20.36	22.91	25.69	5.10	6.96	8.39
2	"	10.77	14.06	17.99	7.18	8.33	9.92	20.40	22.75	25.19	3.42	6.66	8.03
6	4.0	10.91	13.93	19.73	1.15	5.87	8.62	20.06	23.22	27.88	0.88	6.23	8.93
7	"	11.62	14.22	19.30	2.34	5.82	9.83	19.85	23.11	26.02	0.28	5.91	8.49
9	3.0	10.14	13.96	20.32	3.59	6.34	9.18	20.15	23.30	26.74	3.15	5.28	7.62
10	"	11.70	14.64	19.73	3.78	5.62	8.41	19.98	23.01	25.26	2.57	4.97	7.31
12	"	10.05	14.05	20.19	2.87	5.53	8.47	20.23	23.40	26.40	2.36	5.05	7.65
13	"	9.97	13.84	19.89	3.44	6.29	8.90	19.85	23.09	26.57	1.88	5.42	8.49
14	"	10.10	13.98	19.77	3.70	6.51	8.34	19.89	23.38	26.82	1.95	5.09	7.29
15	"	9.88	13.82	19.98	3.04	5.61	8.11	20.11	23.53	26.70	2.30	4.60	7.61
16	4.0	12.46	15.18	19.60	2.42	4.85	7.05	21.71	24.67	28.47	0.34	4.20	6.60
17	"	11.83	14.72	19.98	3.05	5.83	8.22	21.08	24.26	28.30	1.73	4.35	7.17
18	"	11.57	14.79	19.47	2.18	5.54	9.38	21.12	24.32	27.58	1.78	4.29	5.84
21t	"	13.01	16.22	21.16	2.37	5.20	7.03	22.13	26.25	30.27	1.43	3.59	5.33
21m	"	11.83	16.42	21.03	2.73	5.71	11.45	21.50	26.07	30.21	1.23	3.66	5.62
21b	"	13.31	16.56	21.12	2.77	5.58	6.93	22.26	26.19	30.33	1.12	3.91	6.39
Period 3 (05/31 - 07/03)													
Period 4 (07/04 - 09/25)													

Table 10. Concluded

Station	DO std.	Temperature (°C)			DO (mg/L)			Temperature (°C)			DO (mg/L)				
		Min	Mean	Max	Min	Mean	Max	Min	Mean	Max	Min	Mean	Max		
Period 5 (09/26 - 10/31)													Period 7 (03/16 - 11/19)		
1	5.0	13.10	15.82	20.36	7.05	8.01	8.47	4.52	15.71	25.69	5.10	8.33	12.66		
2	"	13.28	15.62	20.44	7.33	9.38	10.64	3.29	15.73	25.15	3.42	8.72	13.45		
6	4.0	12.57	16.50	20.15	5.64	7.25	8.76	6.67	17.99	27.88	0.88	6.67	10.38		
7	"	13.27	16.74	20.44	5.26	6.86	8.04	11.62	19.02	26.02	0.28	5.98	9.83		
9	3.0	12.22	16.83	20.15	4.68	6.48	8.13	6.21	17.54	26.74	2.48	6.10	10.78		
10	"	11.99	16.82	19.98	4.72	6.43	8.12	6.25	17.13	25.26	2.57	5.91	10.41		
12	"	11.88	16.50	20.23	4.31	6.37	8.40	6.42	17.51	26.44	0.92	5.77	9.46		
13	"	11.60	16.46	20.02	4.51	6.69	8.45	6.25	17.62	26.57	1.88	6.11	10.50		
14	"	11.71	15.56	19.98	5.06	6.46	7.96	5.62	17.27	26.82	1.46	5.96	10.31		
15	"	11.66	16.27	19.89	3.93	6.02	8.27	5.20	17.28	26.70	1.39	5.63	10.03		
16	4.0	16.04	19.84	23.10	0.35	5.40	7.14	8.83	19.27	28.47	0.34	4.98	9.46		
17	"	14.29	18.27	21.75	1.30	5.72	6.82	7.01	18.51	28.30	1.30	5.36	8.52		
18	"	14.84	18.45	21.33	1.78	5.24	6.43	7.77	18.46	27.58	1.78	5.29	9.38		
21t	"	17.28	19.95	23.99	1.30	4.67	6.16	10.48	20.19	30.27	0.78	4.81	9.11		
21m	"	17.25	19.21	23.19	3.49	5.46	6.93	10.18	19.88	30.21	1.07	5.00	11.45		
21b	"	17.26	19.23	24.29	3.71	5.30	6.53	10.52	20.01	30.33	0.69	4.92	8.76		
Period 6 (11/01 - 11/19)															
1	5.0	7.60	10.10	13.10	8.79	9.45	10.30								
2	"	6.84	9.76	13.28	8.77	9.86	11.17								
6	4.0	10.98	13.27	15.84	6.25	7.35	8.21								
7	"	11.87	13.22	15.42	4.92	6.95	8.12								
9	3.0	9.02	11.13	14.94	4.79	6.71	8.08								
10	"	9.06	11.01	14.77	5.08	6.58	8.16								
12	"	7.62	9.72	13.32	5.39	6.84	8.15								
13	"	7.14	9.59	13.35	4.32	6.39	7.87								
14	"	6.69	9.13	12.28	4.88	6.10	7.29								
15	"	6.27	8.98	12.42	5.60	6.96	8.48								
16	4.0	11.25	15.13	17.30	-	-	-								
17	"	9.22	12.77	15.43	4.19	6.20	7.39								
18	"	10.79	13.20	15.41	3.95	5.95	7.13								
21t	"	12.62	15.06	17.37	4.57	5.62	6.74								
21m	"	12.46	15.14	17.36	5.11	6.15	7.54								
21b	"	12.88	15.14	17.34	4.60	5.87	7.16								

Notes: DO std. = dissolved oxygen standard, in mg/L, at designated station

21t = near surface

21m = mid-depth

21b = bottom

Table 11. Summary by Station of DO and Temperature Measurements, March 16 - November 19, 1996

Period	Date	Temperature (°C)			DO (mg/L)			Temperature (°C)			DO (mg/L)		
		Min	Mean	Max	Min	Mean	Max	Min	Mean	Max	Min	Mean	Max
Station 1 (RM 328.10)													
1	03/16-04/18	4.52	6.64	10.94	7.71	10.46	12.66	6.25	9.22	12.84	5.35	7.92	10.41
2	04/19-05/30	10.10	13.80	18.88	7.47	8.46	9.95	11.70	14.54	19.73	3.78	5.62	8.41
3	05/31-07/03	17.66	20.82	23.53	6.55	7.54	8.29	14.75	19.98	25.26	2.86	5.01	6.62
4	07/04-09/25	20.36	22.91	25.69	5.10	6.96	8.39	19.98	23.01	25.26	2.57	4.97	7.31
5	09/26-10/31	13.10	15.82	20.36	7.05	8.01	8.47	11.99	16.82	19.98	4.72	6.43	8.12
6	11/01-11-19	7.60	10.10	13.10	8.79	9.45	10.30	9.06	11.01	14.77	5.08	6.58	8.16
1-6	03/16-11/19	4.52	15.71	25.69	5.10	8.33	12.66	6.25	17.13	25.26	2.57	5.91	10.41
Station 2 (RM 327.69)													
1	03/16-04/18	3.29	5.44	8.57	9.37	12.02	13.45	6.42	8.91	12.25	4.65	7.62	9.46
2	04/19-05/30	10.77	14.06	17.99	7.18	8.33	9.92	10.05	14.05	20.19	2.87	5.53	8.47
3	05/31-07/03	15.29	19.43	23.44	5.38	7.49	9.27	14.74	20.40	26.44	0.92	4.81	8.73
4	07/04-09/25	20.40	22.75	25.19	3.42	6.66	8.03	20.23	23.40	26.40	2.36	5.05	7.65
5	09/26-10/31	13.28	15.62	20.44	7.33	9.38	10.64	11.88	16.50	20.23	4.31	6.37	8.40
6	11/01-11-19	6.84	9.76	13.28	8.77	9.86	11.17	7.62	9.72	13.32	5.39	6.84	8.15
1-6	03/16-11/19	3.29	15.73	25.15	3.42	8.72	13.45	6.42	17.51	26.44	0.92	5.77	9.46
Station 6 (RM 321.32)													
1	03/16-04/18	6.67	10.35	15.71	5.76	8.29	10.38	6.25	7.73	12.42	7.14	8.79	10.50
2	04/19-05/30	10.91	13.93	19.73	1.15	5.87	8.62	9.97	13.84	19.89	3.44	6.29	8.90
3	05/31-07/03	18.29	21.38	26.06	1.56	5.80	9.32	14.53	20.33	26.19	2.57	5.56	7.74
4	07/04-09/25	20.06	23.22	27.88	0.88	6.23	8.63	19.85	23.09	26.57	1.88	5.42	8.49
5	09/26-10/31	12.57	16.50	20.15	5.64	7.25	8.76	11.60	16.46	20.02	4.51	6.69	8.45
6	11/01-11-19	10.98	13.27	15.81	6.25	7.35	8.21	7.14	9.59	13.35	4.32	6.39	7.87
1-6	03/16-11/19	6.67	17.99	27.88	0.88	6.67	10.38	6.25	17.62	26.57	1.88	6.11	10.50
Station 7 (RM 320.71)													
1	03/16-04/18	11.87	12.84	13.90	6.24	6.59	7.01	5.62	8.65	12.08	5.78	8.10	10.31
2	04/19-05/30	11.62	14.22	19.30	2.34	5.82	9.83	10.10	13.98	19.77	3.70	6.51	8.34
3	05/31-07/03	15.08	19.75	25.13	1.11	5.21	7.19	14.61	20.53	26.02	1.46	5.01	7.33
4	07/04-09/25	19.85	23.11	26.02	0.28	5.91	8.49	19.89	23.38	26.82	1.95	5.09	7.29
5	09/26-10/31	13.27	16.74	20.44	5.26	6.86	8.04	11.71	15.56	19.98	5.06	6.46	7.96
6	11/01-11-19	11.87	13.22	15.42	4.92	6.95	8.12	6.69	9.13	12.28	4.88	6.10	7.29
1-6	03/16-11/19	11.62	19.02	26.02	0.28	5.98	9.83	5.62	17.27	26.82	1.46	5.96	10.31
Station 9 (RM 318.08)													
1	03/16-04/18	6.21	9.48	14.45	5.94	8.28	10.78	5.20	8.61	11.83	5.97	7.74	10.03
2	04/19-05/30	10.14	13.96	20.32	3.59	6.34	9.18	9.88	13.82	19.98	3.04	5.61	8.11
3	05/31-07/03	14.45	20.13	25.17	2.48	4.91	6.59	14.07	21.01	25.89	1.39	4.81	7.01
4	07/04-09/25	20.15	23.30	26.74	3.15	5.28	7.62	20.11	23.53	26.70	2.30	4.60	7.61
5	09/26-10/31	12.22	16.83	20.15	4.68	6.48	8.13	11.66	16.27	19.89	3.93	6.02	8.27
6	11/01-11-19	9.02	11.13	14.94	4.79	6.71	8.08	6.27	8.98	12.42	5.60	6.96	8.48
1-6	03/16-11/19	6.21	17.54	26.74	2.48	6.10	10.78	5.20	17.28	26.70	1.39	5.63	10.03
Station 10 (RM 317.62)													
Station 12 (RM 311.55)													
Station 13 (RM310.70)													
Station 14 (RM 307.15)													
Station 15 (RM303.63)													

Table 11. Concluded

Period	Date	Temperature (°C)			DO (mg/L)			Temperature (°C)			DO (mg/L)		
		Min	Mean	Max	Min	Mean	Max	Min	Mean	Max	Min	Mean	Max
		Station 16 (RM 304.69)						Station 21t (RM 291.20)					
1	03/16-04/18	8.83	11.52	14.78	3.89	7.34	9.46	10.48	13.38	16.56	5.43	7.52	9.11
2	04/19-05/30	12.46	15.18	19.60	2.42	4.85	7.05	13.01	16.22	21.16	2.37	5.20	7.03
3	05/31-07/03	15.63	20.49	25.93	1.17	3.97	6.37	15.23	22.53	29.84	0.78	3.83	5.71
4	07/04-09/25	21.71	24.67	28.47	0.34	4.20	6.60	22.13	26.25	30.27	1.43	3.59	5.33
5	09/26-10/31	16.04	19.84	23.10	0.35	5.40	7.14	17.28	19.95	23.99	1.30	4.67	6.16
6	11/01-11-19	11.25	15.13	17.30	-	-	-	12.62	15.06	17.37	4.57	5.62	6.74
1-6	03/16-11/19	8.83	19.27	28.47	0.34	4.98	9.46	10.48	20.19	30.27	0.78	4.81	9.11
		Station 17 (RM 302.56)						Station 21m (RM 291.20)					
1	03/16-04/18	7.01	10.27	13.64	4.49	6.55	8.52	10.18	13.37	16.90	5.44	7.21	8.63
2	04/19-05/30	11.83	14.72	19.98	3.05	5.83	8.22	11.83	16.42	21.03	2.73	5.71	11.45
3	05/31-07/03	15.21	20.69	26.27	2.75	5.20	6.86	15.24	22.50	29.80	1.07	3.78	5.52
4	07/04-09/25	21.08	24.26	28.30	1.73	4.35	7.17	21.50	26.07	30.21	1.23	3.66	5.62
5	09/26-10/31	14.29	18.27	21.75	1.30	5.72	6.82	17.25	19.21	23.19	3.49	5.46	6.93
6	11/01-11-19	9.22	12.77	15.43	4.19	6.20	7.39	12.46	15.14	17.36	5.11	6.15	7.54
1-6	03/16-11/19	7.01	18.51	28.30	1.30	5.36	8.52	10.18	19.88	30.21	1.07	5.00	11.45
		Station 18 (RM 299.55)						Station 21b (RM 291.20)					
1	03/16-04/18	7.77	10.54	13.50	6.15	7.48	9.08	10.52	13.63	17.06	5.66	7.12	8.76
2	04/19-05/30	11.57	14.79	19.47	2.18	5.54	9.38	13.31	16.56	21.12	2.77	5.58	6.93
3	05/31-07/03	15.04	20.07	25.64	3.61	4.75	6.51	15.26	22.51	29.82	0.69	3.97	5.91
4	07/04-09/25	21.12	24.32	27.58	1.78	4.29	5.84	22.26	26.19	30.33	1.12	3.91	6.39
5	09/26-10/31	14.84	18.45	21.33	1.78	5.24	6.43	17.26	19.23	24.29	3.71	5.30	6.53
6	11/01-11-19	10.79	13.20	15.41	3.95	5.95	7.13	12.88	15.14	17.34	4.60	5.87	7.16
1-6	03/16-11/19	7.77	18.46	27.58	1.78	5.29	9.38	10.52	20.01	30.33	0.69	4.92	8.76

Notes: 21t = near surface
21m = mid-depth
21b = bottom

Table 12. Summary of Cross-Sectional DO and Temperature Data by Station, Including Monitor Readings at Continuous Monitoring Stations, 1996

Date	Monitor reading		Begin time	N	Cross-sectional data					
	DO (mg/L)	Temp (°C)			DO (mg/L)			Temperature (°C)		
					Min	Mean	Max	Min	Mean	Max
Station 1, RM 328.10, DO std = 5.0 mg/L										
03/28	11.53	5.30	1525	12	11.30	11.40	11.63	5.1	5.3	5.4
04/23	8.71	11.01	1505	19	9.05	10.84	12.27	11.3	11.5	11.8
05/22	7.72	18.76	1820	15	8.74	9.58	10.20	18.2	19.2	19.9
06/05	-	-	1528	32	7.44	8.04	9.09	17.8	18.6	19.8
06/19	7.42	20.06	0946	46	7.41	7.48	7.54	19.5	19.9	20.1
07/02	7.80	22.22	1004	46	7.34	7.48	7.61	22.1	22.4	22.8
07/10	7.45	21.84	1118	43	7.13	7.32	7.73	21.6	21.9	22.3
07/17	7.23	22.90	0932	35	7.07	7.24	7.46	21.6	22.8	23.0
07/24	5.65	23.15	1009	30	6.13	6.31	6.61	23.4	23.5	23.9
07/31	-	-	1005	32	6.77	7.05	7.31	22.4	22.6	22.8
09/04	7.08	24.23	0945	29	6.92	7.23	7.63	24.0	24.2	24.7
09/18	6.96	22.05	0829	35	5.77	6.70	7.72	21.8	21.9	22.0
10/22	-	15.33	0922	21	8.76	9.26	9.55	14.9	14.9	14.9
10/30	-	14.59	0931	15	8.87	8.96	9.07	14.4	14.5	14.5
11/13	9.43	9.23	1005	14	8.18	8.91	9.46	9.0	9.2	9.3
Station 2, RM 327.69, DO std = 5.0 mg/L										
03/28	12.76	4.14	1451	14	12.49	12.69	12.78	4.2	4.4	4.5
04/23	-	-	1435	15	11.90	13.04	13.96	10.9	11.1	11.4
05/22	7.44	17.00	1734	18	8.96	9.54	9.93	17.5	18.8	19.3
06/05	7.72	17.34	1432	30	6.97	8.39	9.59	17.3	18.4	19.4
06/19	6.85	19.47	1038	53	5.98	7.17	7.50	19.3	19.9	20.5
07/02	7.20	22.79	1058	38	7.00	7.15	8.44	22.7	22.9	23.6
07/10	6.58	21.75	1006	53	7.02	7.72	8.07	21.6	21.9	22.5
07/17	7.26	22.98	1024	29	6.84	7.12	7.30	22.7	22.9	23.8
07/24	5.35	22.94	1045	30	5.35	6.13	6.50	23.1	23.5	24.2
07/31	-	-	1102	30	7.09	7.70	8.35	22.5	22.8	23.2
09/04	-	23.87	1040	25	6.99	7.59	8.03	23.8	24.2	24.7
09/18	7.46	21.94	0928	37	7.34	7.69	8.01	21.6	21.9	22.1
10/22	8.64	15.27	1016	26	8.21	9.24	9.91	14.8	14.9	15.0
10/30	-	14.49	0954	8	9.28	9.37	9.42	14.2	14.2	14.2
11/13	9.99	8.66	1033	7	8.99	9.27	9.84	8.5	8.6	8.6
Station 3, RM 326.02, DO std = 5.0 mg/L										
03/28			1544	3	13.77	13.89	13.97	4.0	4.0	4.0
04/23			1422	8	9.08	10.70	13.33	10.9	11.3	11.6
05/22			1722	5	9.22	10.64	11.77	17.8	18.7	19.4
06/05			1625	5	7.80	8.20	8.58	18.0	18.2	18.4
06/19			1119	7	6.49	6.69	6.85	20.3	20.5	20.7
07/02			1148	8	6.04	6.27	6.50	23.1	23.4	23.7
07/10			0952	7	6.80	7.00	7.45	22.0	22.2	22.6
07/17			1051	4	6.43	6.60	6.70	22.8	22.9	23.0
07/24			1123	4	4.93	5.20	5.53	23.0	23.2	23.5
07/31			1140	6	7.02	7.06	7.17	22.9	23.0	23.1
09/04			1122	5	6.91	7.14	7.27	23.9	24.0	24.3
09/18			1000	8	7.41	7.59	7.72	21.5	21.7	21.8
10/22			1057	5	8.55	8.98	9.25	14.7	14.7	14.7
10/30			1008	7	9.11	9.21	9.35	13.7	13.8	13.8
11/13			1036	7	9.38	9.60	9.99	7.2	7.3	7.4

Table 12. Continued

Date	Monitor reading		Begin time	N	Cross-sectional data					
	DO (mg/L)	Temp (°C)			DO (mg/L)			Temperature (°C)		
					Min	Mean	Max	Min	Mean	Max
Station 4, RM 325.31, DO std = 4.0 mg/L										
03/28			1322	11	12.50	12.61	12.76	4.0	4.8	5.0
04/23			1332	21	3.71	4.32	5.86	12.0	12.5	12.8
05/22			1618	15	3.45	4.80	5.84	18.4	19.5	20.6
06/05			1250	17	4.83	6.12	7.59	16.9	18.2	19.8
06/19			1214	33	0.44	0.52	1.04	20.9	21.1	21.8
07/02			1251	29	5.65	5.89	6.26	23.9	24.1	24.9
07/10			1243	28	6.63	6.88	7.52	22.3	22.7	23.5
07/17			1127	26	5.79	6.02	6.15	23.4	23.5	23.6
07/24			1323	18	4.99	5.28	5.49	23.4	23.6	23.7
07/31			1219	27	3.88	4.53	5.04	22.4	22.9	23.3
09/04			1238	20	6.53	6.88	7.50	23.9	24.2	25.6
09/18			1055	25	7.13	7.54	7.75	21.0	21.3	21.6
10/22			1137	14	7.88	8.22	8.53	15.0	15.0	15.0
10/30			1045	7	8.53	8.65	8.84	13.3	13.4	13.4
11/13			1140	6	8.34	8.44	8.59	6.6	6.6	6.6
Station 5, RM 322.66, DO std = 4.0 mg/L										
03/28			1300	11	15.00	15.33	15.70	4.3	4.5	4.7
04/23			1306	18	7.77	8.27	9.13	12.8	13.2	14.1
05/22			1533	22	5.90	6.80	7.51	19.3	20.6	21.8
06/05			1154	23	5.73	6.30	7.14	17.8	18.4	19.7
06/19			1311	31	5.41	6.03	7.42	21.7	22.0	23.0
07/02			1324	28	5.50	6.07	6.63	25.2	25.5	25.9
07/10			1327	29	6.83	7.58	8.54	22.7	23.2	24.3
07/17			1212	28	6.68	7.03	7.61	23.8	23.9	24.0
07/24			1352	23	4.27	4.61	5.23	23.6	23.8	24.3
07/31			1259	25	4.35	4.78	5.14	23.0	23.4	23.9
09/04			1308	18	7.14	7.41	7.90	24.1	24.4	25.1
09/18			1132	26	7.43	7.70	7.99	20.6	21.2	22.0
10/22			1210	19	7.82	8.23	8.49	14.6	14.6	14.7
10/30			1115	8	8.84	8.93	9.01	13.1	13.1	13.1
11/13			1207	6	9.19	9.31	9.66	5.3	5.4	5.4
Station 6, RM 321.32, DO std = 4.0 mg/L										
03/28	7.80	10.67	1222	17	7.02	7.81	8.24	9.9	10.1	10.5
04/23	7.00	13.23	1223	24	5.69	6.58	7.71	13.1	13.4	13.9
05/22	-	-	1439	26	5.95	6.74	8.20	17.9	19.4	20.3
06/05	-	-	0904	48	4.87	5.76	7.43	16.4	16.7	17.1
06/19	5.17	19.45	1353	49	4.51	5.32	6.52	19.3	19.4	19.7
07/02	5.83	23.82	1343	27	4.23	6.32	6.97	22.6	23.4	24.3
07/10	8.23	23.62	1408	40	6.08	6.85	8.22	21.8	22.7	24.1
07/17	6.84	23.18	1315	17	5.61	6.11	6.64	22.6	22.9	23.2
07/24	5.35	23.06	1428	33	3.99	4.84	6.99	22.4	22.6	23.0
07/31	6.97	22.56	1342	23	5.32	5.77	6.57	22.0	22.3	22.4
09/04	7.53	25.59	1347	20	4.29	6.41	7.44	22.2	24.0	25.6
09/18	6.26	22.18	1203	25	5.56	6.74	7.22	21.2	21.6	22.6
10/22	6.91	17.10	1300	22	7.04	8.23	8.65	16.3	16.8	17.1
10/30	7.49	15.18	1130	20	7.11	7.47	7.77	15.1	15.2	15.3
11/13	7.08	12.65	1219	18	6.52	6.92	8.85	11.7	12.2	12.4

Table 12. Continued

<i>Date</i>	<i>Monitor reading</i>		<i>Begin time</i>	<i>N</i>	<i>Cross-sectional data</i>					
	<i>DO (mg/L)</i>	<i>Temp (°C)</i>			<i>DO (mg/L)</i>			<i>Temperature (°C)</i>		
					<i>Min</i>	<i>Mean</i>	<i>Max</i>	<i>Min</i>	<i>Mean</i>	<i>Max</i>
Station 7, RM 320.71, DO std = 4.0 mg/L										
03/28	-	-	1052	19	7.26	7.49	7.86	9.6	9.9	12.2
04/23	6.48	12.80	1152	25	5.23	5.51	6.08	13.1	13.4	14.2
05/22	5.58	17.85	1327	37	2.99	5.09	6.45	17.5	18.6	20.0
06/05	5.69	17.07	1044	34	5.00	5.51	6.02	16.5	17.0	18.5
06/19	4.45	19.81	1454	23	4.38	4.70	4.87	19.4	19.6	19.8
07/02	4.97	23.57	1253	22	4.99	5.41	5.89	22.9	23.4	24.2
07/10	6.19	23.28	1505	27	6.22	6.85	7.78	22.4	22.9	23.6
07/17	4.85	22.98								
07/24	3.74	22.96	1514	25	3.53	4.35	5.34	22.7	23.1	23.9
07/31	4.77	22.49	1417	22	4.96	5.35	5.87	22.0	22.4	23.0
09/04	7.76	24.62	1428	17	4.96	5.60	6.80	24.3	24.4	24.7
09/18	6.91	21.95	1259	24	6.08	6.68	7.11	21.4	21.8	22.3
10/22	6.32	16.85	1243	10	7.66	7.87	8.04	16.7	16.8	16.8
10/30	6.70	15.65	1150	7	6.81	6.91	7.03	15.3	15.3	15.3
11/13	6.30	13.24	1240	10	6.44	6.59	6.80	12.7	12.9	13.1
Station 8, RM 318.51, DO std = 3.0 mg/L										
03/28			1032	9	8.53	8.54	8.59	8.0	8.1	8.1
04/23			1114	14	5.72	6.24	6.67	11.9	12.4	12.8
05/22			1250	24	4.43	4.79	5.51	18.3	18.8	20.0
06/05			0901	23	4.86	5.10	5.49	16.3	16.4	16.6
06/19			1540	14	3.77	3.89	4.10	20.5	20.6	21.0
07/02			1151	23	4.10	4.72	5.18	23.5	23.9	24.3
07/10			1519	32	6.39	6.76	7.39	22.8	22.9	23.2
07/31			1456	12	4.42	4.64	4.95	21.6	21.6	21.7
09/04			1446	25	5.41	5.60	5.92	24.1	24.1	24.2
09/18			1432	25	5.72	6.00	6.26	21.0	21.3	21.6
10/22			1218	11	7.24	7.47	7.79	16.1	16.1	16.2
10/30			1209	7	6.52	6.55	6.57	14.2	14.2	14.3
11/13			1305	6	6.76	6.92	7.15	10.5	10.8	10.9
Station 9, RM 318.08, DO std = 3.0 mg/L										
03/28	8.93	7.33	1014	11	8.96	9.00	9.04	7.6	7.7	7.8
04/23	5.89	11.74	1045	15	5.88	6.14	6.28	11.7	12.0	12.4
05/22	4.49	19.98	1157	30	4.09	5.55	6.70	18.2	18.7	20.1
06/05	5.43	17.87	0945	25	4.48	5.05	5.28	16.3	16.5	17.0
06/19	4.26	21.01	1413	20	3.55	3.83	4.01	20.5	20.6	20.6
07/02	3.45	24.21	1100	24	3.98	4.27	4.76	23.5	23.8	24.4
07/10	6.12	22.34	0848	26	5.62	5.82	6.06	22.1	22.2	22.3
07/17	6.06	23.85	0833	34	4.68	4.94	5.24	23.5	23.5	23.7
07/24	4.01	22.02	0841	29	3.07	3.35	3.65	21.5	21.6	21.9
07/31	4.50	21.38	0904	32	4.03	4.22	4.40	20.9	21.0	21.2
09/04	6.11	24.33	1418	21	5.47	5.80	5.97	24.1	24.1	24.2
09/18	6.03	21.67	1356	22	5.48	5.70	5.99	20.9	21.1	21.6
10/22	6.56	16.22	1157	20	7.27	7.45	7.61	16.0	16.1	16.1
10/30	7.17	14.42	1223	12	6.13	6.22	6.42	14.2	14.2	14.3
11/13	6.91	10.62	1313	9	6.78	7.05	7.24	10.4	10.7	10.8

Table 12. Continued

<i>Date</i>	<i>Monitor reading</i>		<i>Begin time</i>	<i>N</i>	<i>Cross-sectional data</i>					
	<i>DO (mg/L)</i>	<i>Temp (°C)</i>			<i>DO (mg/L)</i>			<i>Temperature (°C)</i>		
					<i>Min</i>	<i>Mean</i>	<i>Max</i>	<i>Min</i>	<i>Mean</i>	<i>Max</i>
Station 10, RM 317.62, DO std = 3.0 mg/L										
03/28	8.55	7.35	0956	11	8.49	8.59	8.66	7.5	7.5	7.6
04/23	-	-	0951	42	6.24	7.16	8.38	11.7	12.1	12.6
05/22	4.34	17.85	1057	39	4.77	6.95	9.54	17.9	18.2	19.5
06/05	5.11	16.75	1052	26	4.90	5.44	6.74	16.4	16.8	17.8
06/19	4.16	20.91	1454	20	3.54	4.21	4.82	20.7	20.7	20.9
07/02	4.58	23.95	0956	24	4.87	5.37	5.75	23.6	23.8	24.3
07/10	-	-	0943	31	5.87	6.17	6.62	22.2	22.3	22.6
07/17	6.15	23.74	1015	33	5.59	5.82	6.07	23.6	23.7	23.8
07/24	3.50	21.88	0946	33	3.21	3.90	5.07	21.6	21.7	21.9
07/24	3.85	22.77	1550	24	3.56	4.25	5.12	22.5	22.6	22.8
07/31	-	-	1022	25	3.93	4.67	5.93	21.0	21.2	21.5
09/04	5.85	24.26	1330	25	5.50	5.79	6.13	24.1	24.2	24.6
09/18	5.62	21.00	1312	25	5.62	6.10	6.52	20.7	21.1	21.8
10/22	6.23	16.18	1132	10	7.78	7.96	8.06	16.0	16.1	16.1
10/30	6.23	14.35	1250	18	6.28	6.72	7.20	14.1	14.3	14.4
11/13	6.99	10.05	1323	11	6.80	7.12	7.32	9.9	10.0	10.0
Station 11, RM 316.00, DO std = 3.0 mg/L										
03/28			0930	14	7.98	8.07	8.21	7.2	7.2	7.2
04/23			0858	41	6.24	8.12	9.26	11.7	12.1	12.3
05/22			0953	39	4.93	7.70	8.91	17.4	17.7	18.2
06/05			1148	24	5.12	5.25	5.57	16.5	16.9	17.9
06/19			1329	23	3.77	4.20	4.63	21.1	21.2	21.3
07/02			0905	26	4.35	4.89	5.19	24.1	24.2	24.3
07/10			1036	29	5.91	6.30	7.00	22.5	22.8	23.6
07/17			1048	33	4.99	5.33	5.54	23.6	23.7	23.7
07/24			1025	33	3.62	3.85	4.27	21.7	21.9	22.4
07/31			1112	26	4.00	4.37	4.75	20.9	21.1	21.7
09/04			1545	27	5.68	5.87	6.16	24.2	24.4	24.5
09/18			1238	27	5.25	5.60	5.85	20.7	21.0	21.4
10/22			1112	9	7.15	7.21	7.38	15.6	15.7	15.7
10/30			1314	20	6.07	6.29	6.48	14.3	14.4	14.4
11/13			1342	5	6.93	6.99	7.12	9.3	9.4	9.4
Station 12, RM 311.55, DO std = 3.0 mg/L										
03/28	8.23	7.05	1646	8	8.78	8.88	9.10	6.8	6.9	7.1
04/23	6.47	12.21	0929	21	6.18	6.29	6.43	11.9	12.0	12.0
05/22	4.22	18.27	1003	23	3.56	3.62	3.70	17.8	17.9	18.1
06/05	4.80	17.55	1300	24	4.85	5.00	5.18	17.1	17.4	18.1
06/19	2.40	21.61	1241	20	2.04	2.47	2.67	21.1	21.2	21.5
07/02	3.88	24.79	0844	17	3.78	3.94	4.17	24.5	24.6	24.9
07/10	5.60	23.57	1133	37	5.36	6.13	7.06	22.8	23.3	24.0
07/17	4.48	24.06	1207	29	4.34	4.78	5.09	23.6	23.8	23.8
07/24	3.47	22.77	1102	23	3.41	3.46	3.51	22.2	22.3	22.4
07/31	3.57	22.13	1201	23	3.57	3.76	3.96	21.4	21.5	21.8
09/04	5.74	24.29	1120	23	5.29	5.36	5.55	24.0	24.2	24.5
09/18	6.79	21.31	1152	23	5.68	5.90	6.66	20.4	20.6	21.3
10/22	6.47	15.53	1038	17	7.06	7.38	7.56	15.4	15.4	15.4
10/30	8.32	14.22	1358	14	7.21	7.31	7.53	14.0	14.1	14.2
11/13	6.90	8.29	1303	13	6.41	6.60	6.78	8.1	8.2	8.2

Table 12. Continued

Date	Monitor reading		Begin time	N	Cross-sectional data					
	DO (mg/L)	Temp (°C)			DO (mg/L)			Temperature (°C)		
					Min	Mean	Max	Min	Mean	Max
Station 13, RM 310.70, DO std = 3.0 mg/L										
03/28	-	-	1622	10	8.74	8.86	9.01	6.9	6.9	7.1
04/23	6.54	12.25	1014	21	6.27	6.62	7.01	12.0	12.1	12.2
05/22	4.60	18.25	1049	23	4.03	4.19	4.36	17.9	18.2	19.1
06/05	6.44	17.87	1437	24	4.89	5.46	5.92	17.4	17.6	18.3
06/19	2.68	21.46	1135	30	1.76	2.66	3.43	21.1	21.2	21.8
07/02	4.91	24.90	0936	24	4.56	4.97	5.41	24.6	24.8	25.7
07/10	6.73	23.45	1241	35	6.60	7.25	8.16	23.0	23.6	24.6
07/17	6.30	24.04	1252	32	5.50	5.83	6.01	23.8	23.8	23.8
07/24	4.42	22.66	1207	43	3.40	3.96	4.67	22.3	22.3	22.5
07/31	4.48	21.80	1305	26	3.34	3.91	4.68	21.5	21.6	21.7
09/04	6.20	24.62	1216	26	5.89	5.98	6.16	24.3	24.5	24.9
09/18	6.38	20.43	1057	26	5.50	5.80	6.16	20.0	20.2	20.6
10/22	7.37	15.50	1010	13	6.84	7.69	7.87	15.3	15.4	15.4
10/30	8.33	14.07	1348	17	7.10	7.51	7.93	13.9	14.0	14.0
11/13	6.46	7.98	1246	14	6.35	6.48	6.65	8.1	8.1	8.2
Station 14, RM 307.15, DO std = 3.0 mg/L										
03/28	9.38	7.18	1554	11	9.38	9.47	9.69	7.1	7.2	7.2
04/23	6.49	12.54	1053	20	6.38	6.43	6.51	12.2	12.3	12.9
05/22	3.98	19.31	1128	20	3.83	3.97	4.17	19.0	19.2	19.7
06/05	5.57	17.85	1521	23	5.08	5.27	5.62	17.4	17.7	18.4
06/19	1.61	21.19	1035	30	1.23	2.03	4.27	20.9	21.3	22.6
07/02	4.72	25.13	1026	20	4.12	4.56	4.99	25.0	25.3	26.2
07/10	5.97	23.36	1334	29	6.22	7.04	8.19	23.2	23.8	24.8
07/17	5.62	24.12	1410	18	5.36	5.47	5.72	23.6	23.6	23.6
07/24	3.61	22.50	1257	29	3.76	3.97	4.08	22.1	22.3	22.6
07/31	3.04	21.90	1352	24	2.96	3.15	3.53	21.5	21.6	21.9
09/04	5.70	24.15	1041	31	5.21	5.37	5.46	24.1	24.1	24.2
09/18	6.21	20.02	1008	26	5.01	5.20	5.49	19.8	20.0	21.0
10/22	6.76	15.42	0942	13	7.42	7.55	7.73	15.2	15.3	15.3
10/30	7.48	13.95	1313	14	7.08	7.36	7.47	13.7	13.8	13.9
11/13		7.81	1227	7	6.08	6.24	6.44	7.6	7.6	7.6
Station 15, RM 303.63, DO std = 3.0 mg/L										
03/28	8.31	6.93	1517	11	8.35	8.42	8.67	6.9	7.0	7.1
04/23	5.94	12.78	1128	20	5.78	5.86	5.95	12.5	12.7	13.4
05/22	4.03	18.74	1213	32	4.01	4.25	4.40	18.7	18.9	19.4
06/05	5.73	17.83	1521	30	4.74	4.84	4.95	17.7	17.8	18.3
06/19	2.03	21.06	0933	25	1.81	1.97	2.55	21.0	21.1	21.5
07/02	4.23	25.28	1110	25	4.19	5.09	5.73	25.3	25.9	26.6
07/10	6.12	23.80	1418	39	6.31	7.65	9.22	23.5	24.0	24.7
07/24	3.31	22.24	1343	34	3.59	3.78	3.98	22.0	22.1	23.2
07/31	3.47	21.90	1438	33	3.77	3.85	4.28	21.7	21.8	21.8
09/04	5.19	24.34	0923	29	5.19	5.59	5.99	24.2	24.3	24.8
09/05	5.31	24.58	1256	29	5.20	5.30	5.46	24.4	24.6	24.9
09/18	5.31	20.51	0918	33	4.75	5.12	5.38	19.9	21.0	21.8
09/19	5.61	21.38	1214	26	5.29	5.62	5.78	20.8	21.5	22.1
10/22	5.98	15.07	0913	21	5.97	6.71	6.97	14.9	15.0	15.0
10.23	6.47	15.22	0923	7	7.03	7.17	7.24	14.8	14.9	14.9
10/30		13.82	1232	21	6.24	7.10	7.36	13.7	14.5	15.0
11/13	6.42	7.66	1203	15	5.77	6.02	6.59	7.4	8.5	11.3

Table 12. Continued

Date	Monitor reading		Begin time	N	Cross-sectional data					
	DO (mg/L)	Temp (°C)			DO (mg/L)			Temperature (°C)		
					Min	Mean	Max	Min	Mean	Max
Station 16, RM 304.69, DO std = 4.0 mg/L										
03/28	8.06	10.01	1450	12	7.66	7.70	7.75	10.0	10.0	10.1
04/23	-	13.52	1227	14	6.64	6.68	6.75	13.3	13.4	13.6
05/22	3.54	18.90	1313	18	4.68	4.80	4.97	18.7	18.8	19.1
06/05	2.77	17.87	1408	12	4.72	4.83	4.89	17.9	18.0	18.1
06/19	3.43	20.59	1329	5	3.35	3.53	3.62	20.6	20.7	20.8
07/02	4.82	25.11	1205	21	5.22	5.59	6.21	25.5	25.6	25.9
07/10	4.13	23.59	1300	27	4.15	4.35	4.73	23.5	23.6	24.0
07/24	4.25	23.91	1513	23	3.66	3.82	3.98	23.7	23.8	24.0
07/31	3.06	23.70	1351	27	3.89	4.04	4.19	23.6	23.7	23.8
09/05	-	26.67	1351	27	4.36	4.55	4.85	26.6	26.7	27.0
09/19	5.69	22.22	1119	27	5.10	5.17	5.23	21.9	21.9	22.1
10/22	5.63	20.13	0828	12	6.06	6.20	6.36	19.7	19.9	19.9
10/23	5.57	20.18	0929	7	5.09	5.63	5.87	19.8	19.9	20.0
10/30	-	19.14	1218	9	6.11	6.17	6.22	18.9	19.0	19.0
11/13	-	14.38	1145	8	5.81	6.03	6.45	13.9	14.0	14.0
Station 17, RM 302.56, DO std = 4.0 mg/L										
03/28	7.81	8.39	1410	12	8.08	8.19	8.27	8.0	8.6	9.0
04/23	6.38	13.18	1249	14	6.25	6.29	6.37	13.1	13.2	13.4
05/22	5.24	19.24	1335	18	4.58	4.64	4.75	18.9	18.9	19.0
06/05	5.80	18.12	1502	12	5.04	5.23	5.40	17.8	17.9	18.0
06/19	3.62	21.20	1253	6	2.83	2.88	2.92	21.0	21.0	21.1
07/02	4.02	25.62	1232	22	5.18	5.45	6.00	25.4	25.4	25.4
07/10	4.79	23.53	1228	27	4.71	5.07	6.35	23.5	23.7	24.8
07/24	3.54	22.72	1248	24	3.88	3.96	4.11	22.5	22.6	23.0
07/31	4.25	22.62	1316	28	4.34	4.39	4.48	22.5	22.5	22.6
09/04	-	25.56	0958	10	5.91	5.96	5.99	25.4	22.5	25.6
09/05	-	25.87	1202	9	5.06	5.11	5.15	25.7	25.8	25.9
09/18	6.01	21.42	0856	10	4.99	5.11	5.17	21.2	21.2	21.3
09/19	5.73	21.37	1149	26	4.80	5.11	5.36	21.2	21.2	21.3
10/22	5.74	17.78	0849	14	5.95	6.46	6.77	17.4	17.7	18.0
10/23	-	18.51	0942	6	6.21	6.33	6.40	18.3	18.4	18.5
10/30	-	16.83	1156	9	6.35	6.38	6.40	16.0	16.7	17.0
11/13	6.35	11.32	1130	10	6.31	6.42	6.66	11.3	12.0	13.3
Station 18, RM 299.55, DO std = 4.0 mg/L										
03/28	8.36	8.53	1325	12	8.32	8.40	8.48	8.5	8.5	8.5
04/23	6.29	13.05	1318	18	6.14	6.25	6.34	13.0	13.1	13.2
05/22	4.47	18.65	1406	18	4.43	4.49	4.53	18.9	18.9	19.0
06/05	5.14	17.91	1439	4	5.10	5.12	5.14	17.8	17.8	17.8
06/19	-	-	1233	4	2.19	2.22	2.26	21.3	21.3	21.3
07/02	4.16	25.35	1125	18	4.46	4.86	5.49	25.3	25.3	25.5
07/10	4.70	24.03	1152	27	4.75	4.84	4.90	23.8	23.8	23.9
07/17	4.67	23.57	1207	22	4.68	4.83	4.95	23.4	23.4	23.4
07/24	3.45	22.64	1346	26	3.66	3.77	3.86	22.5	22.5	22.6
07/31	4.5	22.72	1241	27	4.41	4.49	4.59	22.4	22.5	22.6
09/05	5.68	25.92	1122	30	4.53	4.84	5.07	25.7	25.8	25.9
09/19	4.52	21.42	1122	30	4.69	4.94	5.13	21.3	21.4	21.6
10/23	5.64	18.51	0956	6	5.88	5.93	6.01	18.1	18.4	18.5
10/30	5.42	17.74	1138	9	5.77	5.87	5.94	17.5	17.6	17.6
11/13	6.31	11.76	1110	8	6.20	6.30	6.40	11.5	11.6	11.7

Table 12. Concluded

Date	Monitor reading		Begin time	N	Cross-sectional data					
	DO (mg/L)	Temp (°C)			DO (mg/L)			Temperature (°C)		
					Min	Mean	Max	Min	Mean	Max
Station 19, RM 296.19, DO std = 4.0 mg/L										
03/28			1220	12	7.95	8.09	8.18	8.1	8.2	8.2
04/23			1456	19	6.00	6.05	6.12	13.1	13.1	13.2
05/22			1436	19	4.27	4.36	4.53	19.1	19.1	19.2
06/05			1230	8	4.73	4.79	4.81	17.4	17.4	17.5
06/19			1144	12	1.43	1.50	1.60	21.4	21.4	21.5
07/02			1044	18	4.55	4.65	4.94	25.7	25.8	25.9
07/10			1102	28	4.45	4.58	4.71	23.9	24.0	24.1
07/17			1054	25	4.34	4.45	4.53	23.4	23.5	23.5
07/24			1059	23	3.47	3.58	3.72	22.3	22.4	22.4
07/31			1156	30	4.52	4.65	4.76	22.6	22.6	22.9
09/05			1044	30	4.58	4.81	4.95	23.3	26.2	26.4
09/19			0943	30	4.81	4.97	5.11	21.2	22.0	25.2
10/23			1025	7	5.88	5.95	6.02	18.1	18.2	18.3
10/30			1119	9	5.96	5.98	5.99	17.3	17.3	17.3
11/13			1049	8	5.96	5.98	6.00	12.2	12.3	12.3
Station 20, RM 295.34, DO std = 4.0 mg/L										
03/28			1155	14	7.89	8.03	8.18	8.3	8.3	8.4
04/23			1401	18	6.06	6.11	6.18	13.3	14.0	14.6
05/22			1455	17	4.20	4.28	4.40	19.3	20.3	24.3
06/05			1159	22	4.49	4.59	4.68	17.3	18.4	20.3
06/19			1121	10	1.25	1.36	1.53	21.9	23.2	25.4
07/02			1000	34	4.16	4.36	4.53	27.7	29.1	30.1
07/10			1032	31	4.34	4.55	4.65	24.7	27.2	28.4
07/17			1007	26	4.38	4.48	4.87	23.9	26.8	29.0
07/24			1030	26	3.49	3.57	3.62	22.4	23.7	27.1
07/31			1115	27	4.67	4.76	4.82	22.7	24.1	25.4
09/05			1012	30	4.33	4.59	4.78	26.3	29.6	31.2
09/19			1012	28	4.91	5.00	5.10	21.5	24.7	27.5
10/30			1104	9	5.80	5.84	5.87	17.3	19.3	21.9
11/13			1037	9	5.51	5.60	5.73	12.7	15.5	17.1
Station 21, RM 291.20, DO std = 4.0 mg/L										
03/28	7.30	12.80	1048	3	6.84	6.93	7.05	12.5	12.5	12.6
04/23	6.15	15.16	1431	6	5.90	5.92	5.94	15.1	15.3	15.4
05/22	4.20	20.78	1521	6	3.91	4.06	4.10	20.6	20.6	20.7
06/05	4.73	18.05	0953	7	4.79	4.81	4.84	17.9	17.9	18.0
06/19	1.03	22.55	1041	4	0.96	1.00	1.04	17.9	21.2	22.3
07/02	3.96	27.19	0930	10	4.00	4.13	4.34	26.9	26.9	27.1
07/10	4.03	27.19	0947	10	3.99	4.04	4.17	27.0	27.1	27.2
07/17	3.93	25.80	0922	10	4.03	4.20	4.23	25.6	25.7	25.7
07/24	3.10	23.39	0956	9	3.06	3.12	3.17	23.2	23.3	23.3
07/31	4.46	23.32	1041	12	4.43	4.47	4.51	23.2	23.3	23.3
09/05	5.23	28.07	0952	7	4.44	4.45	4.49	27.8	28.0	28.1
09/19	3.96	22.27	0838	10	4.56	4.63	4.75	22.0	22.0	22.1
10/23	5.34	18.44	1144	4	2.44	4.28	6.54	24.8	28.1	28.8
10/30	5.51	18.50	1034	13	5.53	5.57	5.74	18.2	18.2	18.3
11/13	5.75	15.22	1015	13	5.44	5.47	5.49	15.0	15.0	15.0

Note: N = number of values

**Table 13. Summary of Mean Cross-sectional
DO and Temperature Values by Date**

Station	River mile	Mean		Mean		Mean		Mean	
		DO (mg/L)	Temp (°C)	DO (mg/L)	Temp (°C)	DO (mg/L)	Temp (°C)	DO (mg/L)	Temp (°C)
		03/28/96		05/22/96		06/19/96		07/10/96	
1	328.10	11.40	5.3	9.58	19.2	7.48	19.9	7.32	21.9
2	327.69	12.69	4.4	9.54	18.8	7.17	19.9	7.72	21.9
3	326.62	13.89	4.0	10.64	18.7	6.69	20.5	7.00	22.2
4	325.31	12.61	4.8	4.80	19.5	0.52	21.1	6.88	22.7
5	322.66	15.33	4.5	6.80	20.6	6.03	22.0	7.58	23.2
6	321.32	7.81	10.1	6.74	19.4	5.32	19.4	6.85	22.7
7	320.71	7.49	9.9	5.09	18.6	4.70	19.6	6.85	22.9
8	318.51	8.54	8.1	4.79	18.8	3.89	20.6	6.76	22.9
9	318.08	9.00	7.7	5.55	18.7	3.83	20.6	5.82	22.2
10	317.62	8.59	7.5	6.95	18.2	4.21	20.7	6.17	22.3
11	316.00	8.07	7.2	7.70	17.7	4.20	21.2	6.30	22.8
12	311.55	8.88	6.9	3.62	17.9	2.47	21.2	6.13	23.3
13	310.70	8.86	6.9	4.19	18.2	2.66	21.2	7.25	23.6
14	307.13	9.47	7.2	3.97	19.2	2.03	21.3	7.04	23.8
15	303.63	8.42	7.0	4.25	18.9	1.97	21.1	7.65	24.0
16	304.69	7.70	10.0	4.80	18.8	3.53	20.7	4.35	23.6
17	302.56	8.19	8.6	4.64	18.9	2.88	21.0	5.07	23.7
18	299.55	8.40	8.5	4.49	18.9	2.22	21.3	4.84	23.8
19	296.19	8.09	8.2	4.36	19.1	1.50	21.4	4.58	24.0
20	295.34	8.03	8.3	4.28	20.3	1.36	23.2	4.55	27.2
21	291.20	6.93	12.5	4.06	20.6	1.00	21.2	4.04	27.1
		04/23/96		06/05/96		07/02/96		07/17/96	
1	328.10	10.84	11.5	8.04	18.6	7.48	22.4	7.24	22.8
2	327.69	13.04	11.1	8.39	18.4	7.15	22.9	7.12	22.9
3	326.62	10.70	11.3	8.20	18.2	6.27	23.4	6.60	22.9
4	325.31	4.32	12.5	6.12	18.2	5.89	24.1	6.02	23.5
5	322.66	8.27	13.2	6.30	18.4	6.07	25.5	7.03	23.9
6	321.32	6.58	13.4	5.76	16.7	6.32	23.4	6.11	22.9
7	320.71	5.51	13.4	5.51	17.0	5.41	23.4	-	-
8	318.51	6.24	12.4	5.10	16.4	4.72	23.9	-	-
9	318.08	6.14	12.0	5.05	16.5	4.27	23.8	4.94	23.5
10	317.62	7.16	12.1	5.44	16.8	5.37	23.8	5.82	23.7
11	316.00	8.12	12.1	5.25	16.9	4.89	24.2	5.33	23.7
12	311.55	6.29	12.0	5.00	17.4	3.94	24.6	4.78	23.8
13	310.70	6.62	12.1	5.46	17.6	4.97	24.8	5.83	23.8
14	307.13	6.43	12.3	5.27	17.7	4.56	25.3	5.47	23.6
15	303.63	5.86	12.7	4.84	17.8	5.09	25.9	-	-
16	304.69	6.68	13.4	4.83	18.0	5.59	25.6	-	-
17	302.56	6.29	13.2	5.23	17.9	5.45	25.4	-	-
18	299.55	6.25	13.1	5.12	17.8	4.86	25.3	4.83	23.4
19	296.19	6.05	13.1	4.79	17.4	4.65	25.8	4.45	23.5
20	295.34	6.11	14.0	4.59	18.4	4.36	29.1	4.48	26.8
21	291.20	5.92	15.3	4.81	17.9	4.13	26.9	4.20	25.7

Table 13. Concluded

Station	River mile	Mean		Mean		Mean		Mean	
		DO (mg/L)	Temp (°C)	DO (mg/L)	Temp (°C)	DO (mg/L)	Temp (°C)	DO (mg/L)	Temp (°C)
		07/24/96		09/04-05/96		10/22-23/96		11/13/96	
1	328.10	6.31	23.5	7.23	24.2	9.27	14.9	8.91	9.2
2	327.69	6.13	23.5	7.59	24.2	9.26	14.9	9.27	8.6
3	326.62	5.20	23.2	7.14	24.0	8.99	14.7	9.60	7.3
4	325.31	5.28	23.6	6.88	24.2	8.22	15.0	8.44	6.6
5	322.66	4.61	23.8	7.41	24.4	8.24	14.6	9.31	5.4
6	321.32	4.84	22.6	6.41	24.0	8.25	16.8	6.92	12.2
7	320.71	4.35	23.1	5.60	24.4	7.87	16.8	6.59	12.9
8	318.51	-	-	5.60	24.1	7.47	16.1	6.92	10.8
9	318.08	3.35	21.6	5.80	24.1	7.45	16.1	7.05	10.7
10	317.62	3.90	21.7	5.79	24.2	7.96	16.1	7.12	10.0
11	316.00	3.85	21.9	5.87	24.4	7.21	15.7	6.99	9.4
12	311.55	3.46	22.3	5.36	24.2	7.38	15.4	6.60	8.2
13	310.70	3.96	22.3	5.98	24.5	7.69	15.4	6.48	8.1
14	307.13	3.97	22.3	5.37	24.1	7.55	15.3	6.24	7.6
15	303.63	3.78	22.1	5.59	24.3	7.17	14.9	6.02	8.5
16	304.69	3.82	23.8	-	-	5.64	19.9	6.03	14.0
17	302.56	3.96	22.6	5.96	25.5	6.33	18.4	6.42	12.0
18	299.55	3.77	22.5	4.84	25.8	5.93	18.4	6.30	11.6
19	296.19	3.58	22.4	4.81	26.2	5.95	18.2	5.98	12.3
20	295.34	3.57	23.7	4.59	29.6	-	-	5.60	15.5
21	291.20	3.12	23.3	4.49	28.0	4.47	28.1	5.47	15.0
		07/31/96		09/18-19/96		10/30/96			
1	328.10	7.05	22.6	6.70	21.9	8.96	14.5		
2	327.69	7.70	22.8	7.69	21.9	9.37	14.2		
3	326.62	7.06	23.0	7.59	21.7	9.21	13.8		
4	325.31	4.53	22.9	7.54	21.3	8.65	13.4		
5	322.66	4.78	23.4	7.70	21.2	8.93	13.1		
6	321.32	5.77	22.3	6.74	21.6	7.47	15.2		
7	320.71	5.35	22.4	6.68	21.8	6.91	15.3		
8	318.51	4.64	21.6	6.00	21.3	6.55	14.2		
9	318.08	4.22	21.0	5.70	21.1	6.22	14.2		
10	317.62	4.67	21.2	6.10	21.1	6.72	14.3		
11	316.00	4.37	21.1	5.60	21.0	6.29	14.4		
12	311.55	3.76	21.5	5.90	20.6	7.31	14.1		
13	310.70	3.91	21.6	5.80	20.2	7.51	14.0		
14	307.13	3.15	21.6	5.20	20.0	7.36	13.8		
15	303.63	3.85	21.8	5.62	21.5	7.10	14.5		
16	304.69	4.04	23.7	5.17	21.9	6.17	19.0		
17	302.56	4.39	22.5	5.11	21.2	6.38	16.7		
18	299.55	4.49	22.5	4.94	21.4	5.87	17.6		
19	296.19	4.65	22.6	4.97	22.0	5.98	17.3		
20	295.34	4.76	24.1	5.00	24.7	5.84	19.3		
21	291.20	4.47	23.3	4.63	22.0	5.57	18.2		

Table 14. Unweighted and Weighted DO Means for Cross-sectional Measurements with Worst-Case Conditions, 1996

a. Data

<i>Station</i>	<i>Date</i>	<i>Mean DO (mg/L)</i>	
		<i>Unweighted</i>	<i>Weighted</i>
2	6/05	8.39	8.28
6	4/23	6.58	6.65
6	5/22	6.74	6.75
7	5/22	5.09	4.92
10	5/22	6.95	7.15
10	7/24	3.90	3.79
10	7/31	4.67	4.68
13	7/10	7.25	7.06
14	6/19	2.03	1.76
15	7/10	7.65	7.39

b. Paired *t*-test analysis

<i>Group</i>	<i>Mean</i>	<i>Standard deviation</i>	<i>Difference in means</i>
Unweighted	5.925	1.958	
Weighted	5.847	2.004	0.078

Result from paired *t*-test analysis:

Computed *t* value = 1.591

t @ 9 degrees freedom; 95% confidence level = 2.262

Note: Accept the hypothesis that the unweighted and weighted means are equal at the 95% confidence level.

Table 15. Statistical Summary Comparing 1996 Continuous Monitoring DO Values with Mean Cross-sectional DO Values Using Paired *t*-test

Station	No. of pairs	Mean (mg/L)		Differences		Standard error "means of paired differences"	t-value		Hypothesis	
		X-section (\bar{X}_1)	Monitor (\bar{X}_2)	$\bar{X}_1 - \bar{X}_2$	Means of paired differences		Calculated	@ P = 0.05	$\bar{X}_1 - \bar{X}_2$ @ P = 0.05	Accept
1	11	8.226	7.907	0.319	0.884	0.267	1.197	2.228	✓	
2	11	8.364	7.932	0.432	0.751	0.226	1.907	2.228	✓	
6	13	6.572	6.805	-0.232	0.768	0.213	1.091	2.179	✓	
7	13	5.865	5.835	0.030	0.915	0.254	0.118	2.179	✓	
9	13	5.626	5.728	-0.102	0.644	0.166	0.613	2.179	✓	
10	13	6.024	5.474	0.550	0.843	0.234	2.351	2.179		✓
12	15	5.392	5.423	-0.031	0.543	0.140	0.219	2.145	✓	
13	14	5.580	5.846	-0.266	0.409	0.109	2.430	2.160		✓
14	14	5.469	5.439	0.031	0.497	0.133	0.231	2.160	✓	
15	16	5.436	5.216	0.220	0.528	0.132	1.666	2.131	✓	
16	11	5.060	4.632	0.428	0.796	0.240	1.784	2.228	✓	
17	13	5.323	5.329	-0.006	0.672	0.186	0.033	2.179	✓	
18	14	5.352	5.238	0.114	0.354	0.095	1.208	2.160	✓	
21	15	4.472	4.579	-0.107	0.415	0.107	0.995	2.145	✓	

Note: The X-section at station 21 is the average of 2-foot measurement intervals on the vertical; monitor is mean of the near surface, mid-depth, and bottom monitors.

Table 16. Summary of Kruskal-Wallis, Rank-Order One-Way ANOVA Comparing Monitor DO Concentrations Recorded at Lockport Lock and Dam, 1996

Location	ANOVA statistics				Events compared	Multiple comparison (Dunn method)				
	No. of values	Percentile				Rank differences	Q-value		Hypothesis	
		25	50 (\tilde{X})	75			Calculated	@P = 0.05 & 2df	$\tilde{X}_i = \tilde{X}_j$	Accept
21t	4102	3.48	4.11	5.24	21t/21m	847	10.08	1.95		✓
21m	4102	3.65	4.40	6.01	21t/21b	1159	3.98	1.95		✓
21b	4102	3.84	4.75	5.89	21m/21b	312	14.78	1.95		✓

Result of Kruskal-Wallis, Rank-Order One-Way ANOVA

Computed *H*-value: 234

H-value @ *P* = 0.05: 4.75

Reject hypothesis: $\tilde{X}_t = \tilde{X}_m = \tilde{X}_b$

Notes: t = near the surface, m = mid-depth, and b = bottom.

**Table 17. Percentage of Time DO Values Are Less than a Specified Value by Period
Based on Hourly Data Using Frequency Distribution Curves**

Station	Waterway	River	DO std. (mg/L)	Percentage of time less than														
				DO concentration (mg/L)							DO concentration (mg/L)							
				Period 1 (816 hr, 03/16-04/18/96)							Period 2 (1008 hr, 04/19-05/30/96)							
				1.0	2.0	3.0	4.0	5.0	6.0	7.0	1.0	2.0	3.0	4.0	5.0	6.0	7.0	
1	CR	328.10	5.0														<0.01	
2	"	237.69	5.0														<0.01	
6	LCR	321.32	4.0								0.27	3.44	0.78	12.68	22.82	49.73	77.99	
7	"	320.71	4.0									95.82		2.12	12.72	53.93	97.23	
9	CSC	318.08	3.0								0.34	7.85		0.80	14.00	33.66	75.27	
10	"	317.62	3.0								4.63	13.91		0.93	22.05	69.64	93.72	
12	"	311.55	3.0					0.18			7.70	19.89		7.74	35.63	62.89	92.41	
13	"	310.70	3.0											1.61	9.26	30.42	80.37	
14	"	307.15	3.0								0.26	8.71		1.21	9.81	18.78	72.26	
15	"	303.63	3.0								0.08	9.62		8.80	24.58	64.81	93.08	
16	CSSC	304.69	4.0			0.12	0.47				3.59	27.82		4.11	22.53	56.08	82.42	
17	"	302.56	4.0				2.44				25.92	67.20		3.02	10.70	58.30	95.75	
18	"	299.55	4.0									28.56		2.50	21.40	70.80	96.80	
21t	"	291.20	4.0								1.72	21.96		0.69	9.82	34.84	86.31	
21m	"	"	4.0								7.62	31.82		0.42	3.48	26.64	51.79	
21b	"	"	4.0								4.03	40.37		0.26	6.86	24.71	62.75	
				Period 3 (816 hr, 05/31-07/03/96)							Period 4 (2016 hr, 07/04-09/25/96)							
1	CR	328.10	5.0														9.80	45.57
2	"	237.69	5.0														16.46	59.15
6	LCR	321.32	4.0								2.45	23.28		1.06	7.48	34.17	76.50	
7	"	320.71	4.0								57.58	87.79		4.13	10.84	46.11	79.96	
9	CSC	318.08	3.0								86.12	99.88		9.10	18.71	78.63	99.04	
10	"	317.62	3.0								91.54	99.94		6.12	37.93	89.66	99.66	
12	"	311.55	3.0								96.04	99.94		2.06	15.68	46.27	89.66	
13	"	310.70	3.0								88.23	99.00		1.10	12.80	42.68	86.83	
14	"	307.15	3.0								93.50	99.50		1.66	8.19	35.29	65.01	
15	"	303.63	3.0								98.75	99.92		1.75	12.22	40.93	88.28	
16	CSSC	304.69	4.0								85.27	99.94		4.02	22.24	63.60	97.91	
17	"	302.56	4.0								99.46	99.94		12.23	30.37	78.07	97.36	
18	"	299.55	4.0								90.55	99.94		5.32	31.11	80.27	96.93	
21t	"	291.20	4.0								95.61	99.89		0.86	32.24	86.24	99.96	
21m	"	"	4.0								99.94	99.94		1.53	17.02	71.73	99.97	
21b	"	"	4.0								99.94	99.94		3.09	15.03	69.03	99.96	
											81.74	99.94		2.65	13.67	51.67	91.52	

Table 17. Concluded.

Station	Waterway	River mile	DO std. (mg/L)	Percentage of time less than						
				DO concentration (mg/L)			DO concentration (mg/L)			
				Period 5 (864 hr. 09/26-10/31/96)						
				1.0	2.0	3.0	4.0	5.0	6.0	7.0
1	CR	328.10	5.0						2.00	29.03
2	"	237.69	5.0						4.94	64.37
6	LCR	321.32	4.0						1.80	18.85
7	"	320.71	4.0						1.65	22.04
9	CSC	318.08	3.0						5.35	26.45
10	"	317.62	3.0						2.19	18.77
12	"	311.55	3.0						6.88	48.43
13	"	310.70	3.0						5.31	28.04
14	"	307.15	3.0						3.83	7.64
15	"	303.63	3.0						5.33	29.93
16	CSSC	304.69	4.0	0.99	1.42	1.82	5.31	28.04	75.66	99.50
17	"	302.56	4.0		0.29	1.59	3.83	7.64	63.14	99.86
18	"	299.55	4.0		0.34	1.30	5.33	29.93	89.79	99.94
21t	"	291.20	4.0		1.16	2.32	15.49	67.55	99.44	99.94
21m	"	"	4.0				3.13	17.19	84.79	99.81
21b	"	"	4.0				2.28	18.77	90.11	99.81
				Period 6 (456 hr. 11/01-11/19/96)						
				1.0	2.0	3.0	4.0	5.0	6.0	7.0
							0.13			
								0.14	2.36	22.48
								0.41	12.53	53.73
									12.06	68.86
									12.26	77.19
									25.00	50.44
									45.82	73.19
									5.70	89.96
										50.00
										1.23
										32.58
										91.81
										6.14
										41.94
										96.93
										19.30
										67.98
										99.89
										44.65
										92.84
										8.13
										56.04
										98.46

				Period 1-6 (5976 hr. 03/16-11/19/96)						
				9.80	4.48	27.03	45.68	48.40	80.89	80.76
1	CR	328.10	5.0							
2	"	237.69	5.0							
6	LCR	321.32	4.0	0.02	0.39	1.50	4.08	9.66	27.03	19.93
7	"	320.71	4.0	0.39	0.88	2.01	5.50	16.03	45.68	56.43
9	CSC	318.08	3.0							
10	"	317.62	3.0							
12	"	311.55	3.0	0.02						
13	"	310.70	3.0							
14	"	307.15	3.0							
15	"	303.63	3.0							
16	CSSC	304.69	4.0	1.35	2.75	7.86	23.32	56.73	75.85	86.58
17	"	302.56	4.0							
18	"	299.55	4.0							
21t	"	291.20	4.0	0.14	1.35	7.93	32.76	61.47	80.67	88.70
21m	"	"	4.0							
21b	"	"	4.0	0.30	1.81	7.82	28.50	52.88	75.90	92.39

Notes: CR = Calumet River, LCR = Little Calumet River, CSC = Cal-Sag Channel, and CSSC = Chicago Sanitary and Ship Canal, t = near surface, m = mid-depth, and b = bottom.

Table 18. Percentage of Time DO Values Are Less than a Specified Value by Period Based on Hourly Data Using z-table Statistics

Station	Waterway	River mile	DO std. (mg/L)	Percentage of time less than													
				DO concentration (mg/L)						DO concentration (mg/L)							
				1.0	2.0	3.0	4.0	5.0	7.0	1.0	2.0	3.0	4.0	5.0	6.0	7.0	
				Period 1 (816 hr, 03/16-04/18/96)						Period 2 (1008 hr, 04/19-05/30/96)							
1	CR	378.10	5.0	<0.02	<0.02	<0.02	<0.02	<0.02	<0.02	<0.02	<0.02	<0.02	<0.02	<0.02	<0.02	<0.02	3.09
2	"	237.69	5.0	<0.02	<0.02	<0.02	<0.02	<0.02	<0.02	<0.02	<0.02	<0.02	<0.02	<0.02	<0.02	<0.02	2.56
6	LCR	321.32	4.0	<0.02	0.07	<0.02	0.07	<0.02	0.30	<0.02	0.30	<0.02	0.96	27.43	59.59	78.23	78.23
7	"	320.71	4.0	<0.02	0.30	<0.02	0.47	<0.02	0.721	<0.02	0.47	<0.02	1.50	10.75	37.83	72.91	72.91
9	CSC	318.08	3.0	<0.02	0.47	<0.02	0.721	<0.02	1.58	<0.02	1.58	<0.02	3.07	23.58	67.00	94.41	94.41
10	"	317.62	3.0	<0.02	1.58	<0.02	1.58	<0.02	15.15	<0.02	15.15	<0.02	3.07	23.58	67.00	94.41	94.41
12	"	311.55	3.0	<0.02	4.09	<0.02	4.09	<0.02	25.14	<0.02	25.14	<0.02	8.08	31.56	66.64	90.99	90.99
13	"	310.70	3.0	<0.02	0.13	<0.02	0.13	<0.02	2.68	<0.02	2.68	<0.02	0.71	8.38	37.83	77.64	77.64
14	"	307.15	3.0	<0.02	0.55	<0.02	0.55	<0.02	9.18	<0.02	9.18	<0.02	0.24	4.46	28.43	70.88	70.88
15	"	303.63	3.0	<0.02	1.07	<0.02	1.07	<0.02	16.35	<0.02	16.35	<0.02	5.94	27.76	64.80	91.15	91.15
16	CSSC	304.69	4.0	<0.02	3.07	<0.02	3.07	<0.02	25.14	<0.02	25.14	<0.02	4.85	55.17	84.85	97.32	97.32
17	"	302.56	4.0	<0.02	24.51	<0.02	24.51	<0.02	77.34	<0.02	77.34	<0.02	1.02	14.69	58.71	93.06	93.06
18	"	299.55	4.0	<0.02	0.78	<0.02	0.78	<0.02	21.48	<0.02	21.48	<0.02	0.05	2.28	24.20	72.57	72.57
21t	"	291.20	4.0	<0.02	1.39	<0.02	1.39	<0.02	22.66	<0.02	22.66	<0.02	0.37	7.21	40.52	83.40	83.40
21m	"	"	4.0	<0.02	3.92	<0.02	3.92	<0.02	38.21	<0.02	38.21	<0.02	0.47	5.05	24.83	61.03	61.03
21b	"	"	4.0	<0.02	4.46	<0.02	4.46	<0.02	42.86	<0.02	42.86	<0.02	0.14	3.36	25.14	68.79	68.79
				Period 3 (816 hr, 05/31-07/03/96)						Period 4 (2016 hr, 07/04-09/25/96)							
1	CR	378.10	5.0	<0.02	<0.02	<0.02	<0.02	<0.02	<0.02	<0.02	<0.02	<0.02	<0.02	<0.02	<0.02	<0.02	5.05
2	"	237.69	5.0	<0.02	<0.02	<0.02	<0.02	<0.02	<0.02	<0.02	<0.02	<0.02	<0.02	<0.02	<0.02	<0.02	5.05
6	LCR	321.32	4.0	<0.02	0.04	<0.02	0.04	<0.02	97.78	<0.02	97.78	<0.02	0.09	2.62	22.06	65.54	65.54
7	"	320.71	4.0	<0.02	56.75	<0.02	56.75	<0.02	84.85	<0.02	84.85	<0.02	2.02	12.92	41.68	76.11	76.11
9	CSC	318.08	3.0	<0.02	39.74	<0.02	39.74	<0.02	98.78	<0.02	98.78	<0.02	1.54	7.78	24.83	52.79	52.79
10	"	317.62	3.0	<0.02	88.49	<0.02	88.49	<0.02	98.93	<0.02	98.93	<0.02	0.27	5.94	36.69	81.06	81.06
12	"	311.55	3.0	<0.02	94.84	<0.02	94.84	<0.02	99.95	<0.02	99.95	<0.02	1.29	13.57	51.20	87.90	87.90
13	"	310.70	3.0	<0.02	87.49	<0.02	87.49	<0.02	98.30	<0.02	98.30	<0.02	0.94	11.51	47.61	86.21	86.21
14	"	307.15	3.0	<0.02	68.44	<0.02	68.44	<0.02	94.18	<0.02	94.18	<0.02	0.84	8.08	33.72	71.57	71.57
15	"	303.63	3.0	<0.02	83.40	<0.02	83.40	<0.02	97.38	<0.02	97.38	<0.02	0.87	10.75	46.02	85.08	85.08
16	CSSC	304.69	4.0	<0.02	87.08	<0.02	87.08	<0.02	98.12	<0.02	98.12	<0.02	2.39	22.96	69.15	95.82	95.82
17	"	302.56	4.0	<0.02	99.18	<0.02	99.18	<0.02	>99.98	<0.02	>99.98	<0.02	14.46	43.86	75.80	94.29	94.29
18	"	299.55	4.0	<0.02	85.99	<0.02	85.99	<0.02	99.22	<0.02	99.22	<0.02	5.37	33.72	78.23	97.56	97.56
21t	"	291.20	4.0	<0.02	98.71	<0.02	98.71	<0.02	>99.98	<0.02	>99.98	<0.02	3.36	34.09	84.13	99.25	>99.98
21m	"	"	4.0	<0.02	99.20	<0.02	99.20	<0.02	>99.98	<0.02	>99.98	<0.02	17.62	74.22	98.68	>99.98	>99.98
21b	"	"	4.0	<0.02	99.83	<0.02	99.83	<0.02	>99.98	<0.02	>99.98	<0.02	18.14	68.08	96.71	99.93	>99.98
				0.28	3.29	18.14	51.20	83.15	97.13	99.77	99.77	1.19	14.01	54.38	90.15	99.32	>99.98

Table 18. Concluded

Station	Waterway	River mile	DO std. (mg/L)	Percentage of time less than												
				DO concentration (mg/L)						DO concentration (mg/L)						
				1.0	2.0	3.0	4.0	5.0	6.0	7.0	1.0	2.0	3.0	4.0	5.0	6.0
				Period 5 (864 hr, 09/26-10/31)						Period 6 (456 hr, 11/01-11/19/96)						
1	CR	378.10	5.0	<0.02	<0.02	<0.02	<0.02	<0.02	<0.02	<0.02	<0.02	<0.02	<0.02	<0.02	<0.02	<0.02
2	"	237.69	5.0	<0.02	<0.02	<0.02	<0.02	<0.02	<0.02	<0.02	<0.02	<0.02	<0.02	<0.02	<0.02	<0.02
6	LCR	321.32	4.0	1.29	32.64	60.64	78.81	80.78	79.39	65.91	84.61	90.82	95.25	96.78	99.34	99.92
7	"	320.71	4.0	4.55	60.64	78.81	80.78	79.39	65.91	84.61	90.82	95.25	96.78	99.34	99.92	99.96
9	CSC	318.08	3.0	<0.02	1.13	22.96	78.81	80.78	79.39	65.91	84.61	90.82	95.25	96.78	99.34	99.92
10	"	317.62	3.0	<0.02	1.43	25.46	80.78	80.78	79.39	65.91	84.61	90.82	95.25	96.78	99.34	99.92
12	"	311.55	3.0	<0.02	3.67	31.56	79.39	80.78	79.39	65.91	84.61	90.82	95.25	96.78	99.34	99.92
13	"	310.70	3.0	<0.02	1.22	17.88	65.91	80.78	79.39	65.91	84.61	90.82	95.25	96.78	99.34	99.92
14	"	307.15	3.0	<0.02	0.29	19.22	84.61	80.78	79.39	65.91	84.61	90.82	95.25	96.78	99.34	99.92
15	"	303.63	3.0	<0.02	0.31	8.38	90.82	80.78	79.39	65.91	84.61	90.82	95.25	96.78	99.34	99.92
16	CSSC	304.69	4.0	<0.02	0.60	7.21	95.25	96.78	99.34	99.92	99.92	99.92	99.92	99.92	99.92	99.92
17	"	302.56	4.0	<0.02	0.64	14.92	96.78	99.34	99.92	99.92	99.92	99.92	99.92	99.92	99.92	99.92
18	"	299.55	4.0	<0.02	0.08	36.69	99.34	99.92	99.92	99.92	99.92	99.92	99.92	99.92	99.92	99.92
21t	"	291.20	4.0	<0.02	1.19	18.14	99.92	99.92	99.92	99.92	99.92	99.92	99.92	99.92	99.92	99.92
21m	"	"	4.0	<0.02	1.02	23.27	99.92	99.92	99.92	99.92	99.92	99.92	99.92	99.92	99.92	99.92
21b	"	"	4.0	<0.02	0.51	27.76	99.92	99.92	99.92	99.92	99.92	99.92	99.92	99.92	99.92	99.92
				Period 1-6 (5976 hr, 03/16-11/19/96)						Period 1-6 (5976 hr, 03/16-11/19/96)						
1	CR	378.10	5.0	<0.02	0.11	0.94	5.05	17.36	20.33	20.33	20.33	20.33	20.33	20.33	20.33	20.33
2	"	237.69	5.0	0.28	1.13	3.59	9.34	20.33	20.33	20.33	20.33	20.33	20.33	20.33	20.33	20.33
6	LCR	321.32	4.0	<0.02	0.02	0.31	10.56	30.85	59.87	59.87	59.87	59.87	59.87	59.87	59.87	59.87
7	"	320.71	4.0	<0.02	0.03	0.47	19.77	50.80	81.33	81.33	81.33	81.33	81.33	81.33	81.33	81.33
9	CSC	318.08	3.0	<0.02	0.13	1.16	21.19	47.21	74.54	74.54	74.54	74.54	74.54	74.54	74.54	74.54
10	"	317.62	3.0	<0.02	0.14	1.29	24.20	52.79	79.67	79.67	79.67	79.67	79.67	79.67	79.67	79.67
12	"	311.55	3.0	<0.02	0.23	1.83	28.10	56.75	82.38	82.38	82.38	82.38	82.38	82.38	82.38	82.38
13	"	310.70	3.0	<0.02	0.05	0.62	18.67	46.41	76.42	76.42	76.42	76.42	76.42	76.42	76.42	76.42
14	"	307.15	3.0	<0.02	0.23	1.66	24.51	51.20	77.34	77.34	77.34	77.34	77.34	77.34	77.34	77.34
15	"	303.63	3.0	0.05	0.48	3.07	32.64	60.26	83.65	83.65	83.65	83.65	83.65	83.65	83.65	83.65
16	CSSC	304.69	4.0	0.05	2.87	10.38	50.40	74.22	90.15	90.15	90.15	90.15	90.15	90.15	90.15	90.15
17	"	302.56	4.0	<0.02	0.16	1.92	37.45	71.23	92.51	92.51	92.51	92.51	92.51	92.51	92.51	92.51
18	"	299.55	4.0	0.03	0.47	3.51	40.90	71.23	91.15	91.15	91.15	91.15	91.15	91.15	91.15	91.15
21t	"	291.20	4.0	0.57	3.07	11.51	55.17	78.52	92.79	92.79	92.79	92.79	92.79	92.79	92.79	92.79
21m	"	"	4.0	0.57	2.94	10.38	50.00	73.57	89.62	89.62	89.62	89.62	89.62	89.62	89.62	89.62
21b	"	"	4.0	0.29	1.97	8.85	52.39	77.64	92.92	92.92	92.92	92.92	92.92	92.92	92.92	92.92

Notes: CR = Calumet River, LCR = Little Calumet River, CSC = Cal-Sag Channel, and CSSC = Chicago Sanitary and Ship Canal, t = near surface, m = mid-depth, and b = bottom.

Table 19. Percentage of Occurrence When DO Values Were Less than 3.0 mg/L at Selected Stations, 1996

Station	River mile	Percent of time DO values are less than 3.0 mg/L on an hourly basis for period						
		1	2	3	4	5	6	1-6
15	303.63	0.00	0.00	4.90	4.02	0.00	0.00	2.00
16	304.69	0.00	4.11	13.30	12.23	1.82	0.00	7.86
5								
17	302.56	0.00	0.00	0.66	5.27	1.59	0.00	2.05
12	311.55	0.00	0.53	4.26	1.10	0.00	0.00	1.07
4								
13	310.70	0.00	0.00	1.36	1.66	0.00	0.00	0.78
9	318.08	0.00	0.00	1.26	0.00	0.00	0.00	0.18
3								
10	317.62	0.00	0.00	0.37	2.06	0.00	0.00	0.66

Note: Stations 3-5 are SEPA stations.

Table 20. Seasonal DO Summaries at SEPA Station Intakes for Hourly Readings, 1996

Location			Hourly DO (mg/L) for seasonal periods						
SEPA station intake	River mile	Hourly DO statistic	1 03/16- 04/18	2 04/19- 05/30	3 05/31- 07/03	4 07/04- 09/25	5 09/26- 10/31	6 11/01- 11/19	1-6 03/16- 11/19
1	328.10	minimum	7.71	7.47	6.55	5.10	7.05	8.79	5.10
		mean	10.46	8.46	7.54	6.96	8.01	9.45	8.33
		maximum	12.66	9.95	8.29	8.39	8.47	10.30	12.66
2	321.32	minimum	5.76	1.15	1.56	0.88	5.64	6.25	0.88
		mean	8.29	5.87	5.80	6.23	7.25	7.35	6.67
		maximum	10.38	8.62	9.32	8.93	8.76	8.21	10.38
3	318.08	minimum	5.94	3.59	2.48	3.15	4.68	4.79	2.48
		mean	8.28	6.34	4.91	5.28	6.48	6.71	6.10
		maximum	10.78	9.18	6.59	7.62	8.13	8.08	10.78
4	311.55	minimum	4.65	2.87	0.92	2.36	4.31	5.39	0.92
		mean	7.62	5.53	4.81	5.05	6.37	6.84	5.77
		maximum	9.46	8.47	8.73	7.65	8.40	8.15	9.46
5	303.63	minimum	5.97	3.04	1.39	2.30	3.93	5.60	1.39
		mean	7.74	5.61	4.81	4.60	6.02	6.96	5.63
		maximum	10.03	8.11	7.01	7.61	8.27	8.48	10.03

Table 21. Percent of Time DO Concentrations Are Less than Stream Standard at SEPA Station Intakes on Hourly Readings, 1996

<i>Location</i>			<i>Percent of time hourly DO Values are less than the DO standard for seasonal periods</i>						
<i>SEPA station intake</i>	<i>River mile</i>	<i>DO std. (mg/L)</i>	<i>1</i>	<i>2</i>	<i>3</i>	<i>4</i>	<i>5</i>	<i>6</i>	<i>1-6</i>
			<i>03/16-04/18</i>	<i>04/19-05/30</i>	<i>05/31-07/03</i>	<i>07/04-09/25</i>	<i>09/26-10/31</i>	<i>11/01-11/19</i>	<i>03/16-11/19</i>
1	328.10	5.00	0.00	0.00	0.00	0.00	0.04	0.00	0.47
2	321.32	4.00	0.00	11.18	5.92	3.08	0.00	0.00	3.21
3	318.08	3.00	0.00	0.00	1.53	0.00	0.00	0.00	0.67
4	311.50	3.00	0.00	0.79	4.14	1.02	0.01	0.00	1.45
5	303.63	3.00	0.00	0.00	4.59	3.21	0.01	0.00	2.54

Table 22. In-Stream DO Concentrations, at Intake and Below SEPA Stations, Including Computed Completely Mixed Values for Cross-sectional DO Measurements Made, 1996

		<i>DO concentration (mg/L) at SEPA station</i>														
		<i>1</i>			<i>2</i>			<i>3</i>			<i>4</i>			<i>5</i>		
<i>Period</i>	<i>Date</i>	<i>In</i>	<i>Below</i>		<i>In</i>	<i>Below</i>		<i>In</i>	<i>Below</i>		<i>In</i>	<i>Below</i>		<i>In</i>	<i>Below</i>	
		<i>(1)</i>	<i>(2)</i>	<i>Mixed</i>	<i>(6)</i>	<i>(7)</i>	<i>Mixed</i>	<i>(9)</i>	<i>(10)</i>	<i>Mixed</i>	<i>(12)</i>	<i>(13)</i>	<i>Mixed</i>	<i>(15)</i>	<i>(17)</i>	<i>Mixed</i>
2	04/23	10.84	13.04	-	6.58	5.51	6.82	6.14	7.16	6.89	6.29	6.62	7.09	5.86	6.29	6.67
	05/22	9.58	9.54	9.30	6.74	5.09	6.96	5.55	6.95	6.46	3.62	4.19	5.08	4.25	4.64	5.12
3	06/05	8.04	8.39	8.57	5.76	5.51	5.92	5.05	5.44	5.57	5.00	5.46	6.05	4.84	5.23	5.11
	06/19	7.48	7.17	8.79	5.32	4.70	5.51	3.83	4.21	5.26	2.47	2.66	4.27	1.97	2.88	3.59
4	07/02	7.48	7.15	7.44	6.32	5.41	6.47	4.27	5.37	5.74	3.94	4.97	5.31	5.09	5.45	5.92
	07/10	7.32	7.72	7.57	6.85	6.85	6.92	5.82	6.17	6.60	6.13	7.25	7.06	7.65	5.07	5.52
	07/17	7.24	7.12	7.75	6.11	-	-	4.94	5.82	5.83	4.78	5.83	6.65	-	-	-
	07/24	6.31	6.13	6.77	4.84	4.35	4.98	3.35	3.90	4.47	3.46	3.96	4.54	3.78	3.96	3.98
	07/31	7.05	7.70	7.27	5.77	5.35	5.85	4.22	4.67	5.01	3.76	3.91	4.60	3.85	4.39	4.49
	09/04	7.23	7.59	7.46	6.41	5.60	6.50	5.80	5.79	6.13	5.36	5.98	6.19	5.59	5.96	5.17
	09/05	-	-	-	-	-	-	-	-	-	-	-	-	5.30	5.11	5.14
	09/18	6.70	7.69	7.15	6.74	6.68	6.83	5.70	6.10	6.10	5.90	5.80	6.27	5.12	5.11	4.92
	09/19	-	-	-	-	-	-	-	-	-	-	-	-	5.62	5.11	5.44
	5	10/22	9.26	9.24	9.62	8.23	7.87	8.26	7.45	7.96	-	7.38	7.69	8.23	6.71	6.46
10/23		-	-	-	-	-	-	-	-	-	-	-	-	7.17	6.33	6.21
10/30		8.96	9.37	-	7.47	6.91	-	6.22	6.72	6.66	7.31	7.51	7.73	7.10	6.38	-
Mean *	7.47	7.68	7.81	6.08	5.50	6.22	4.84	5.40	5.70	4.40	4.91	5.49	4.68	4.74	4.87	

Notes: Numbers in parentheses indicate monitoring stations; In = intake; Mixed = computed completely mixed.

* For nine dates having three values common for all stations.

Table 23. Comparison of DO Concentrations at SEPA Station Intakes with and without Upstream SEPA Station Operations for Cross-sectional DO Measurements Made, 1996

		<i>Mean cross-sectional DO concentrations (mg/L) at intakes of SEPA stations</i>							
<i>Period</i>	<i>Date</i>	<i>SEPA station 2</i>		<i>SEPA station 3</i>		<i>SEPA station 4</i>		<i>SEPA station 5</i>	
		<i>w-1</i>	<i>w/o-1</i>	<i>w-1,2</i>	<i>w/o-2</i>	<i>w-1,2,3</i>	<i>w/o-3</i>	<i>w-1,2,3,4</i>	<i>w/o-4</i>
2	04/23	6.63	-	6.14	5.90	6.29	5.53	5.86	5.05
	05/22	6.78	5.80	5.63	5.42	3.63	2.74	4.25	2.80
3	06/05	5.80	5.28	5.06	4.90	5.01	4.49	4.84	3.79
	06/19	5.35	4.04	3.83	3.64	2.48	1.06	1.99	0.19
	07/02	6.37	6.36	4.28	4.14	3.94	2.48	5.14	3.77
4	07/10	6.89	6.64	5.83	5.77	6.18	5.40	7.73	6.82
	07/17	6.12	5.61	4.94	-	4.78	3.89	-	-
	07/24	4.93	4.47	3.35	3.21	3.46	2.34	3.78	2.70
	07/31	5.78	5.56	4.22	4.14	3.76	2.97	3.86	3.02
	09/04	6.46	6.24	5.80	5.71	5.37	5.04	5.59	4.76
	09/05	-	-	-	-	-	-	5.30	-
	09/18	6.76	6.32	5.70	5.61	5.91	5.51	5.12	4.76
	09/19	-	-	-	-	-	-	5.62	-
	10/22	8.25	7.89	7.45	7.42	7.38	-	6.72	5.83
5	10/23	-	-	-	-	-	-	7.17	-
	10/30	7.47	-	6.23	-	7.31	6.88	7.11	6.69
Mean *		6.12	5.63	4.86	4.73	4.42	3.56	4.70	3.62

Notes: All numbers in column headings indicate SEPA stations; w - with, w/o - without

* For the nine dates having two values common for all locations

FIGURES

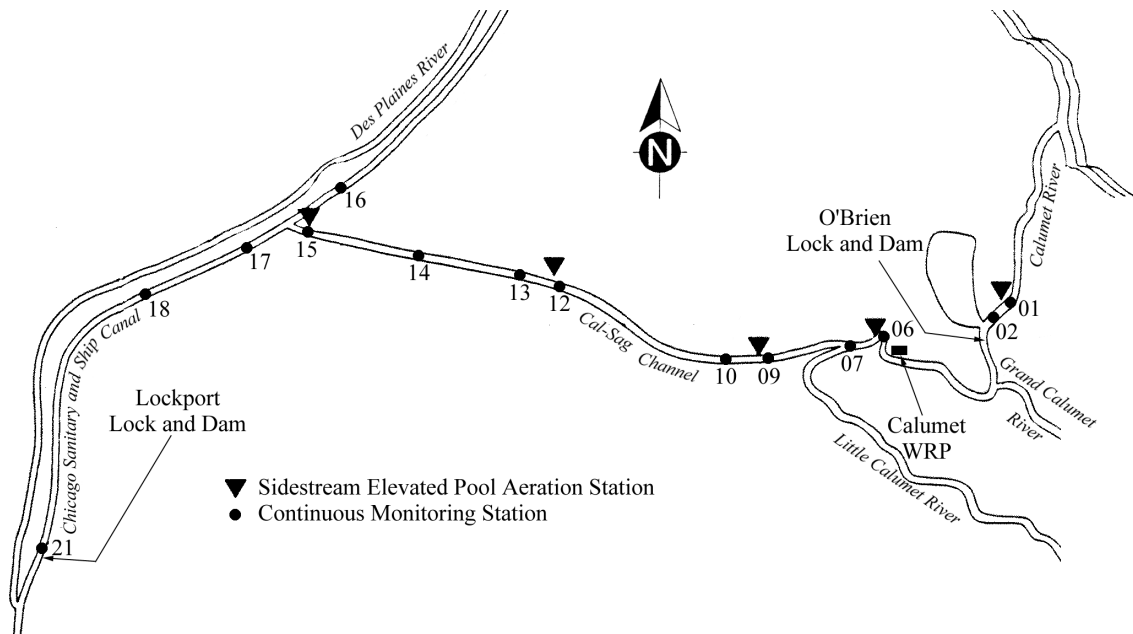

Continuous Monitoring Stations

0	SEPA Station 1 intake,	13	Southwest Hwy,
1	RM 328.10		RM 310.70
0	Norfolk/Western RR,	14	104 th Avenue,
2	RM 327.69		RM 307.15
0	SEPA Station 2 intake,	15	SEPA 5 intake,
6	RM 321.32		RM 303.63
0	Penn Central RR,	16	Hwy 83,
7	RM 320.71		RM 304.69
0	SEPA Station 3 intake,	17	Power Lines,
9	RM 318.08		RM 302.36
1	Baltimore/Ohio RR,	18	Slip No. 2,
0	RM 317.62		RM 299.55
1	SEPA Station 4 intake,	21	Lockport Lock and Dam,
2	RM 311.55		291.20

Figure 1. SEPA station and continuous monitoring locations in the Chicago, Illinois area along the Calumet River, Little Calumet River, Cal-Sag Channel, and the lower Chicago Sanitary and Ship Canal



Figure 2. SEPA Station 1 outfall



Figure 3. SEPA Station 2 outfall



Figure 4. SEPA Station 3 outfall



Figure 5. SEPA Station 4 outfall



Figure 6. SEPA Station 5 outfalls: Chicago Sanitary and Ship Canal (left) and Cal-Sag Channel (right)

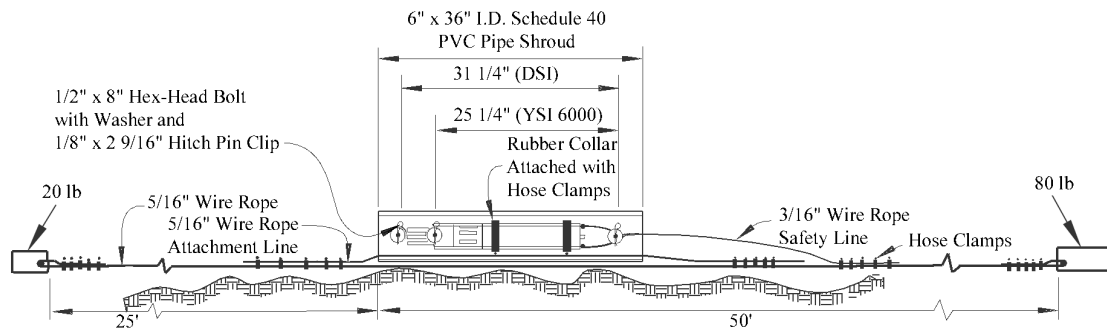

7a. Type I

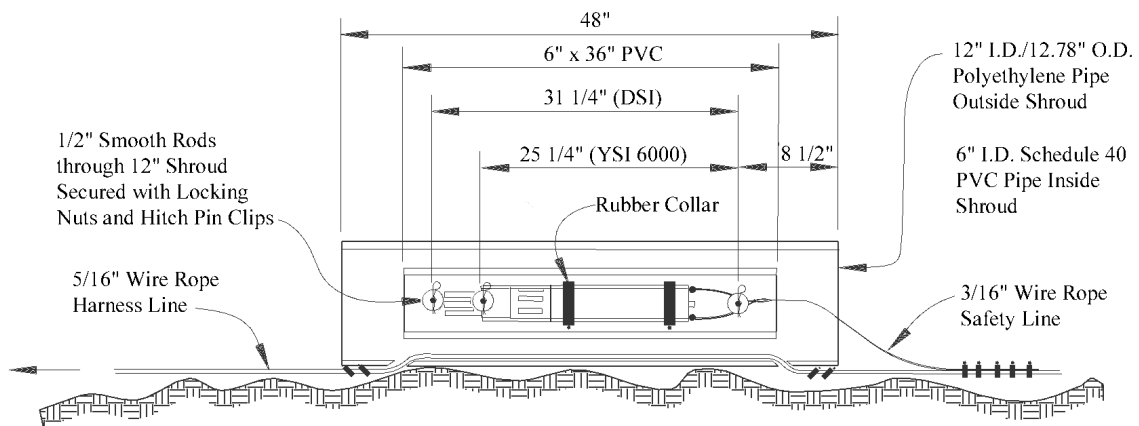

7b. Type IA

Figure 7. Schematics of type I and IA monitor riggings

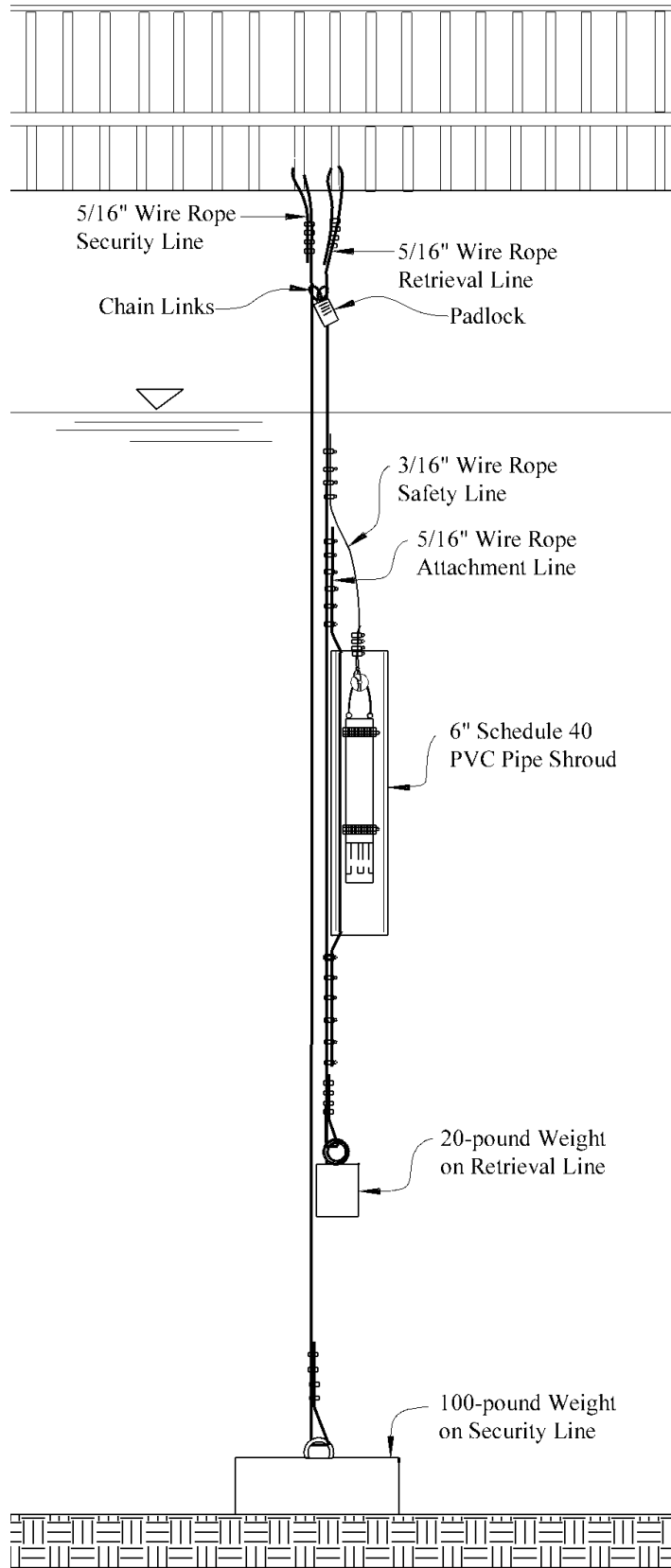

Figure 8. Schematic of type II monitor rigging

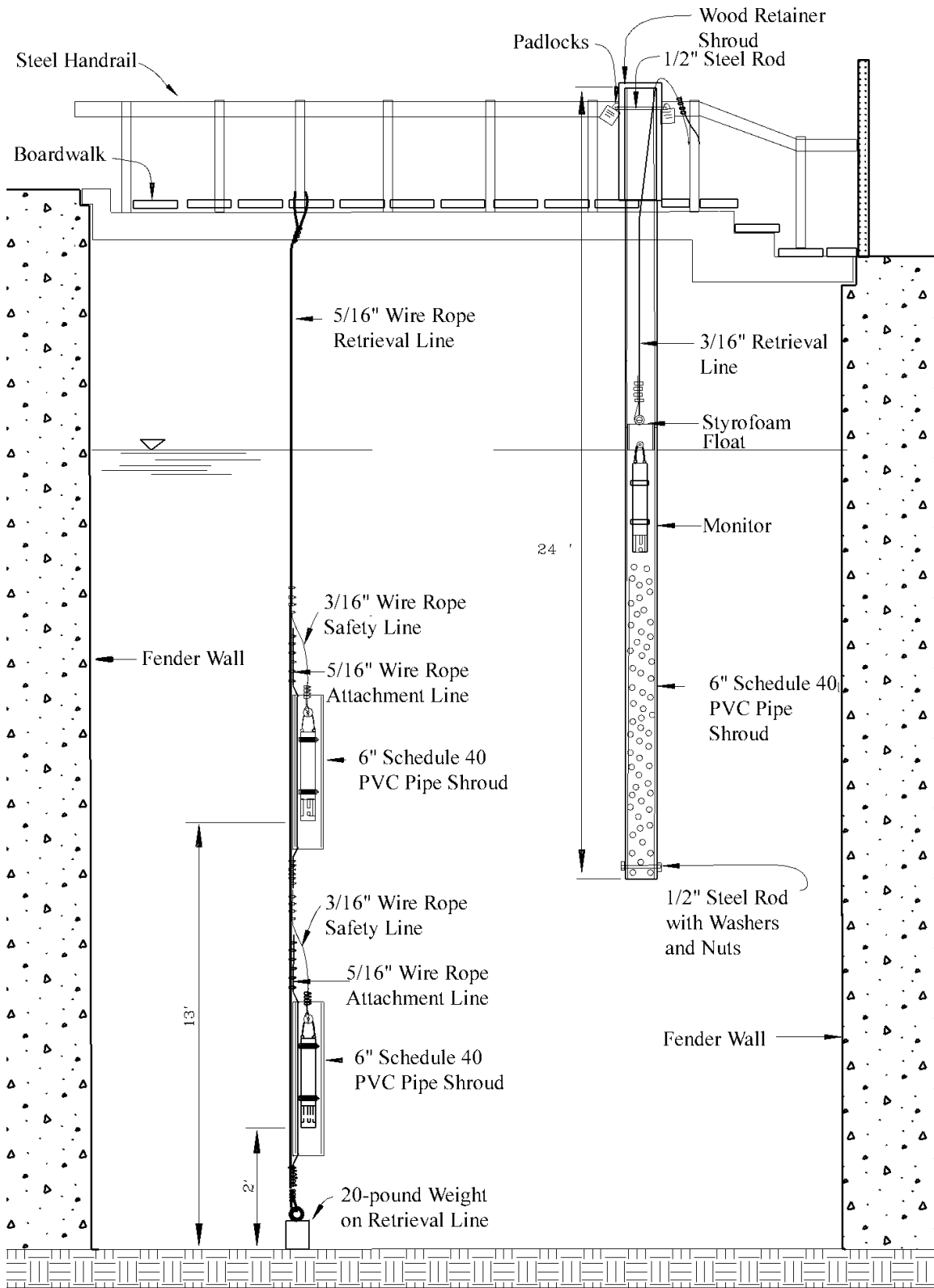

Figure 9. Schematics of type IIA (left) and IIB (right) riggings used at Lockport

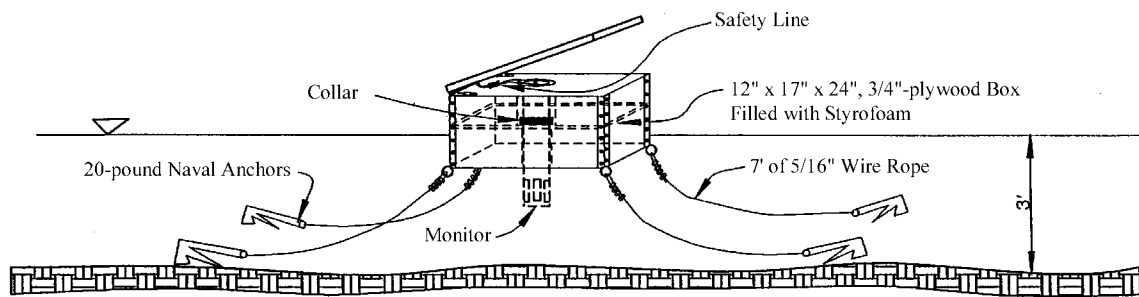

Figure 10. Schematic of type III rigging



Figure 11. Type I rigging



Figure 12. Type IA rigging



Figure 13. Type II rigging



Figure 14. Type III rigging



Figure 15. Inserting Data Sonde I into type III rigging

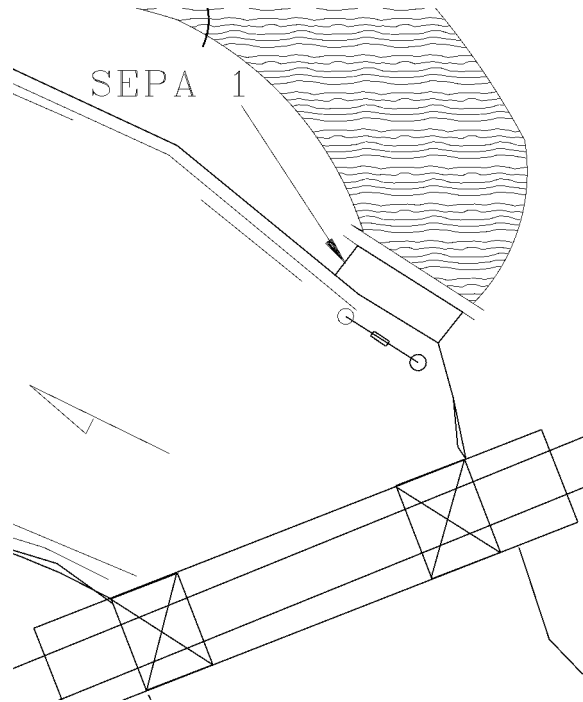

a. Station 01: SEPA Station 1 intake, Calumet River at RM 328.10

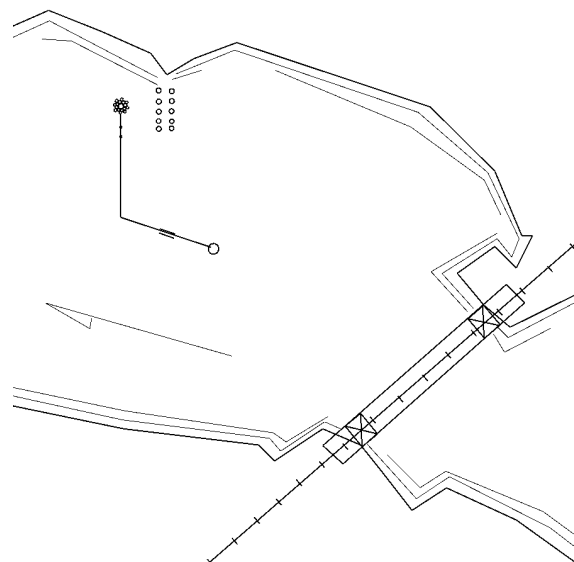

b. Station 02: Norfolk/Western RR, Calumet River at RM 327.69

Figure 16. Plan view schematics of riggings at each continuous monitoring station

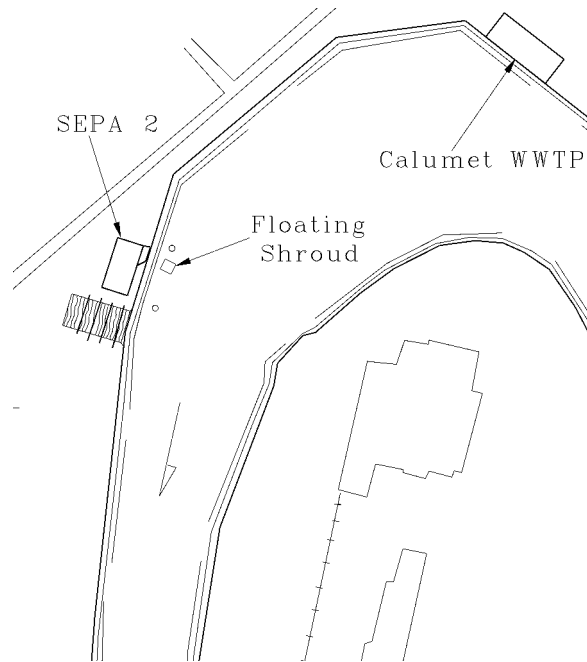

c. Station 06: SEPA Station 2 intake, Little Calumet River at RM 321.32



d. Station 07: Penn Central RR, Little Calumet River at RM 320.71

Figure 16. (continued)

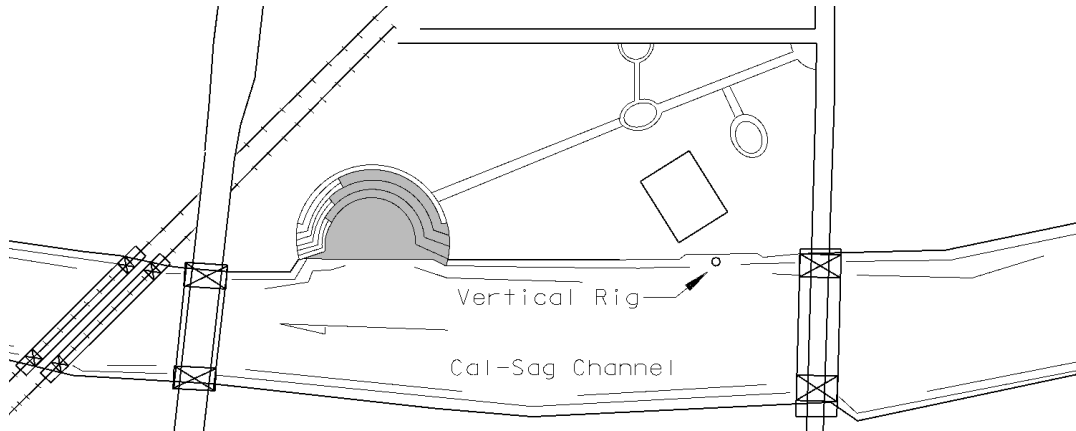

e. Station 09: SEPA Station 3 intake, Cal-Sag Channel at RM 318.08

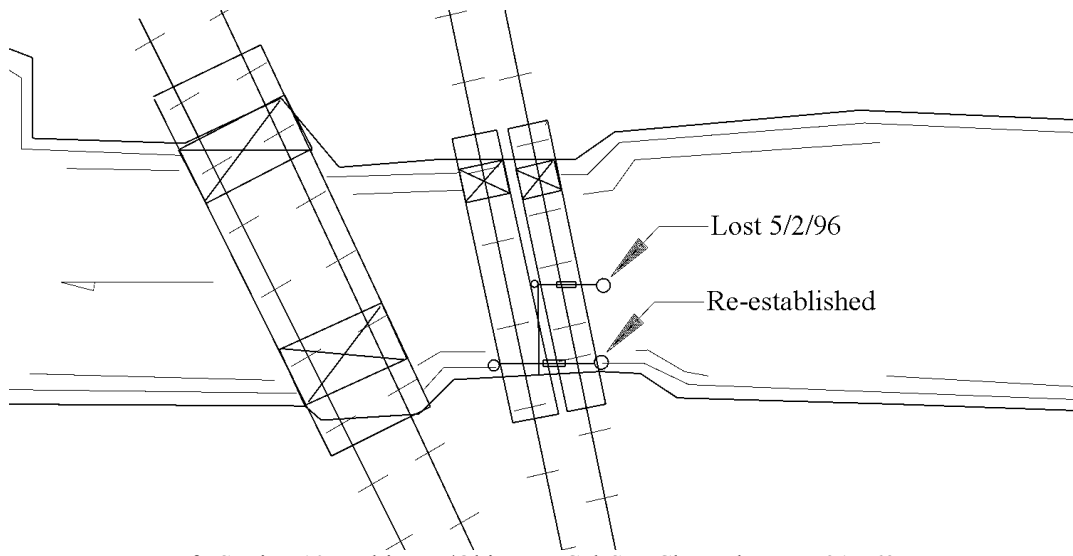

f. Station 10: Baltimore/Ohio RR, Cal-Sag Channel at RM 317.62

Figure 16. (continued)

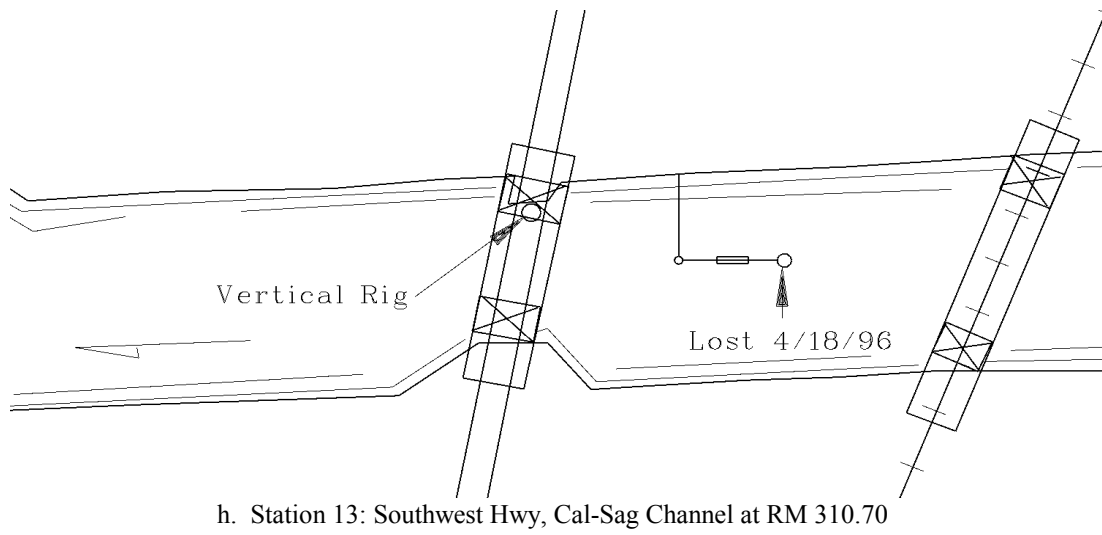
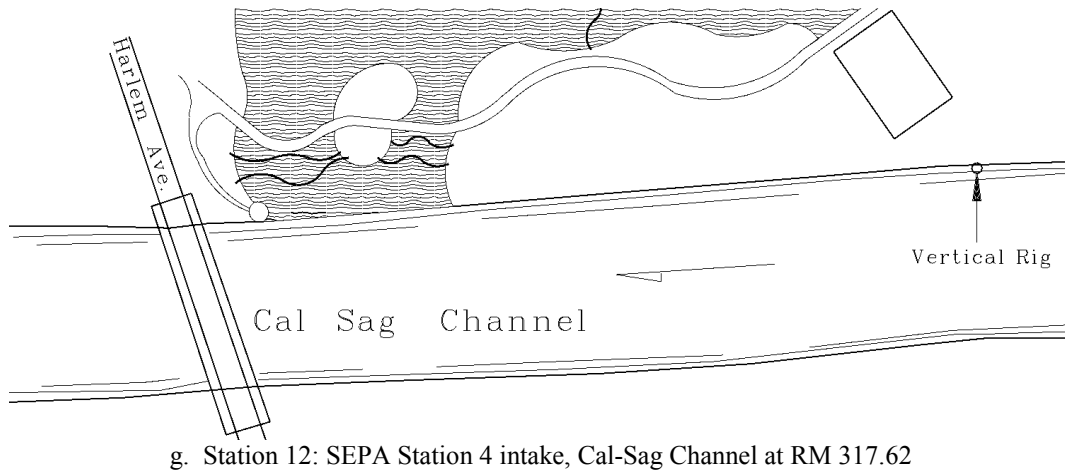
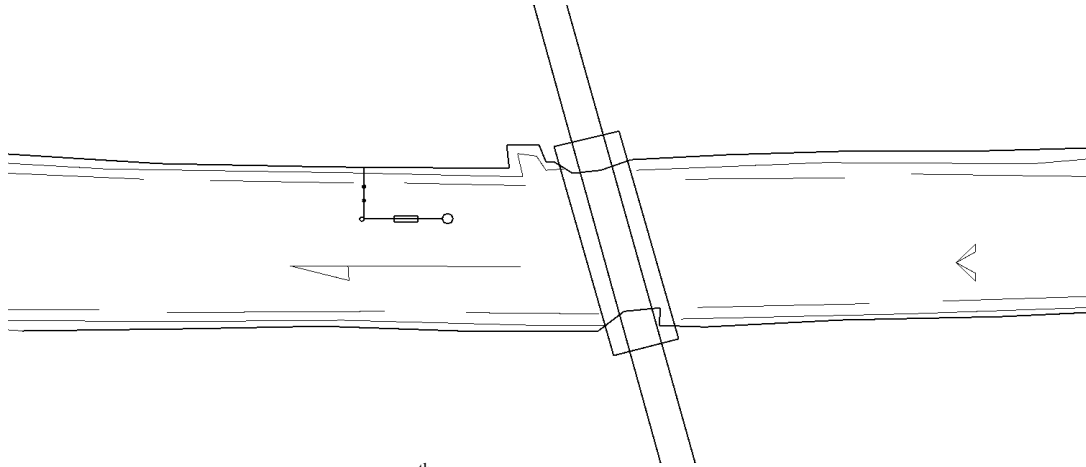
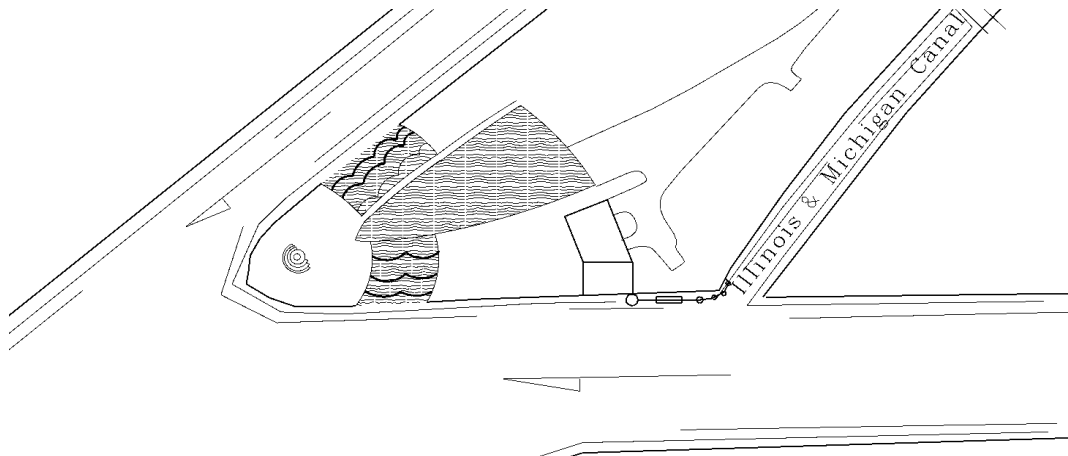

Figure 16. (continued)



i. Station 14: 104th Avenue, Cal-Sag Channel at RM 307.15



j. Station 15: SEPA Station 5 intake, Cal-Sag Channel at RM 307.15

Figure 16. (continued)



k. Station 16: Hwy83, Chicago Sanitary and Ship Canal at RM 303.63

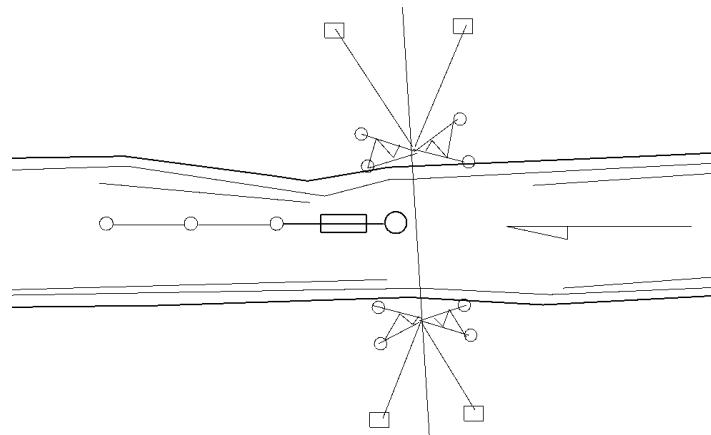

l. Station 17: Power Lines, Chicago Sanitary and Ship Canal at RM 302.36

Figure 16. (continued)

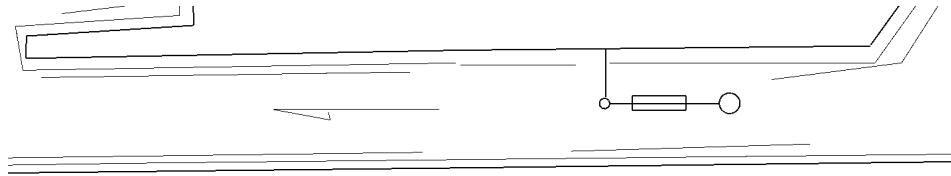

m. Station 18: Slip No. 2, Chicago Sanitary and Ship Canal at RM 299.55

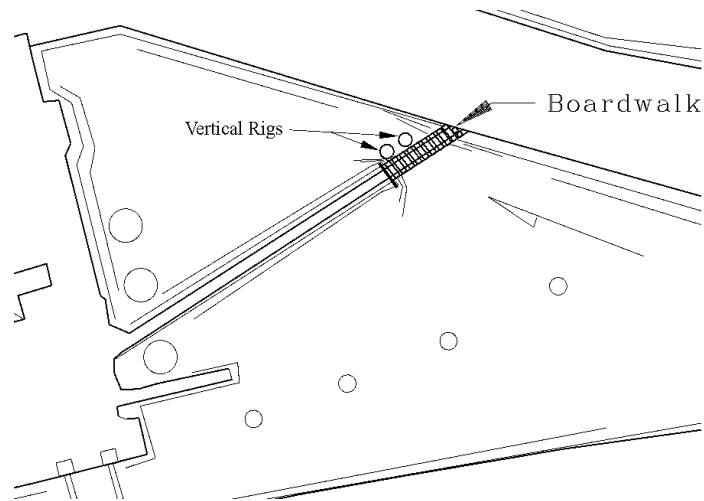

n. Station 21 (t, m, b): Lockport Lock and Dam,
Chicago Sanitary and Ship Canal at RM 291.20

Figure 16. (concluded)

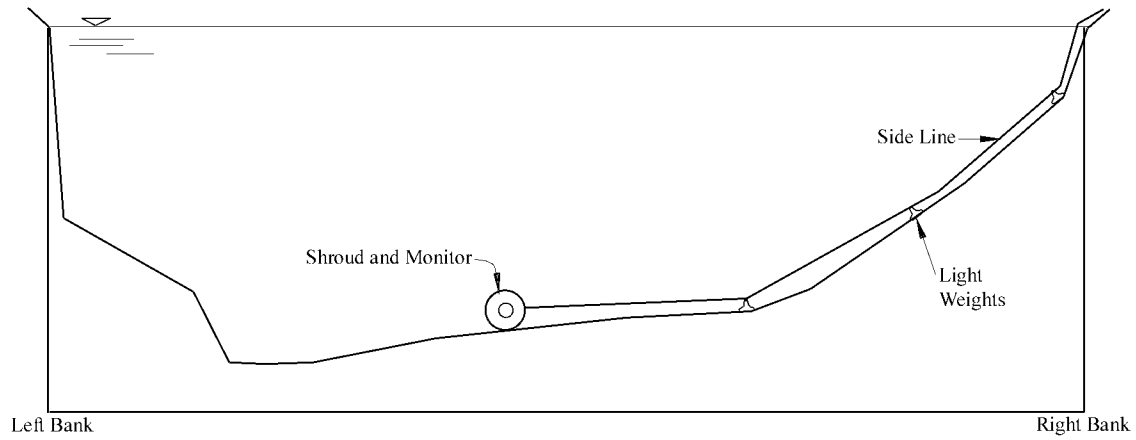

a. Transverse view looking downstream

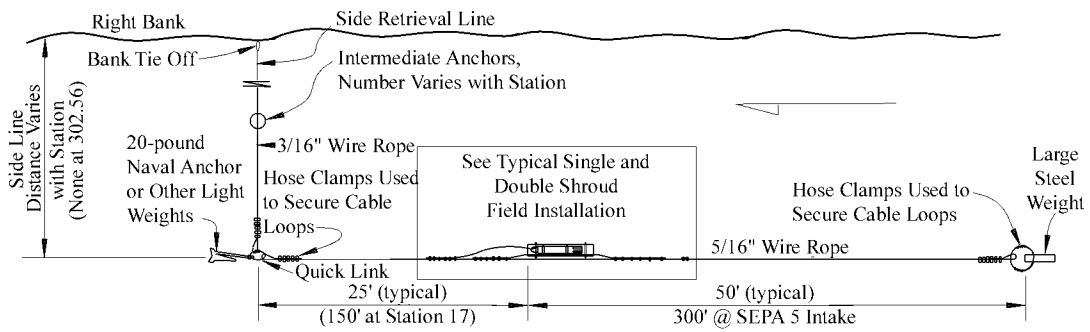

b. Longitudinal view

Figure 17. Typical type I and IA side-line retrieval setups



Figure 18. Boat with monitors in protective shrouds



Figure 19. Retrieval of type IA rigging



Figure 20. Exchanging a DataSonde I monitor at a type IA site



Figure 21. Exchanging a YSI 6000 monitor at a type IA site



Figure 22. Downrigger fitted with YSI DO/temperature meter, stirrer, and probes

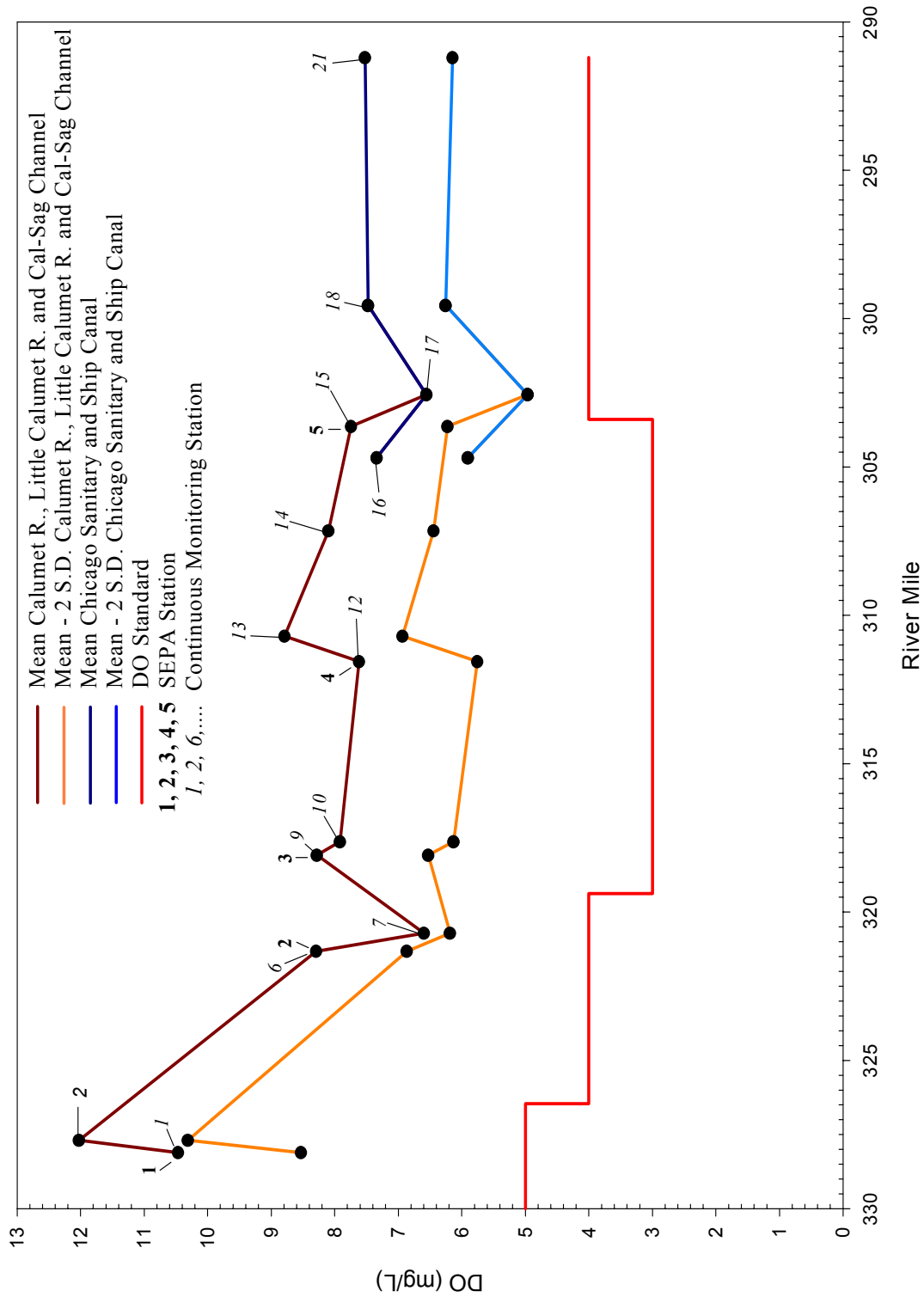

Figure 23. Period 1 (03/16-04/18/1996) DO profile: no discretionary diversion, no SEPA operation

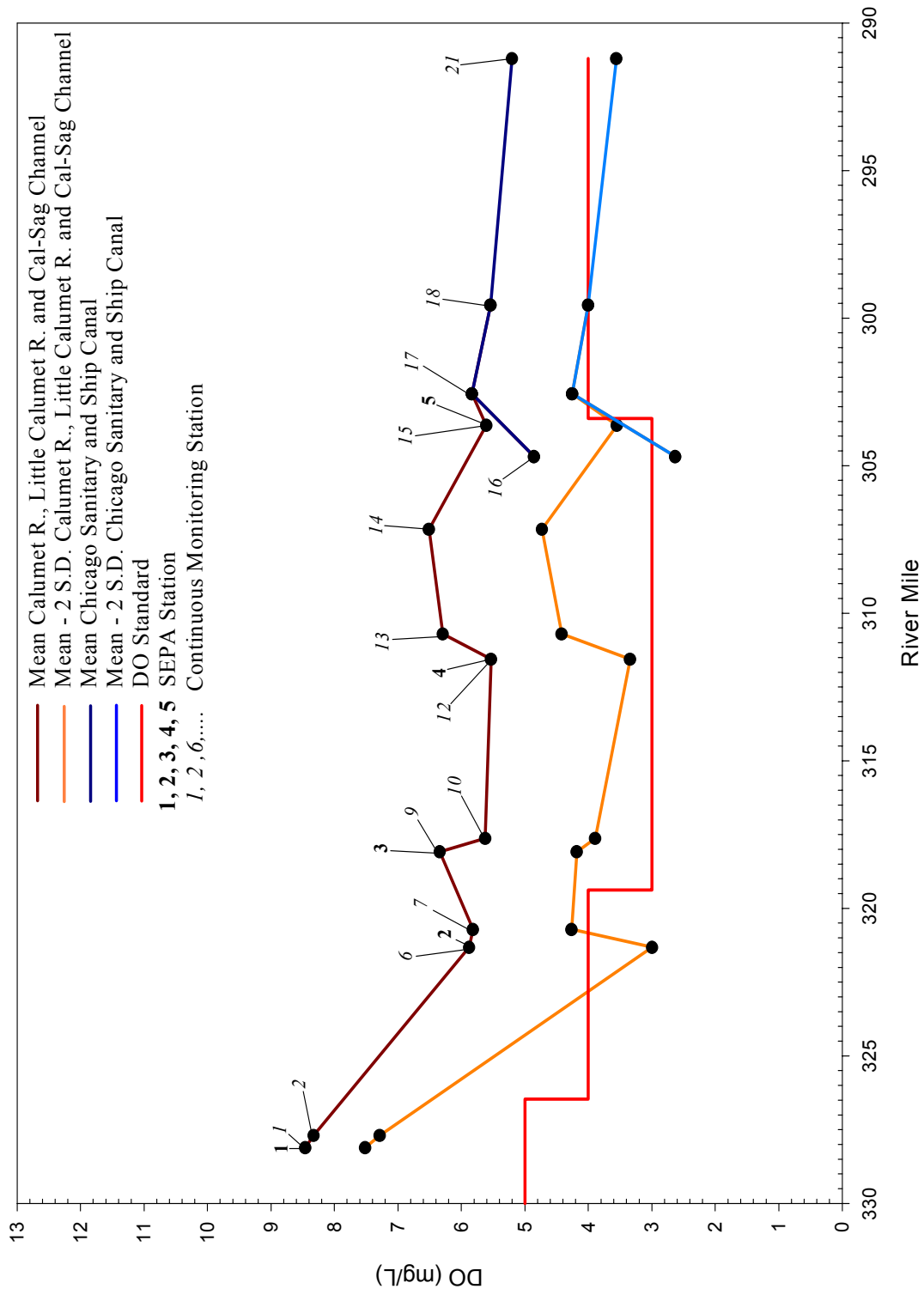

Figure 24. Period 2 (04/19–05/30/1996) DO profile: discretionary diversion (cfs): min = 0, mean = 199, max = 541, with SEPA operation

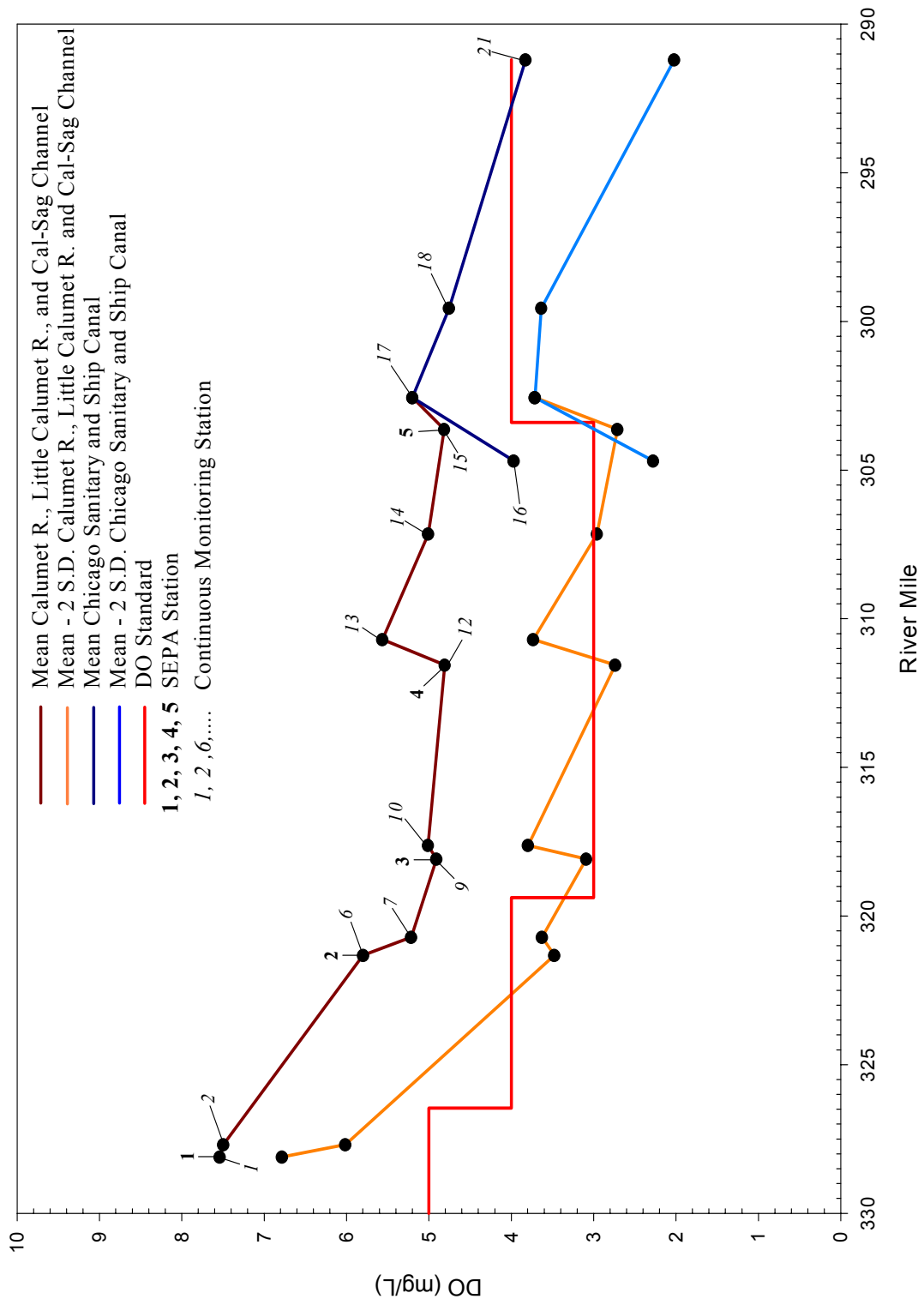

Figure 25. Period 3 (05/31–07/03/1996) DO profile: discretionary diversion (cfs): min = 0, mean = 162, max = 235, with SEPA operation

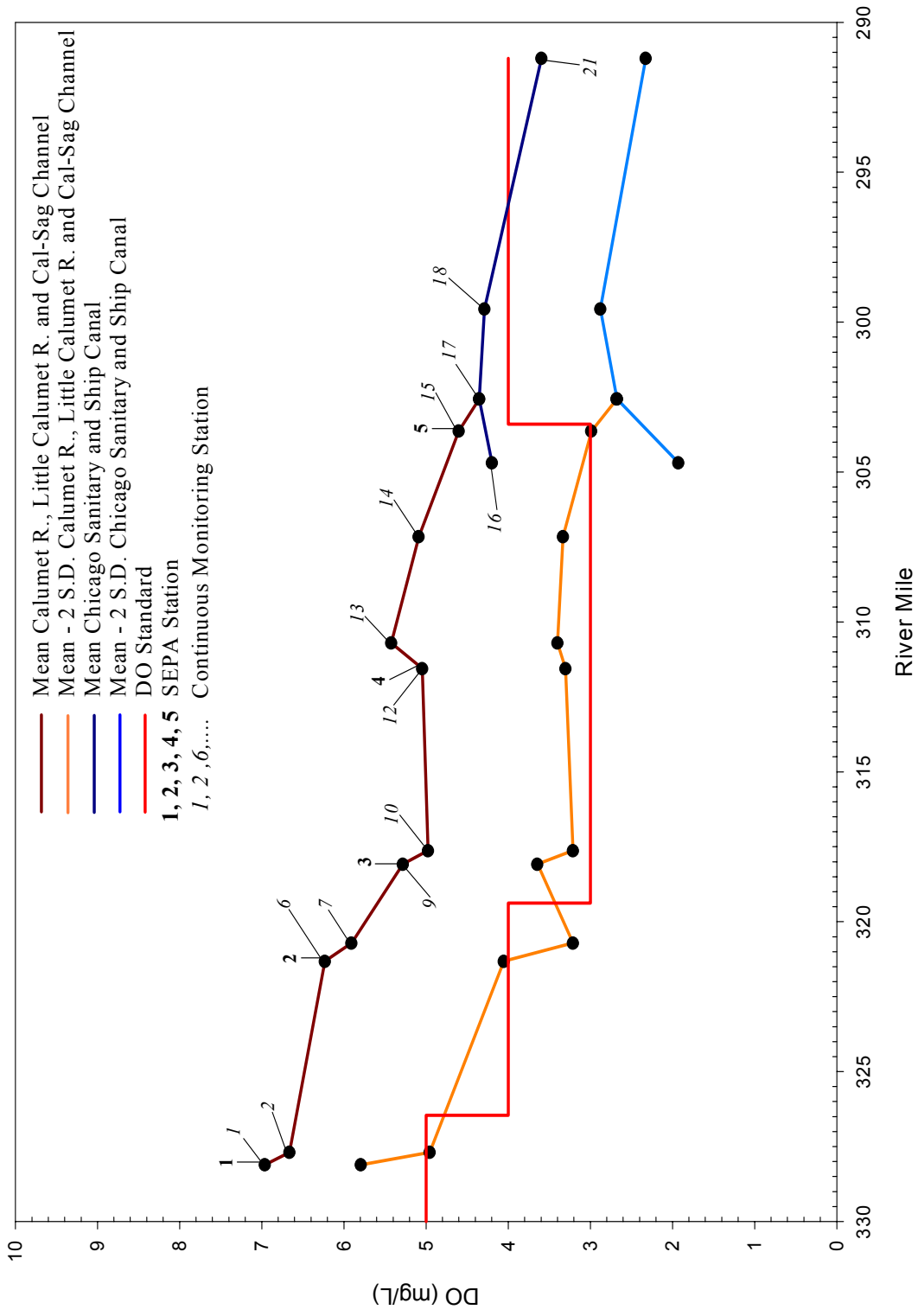

Figure 26. Period 4 (07/04–09/25/1996) DO profile: discretionary diversion (cfs): min = 0, mean = 380, max = 532, with SEPA operation

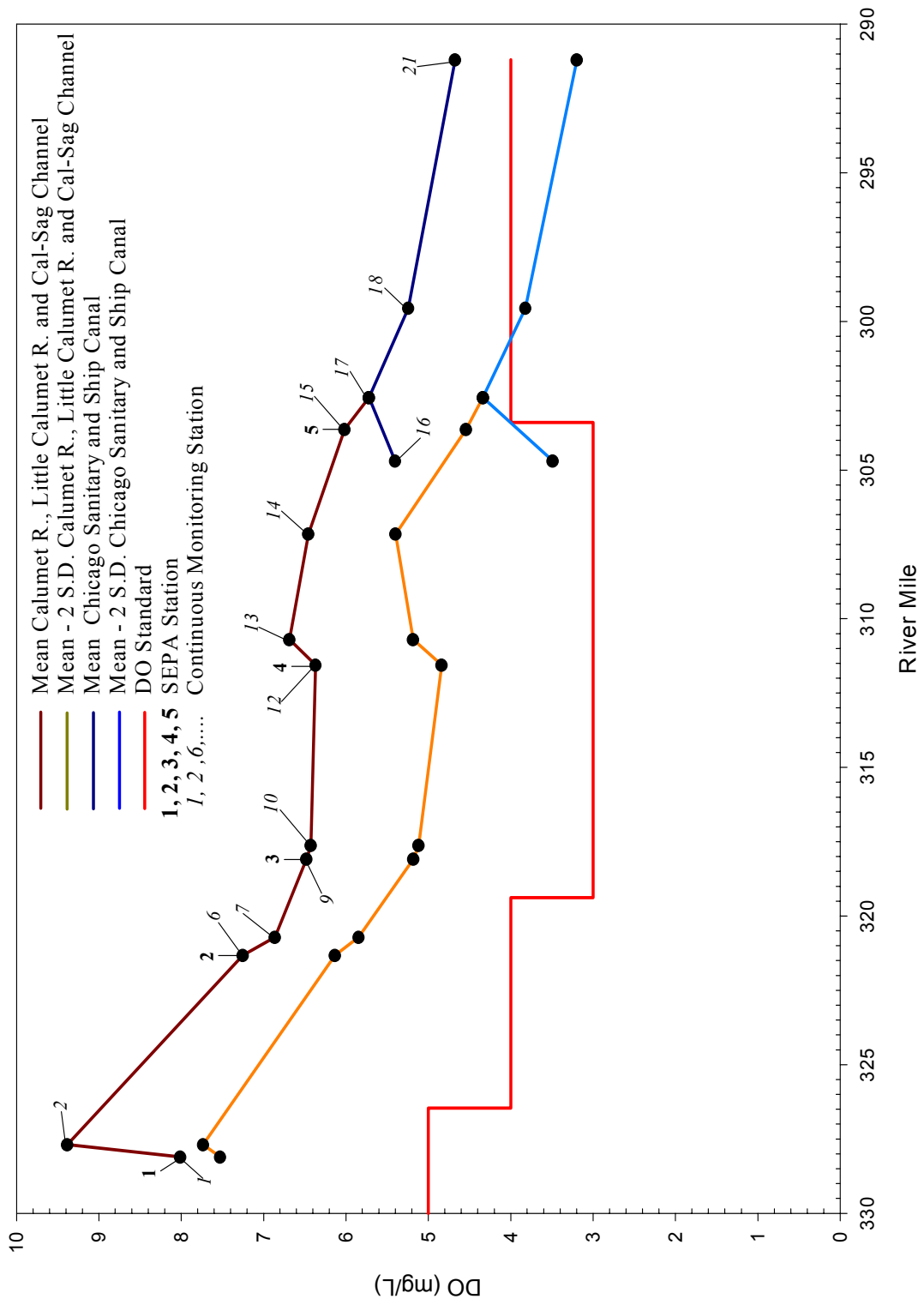

Figure 27. Period 5 (09/26–10/31/1996) DO profile: discretionary diversion (cfs): min = 99, mean = 336, max = 541, with SEPA operation

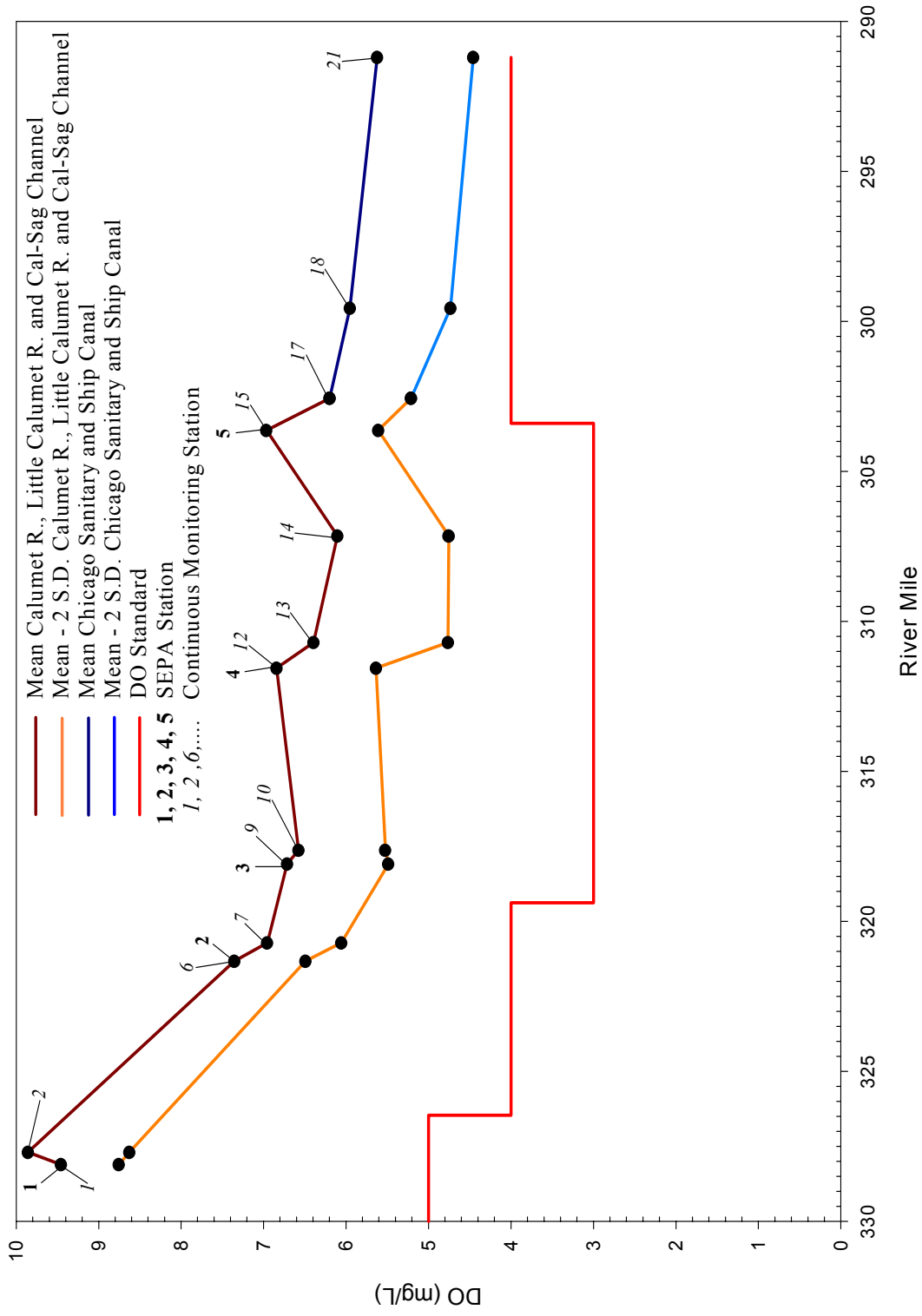

Figure 28. Period 6 (11/01-11/19/1996) DO profile: no discretionary diversion, no SEPA operation

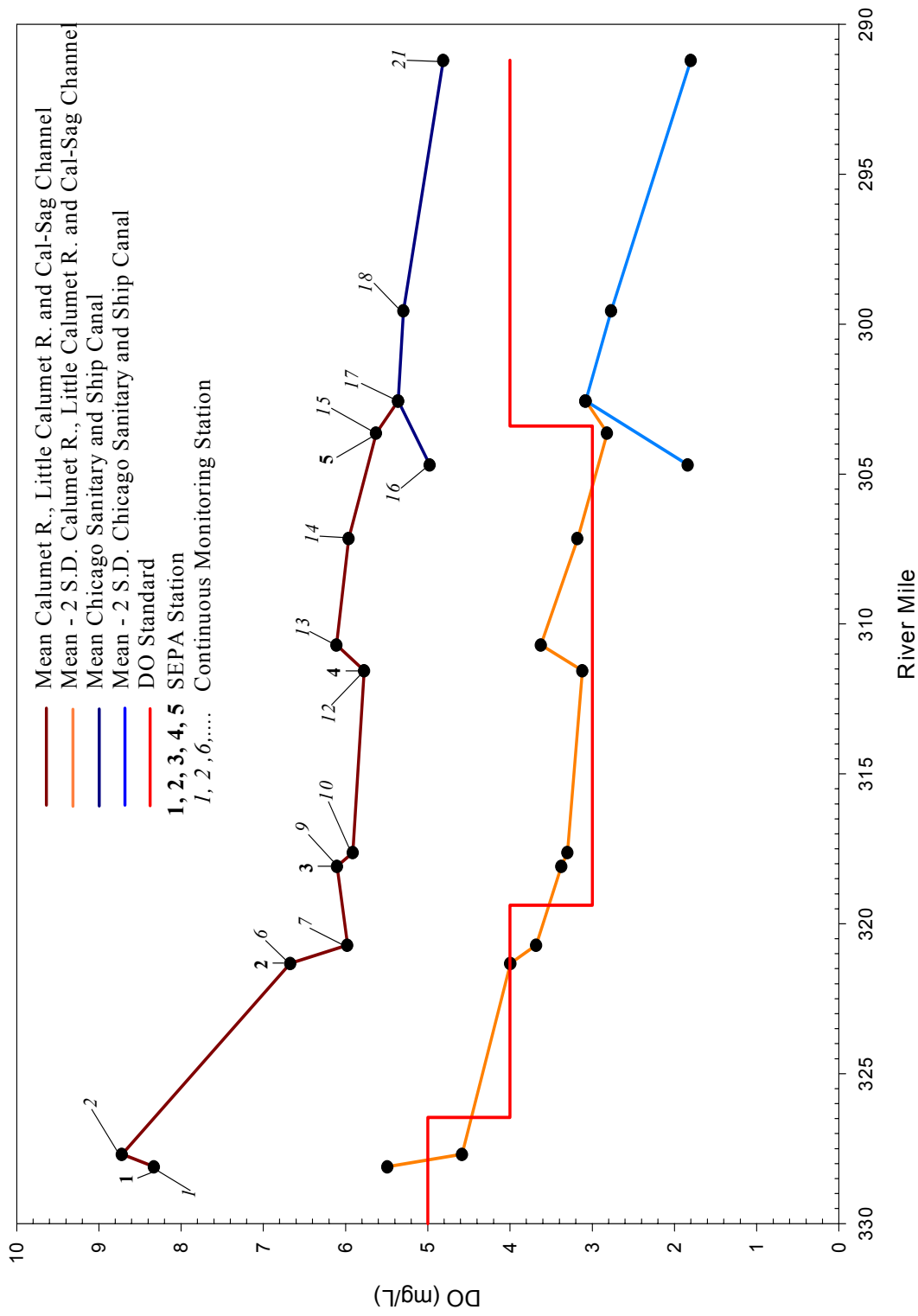

Figure 29. Periods 1-6 (03/16-11/19/1996) DO profile: including a full range of discretionary diversions with and without SEPA operation

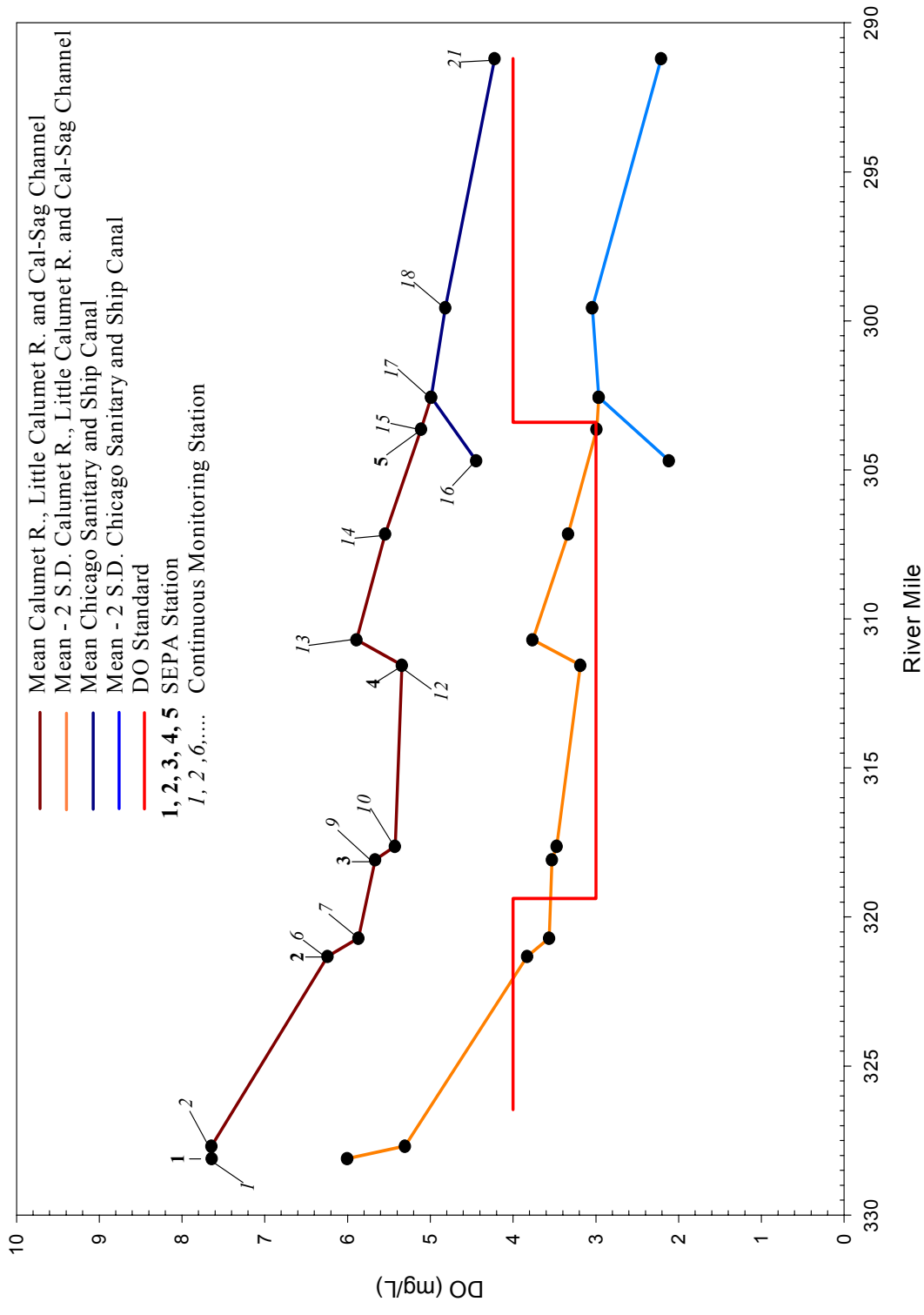

Figure 30. DO profile for 04/19–10/31/1996, the period during which the SEPA stations operated

Appendix A
YSI Model 6000_{UPG}

Appendix A.
YSI Model 6000_{UPG}: Water
Quality Monitor/Datalogger Specifications

General Specifications

- Medium: Fresh, sea, or polluted water
- Temperature: -5 to +45°C
- Computer interface: RS232, SDI-12
- Software: Works with a PC compatible with 3.5-inch or 5.25-inch high- or low-density floppy disks; 256K RAM minimum. Graphic card recommended.
- Depth: 0 to 500 feet
- Size 3.5-inch dia., 19.5-inch long, 6.5 pounds
- Internal logging memory: 256 kilobytes, 150,000 individual readings
- Power: 12VDC, 8 alkaline C cells; external 12VDC
- Battery life: 120 days; 90 days with DO; 45 days with DO and turbidity, at 15-minute logging intervals at 25°C

Typical Performance Specifications

<i>Parameter</i>	<i>Unit</i>	<i>Specification</i>		
		<i>Range</i>	<i>Resolution</i>	<i>Accuracy</i>
Dissolved oxygen	% Saturation	0 to 200	0.1	± 2%
Dissolved oxygen	mg/L	0 to 20	0.01	± 0.2 mg/L
Conductivity	mS/cm	0 to 100	0.01	± 0.5% + 0.001 mS/cm
Temperature	°C	-5 to 45	0.01	± 0.15°C
pH	pH units	2 to 14	0.01	± 0.2
Salinity	ppt	0 to 70	0.01	greater of: ± 1%; 0.1 ppt
Turbidity	NTU	0 to 1000	0.1	greater of: ± 5%; 2 NTU

Notes: mS/cm = millisiemens/centimeter

ppt = parts per thousand

NTU = nephelometric turbidity units

Appendix A. (continued)
YSI 6000_{UPG}: Water Quality Monitor/Datalogger:
Standard Operating Procedures

Presented are standard operating procedures (SOP) including quality assurance/quality control (QA/QC) procedures developed during this study for water quality monitor use. Although specifically referenced to the YSI 6000_{UPG} units, most of the information presented here is applicable to the DataSonde 1 and 3s and the YSI model 6920.

EQUIPMENT AND SUPPLY REQUIREMENTS

- IBM compatible PC
- DO Winkler kit
- Laboratory pH meter
- pH standard solutions
- Laboratory conductivity meter
- Conductivity standard solutions
- Temperature regulated water bath
- NIST-grade mercury thermometer
- Large water tank suitable for holding and submersing the maximum number of units expected to be used at one time.
- Voltmeter
- Razor knife
- 50x magnifying glass
- Log book, checklist, record sheets
- 5-gallon buckets
- Alcohol
- Cotton swabs
- Standard 1 mil DO membranes
- Saturated KCl solution
- Size-C alkaline batteries (YSI 6000), size-D (DataSonde 1); size - AA (YSI 6920 and DS 3)
- Lightweight plastic wash tub
- Large scrub brush
- Small, soft-bristled scrub brush

PREPARATION FOR CALIBRATION

Approximately 45 minutes are required to prepare for the calibration of each instrument. These procedures are to be performed at least 24 hours prior to actual calibration. A standard maintenance checklist is used to ensure quality and consistency over the course of a study.

Appendix A. (continued)

The maintenance procedures include:

- Washing instrument exteriors using mild detergent or soapy water solution if necessary with large scrub brush
- Removing and cleaning probe guards
- Cleaning all probe exteriors with deionized (DI) water and/or alcohol if necessary
- Cleaning cable connection contacts
- Cleaning and lubricating all O-rings
- Cleaning conductivity electrodes with small, soft-bristled scrub brush
- Removing batteries from instrument compartment and cleaning compartment with compressed air
- Checking collectively, all eight batteries for minimum acceptable voltage
- Replacing all eight batteries if collective voltage is less than 10.5 V
- Testing voltage of all replacement batteries to ensure each has a minimum voltage of 1.5 V
- Replacing KCl electrolyte and DO membranes
- Examining replaced membranes using a magnifying glass for tears, creases, holes, and air bubbles
- Installing clean probe guards with bottom open (i.e., bottom guard removed)
- Filling 5-gallon buckets with tap water for rinsing probes between calibration steps
- Draining and refilling holding tank with fresh tap water
- Immersing all instruments to be used vertically in holding tank.

CALIBRATION PROCEDURES

Prior to actual instrument calibration, calibration reagents are prepared; this requires 15 to 30 minutes of effort. Approximately 75 minutes are required to calibrate each instrument. A standard calibration checklist and recording sheet is used to ensure quality and consistency over the course of the study.

Starting with the instrument submersed in a water-filled holding tank, the calibration procedure consists of:

- Removing units, as needed, from the holding tank and calibrating each probe (parameter) according to the procedures outlined in sections 3.1 (calibration tips) and 3.2 (calibration procedures) of the YSI 6000_{UPG} *Multi-Parameter Water Quality Monitor Instruction Manual*, Endeco/YSI Incorporated, Environmental Monitoring Systems, 13 Atlantis Drive, Marion MA 02738, pp 3-1 through 3-8.
- Calibrating all monitors using a common batch of calibration reagents. However, difficult calibrations for a given parameter may be encountered. Try overcoming such occurrences by preparing and using a new set of reagents for that parameter.

Appendix A. (continued)

- Running the monitor diagnostic function (following calibration) using YSI's PC 6000 software and recording the cell constant, DO gain, and DO charge. Acceptable ranges for these parameters are:

cell constant	5.0 ± 0.4
DO gain	0.5 to 2.0
DO charge	25.0 to 75.0

This information is used to assess the quality of the calibration and whether the probes are functioning properly.

- Returning the monitor to the holding tank with it set to record parametric readings at five-minute intervals over a 15-minute period. Commensurate independent readings of DO, pH, temperature, conductivity, and, in some instances, turbidity are taken to determine if the instrument readings meet specifications. Also, these readings are to be used later in QA/QC computations to correct for instrument drift and probe fouling in the field. The independent readings are determined as follows:

DO	Winkler wet chemistry technique
pH	Orion lab pH meter
temperature	NIST grade mercury thermometer
conductivity	Labcraft lab conductivity meter
turbidity	Monitek nephelometer

The instrument parametric readings are viewed on the PC monitor screen as the independent readings are recorded.

- Setting the field data logging interval using the RUN menu in the YSI PC6000 software program when all calibration specifications are met.
- Setting up a computer file for each instrument using no more than eight characters for identification.
- Labeling or identifying each unit using tape and an ink marker as to file location and/or in-stream use location.
- Leaving units submersed in holding tank until delivery from lab.

DELIVERY FROM LAB

Approximately 60 minutes need to be allotted in the lab to prepare for transporting the instruments to the field. The units are fitted with two 3/8-inch soft-rubber collar-bushings secured with stainless-steel hose clamps, which act as protective shock absorbers during transportation and during in-stream delivery. The units are transported inside 6-inch, 30-inch long schedule 40 PVC tubes. Units are hung in the tubes from 1/2-inch hex-head bolts secured on the threaded sides with hitch pin clips and flat washers. The monitor probes should never be exposed to freezing conditions, and the units, as a whole, should never be directly exposed to the sun or other heated

Appendix A. (continued)

conditions when out of the water. During outdoor exposure to freezing conditions, the transport cups (a.k.a. DO calibration cups) should be filled with a saturated brine solution of common salt.

To help maintain a moist environment, the calibration/transport cups are supplied with a small, thin piece of kitchen-type sponge that lays loose in the cup bottom. This arrangement is deficient in several aspects: because it is loose, it easily becomes lost or misplaced; because it is small, it dries out quickly; and because of the poor quality of material, it quickly deteriorates with use.

The factory-supplied loose-sponge method has been abandoned and replaced with a more voluminous and stable sponge insert. Circular pieces of ¼-inch thick rubber sponge have been cut to snugly fit into the bottom of the cup where it is glued with rubber cement. On top of the sponge, ¼-inch thick Plexiglas rings with 2½-inch diameter center holes are glued. The primary purpose of the rings is to provide free space between the sponge and the probe surfaces. This free space is needed as the bottom plate of the probe guards are not used. These protective plates restrict water movement past the probes and provide a media for undesirable biological film development in nutrient-rich water. The probe most vulnerable to in-stream damage, the DO probe, is protected by a ¼-inch wood-dowel rod spanning the diameter of the guard. An aluminum protective dowel was tried initially, but a transfer of electrons between the electrolyte in the probe cells and the metal set up galvanic activity, and deposits quickly build up along the metal rod.

Work tasks associated with the transfer of the monitors to the field include:

- Measuring DO, pH, conductivity, and temperature in the holding tank immediately before removal of the units. These measurements are for use later in performing QA/QC computations.
- Checking to ensure that computer file identifications match the marked label on the monitor.
- Adding DI water to the transport cups until sponges are thoroughly saturated.
- Removing units from the tank and inserting cups over the probe guards and past the O-ring seals. The single mini set screws provided with each cup have all been removed and are not used during transport. The screws tend to get lost during delivery, and the O-ring seal is more than sufficient to hold the cups in place.
- Inserting the monitors into the PVC transport tubes and carefully handling the tubes during movement from the lab to the transport vehicle.
- Maintaining a transport cup seal for a time period sufficient for the monitor to log at least four readings before in-stream placement. Such measurements are useful in helping to trouble shoot “quirky or unusual” instrument malfunctions.

Appendix A. (concluded)

IN-STREAM PLACEMENT/RETRIEVAL

Tasks associated with field installing and removing of the monitors include:

- Removing the monitors from the transport shrouds when appropriate, and removing the transport (calibration) cups from the units when appropriate. At some installations, both the monitor and transport shroud are exchanged; for these situations, great care should be taken to remember to remove the transport cups.
- Taking water quality measurements for DO concentration, DO percent of saturation, temperature, pH, and conductivity at the in-stream monitor location before disturbing and/or removing in-place units. If an in-place unit is within ten minutes of a recording sequence, do not retrieve unit until the forthcoming measurement/recording has transpired. For insurance, allow a factor of safety of two to three minutes. These readings are for use later in performing QA/QC computations.
- Retrieving the in-place units, removing them from their protective shrouds, and inserting the replacement units into the shroud (or replacing the combined shroud/unit assembly when necessary). Inspect all pins, clips, and lines for wear and damage. Remove trash and biological growth from installation. Be sure safety line is attached directly to monitor wire handle.
- Returning units to the water being sure that the harness systems are free of entanglement and are stretched tight.
- Taking water quality measurements reasonably close to the nearest scheduled unit recording time and recording time and date.
- Cleaning retrieved units with a scrub brush with water placed in the tub when in a boat or with water from a 5-gallon bucket when on shore. Care should be taken not to clean or disturb probes. Notes should be taken on general cleanliness of probes, including membrane integrity, periphytonic grown, and sediment deposition or accumulation.
- Placing the transport cup over the guard after making sure the cup sponge is moist. Loose water should be removed from the cup to prevent accidental “cleaning” of the probes during handling and transport.
- Placing monitors in protective shrouds and transporting them back to the lab. Extremes in temperature should be avoided when staying over night in the field. During the summer, vehicles should be parked in the shade and left ventilated. During extreme freezing conditions, care should be taken to prevent the probes from freezing.

Notes: NIST = National Institute of Standards and Technology

DI = deionized water

PVC = polyvinyl chloride

Appendix B
Continuous, Hourly DO Measurements

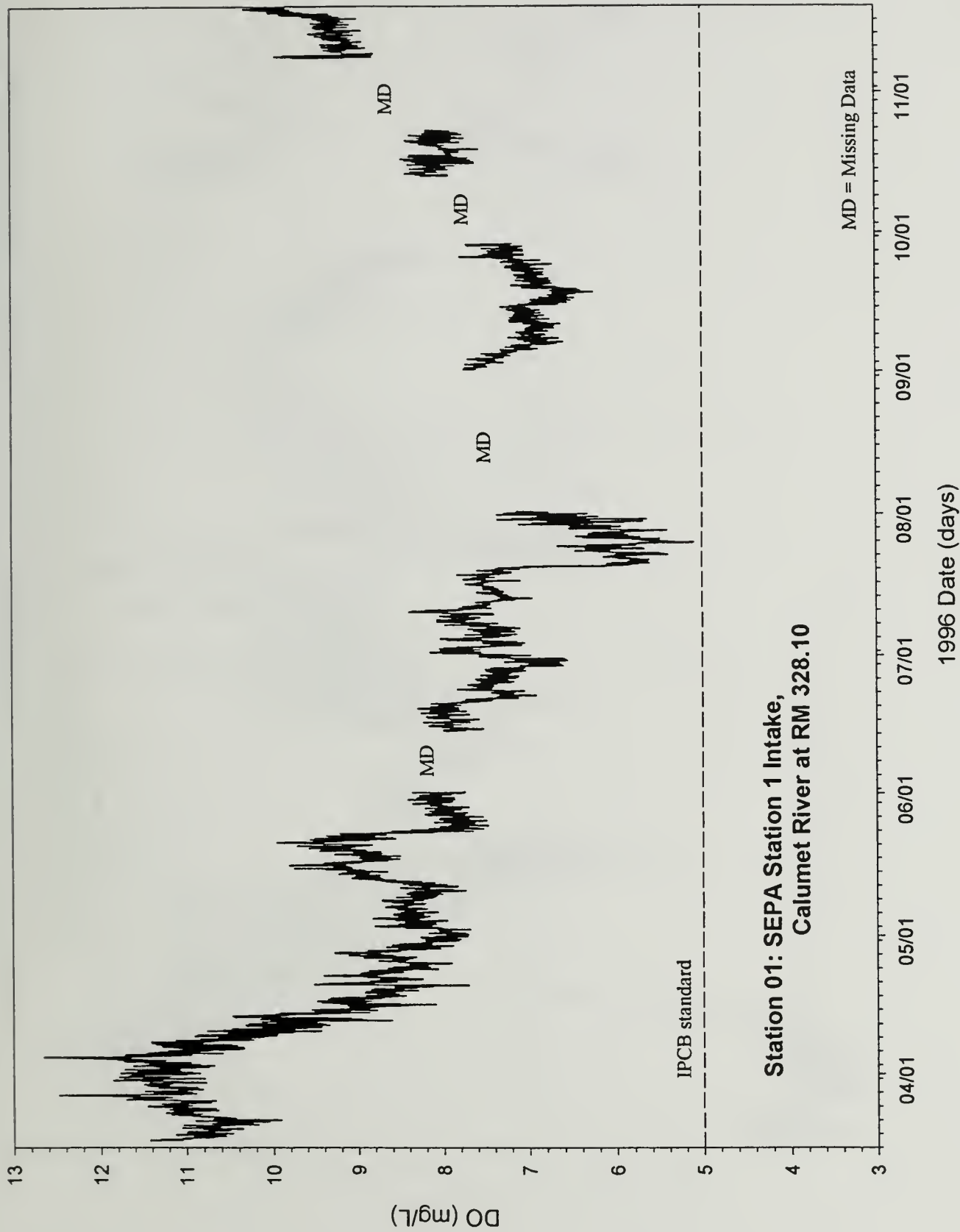

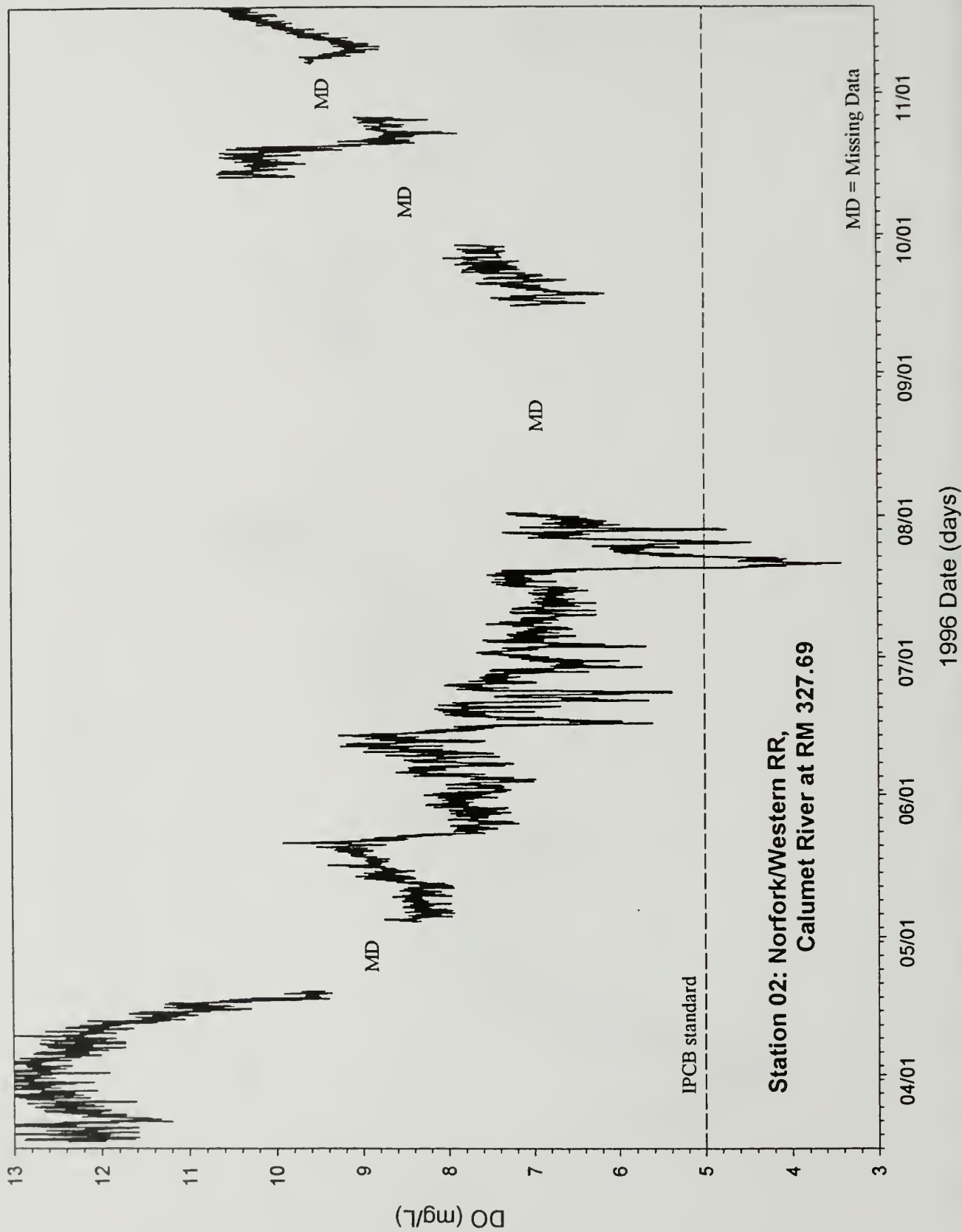

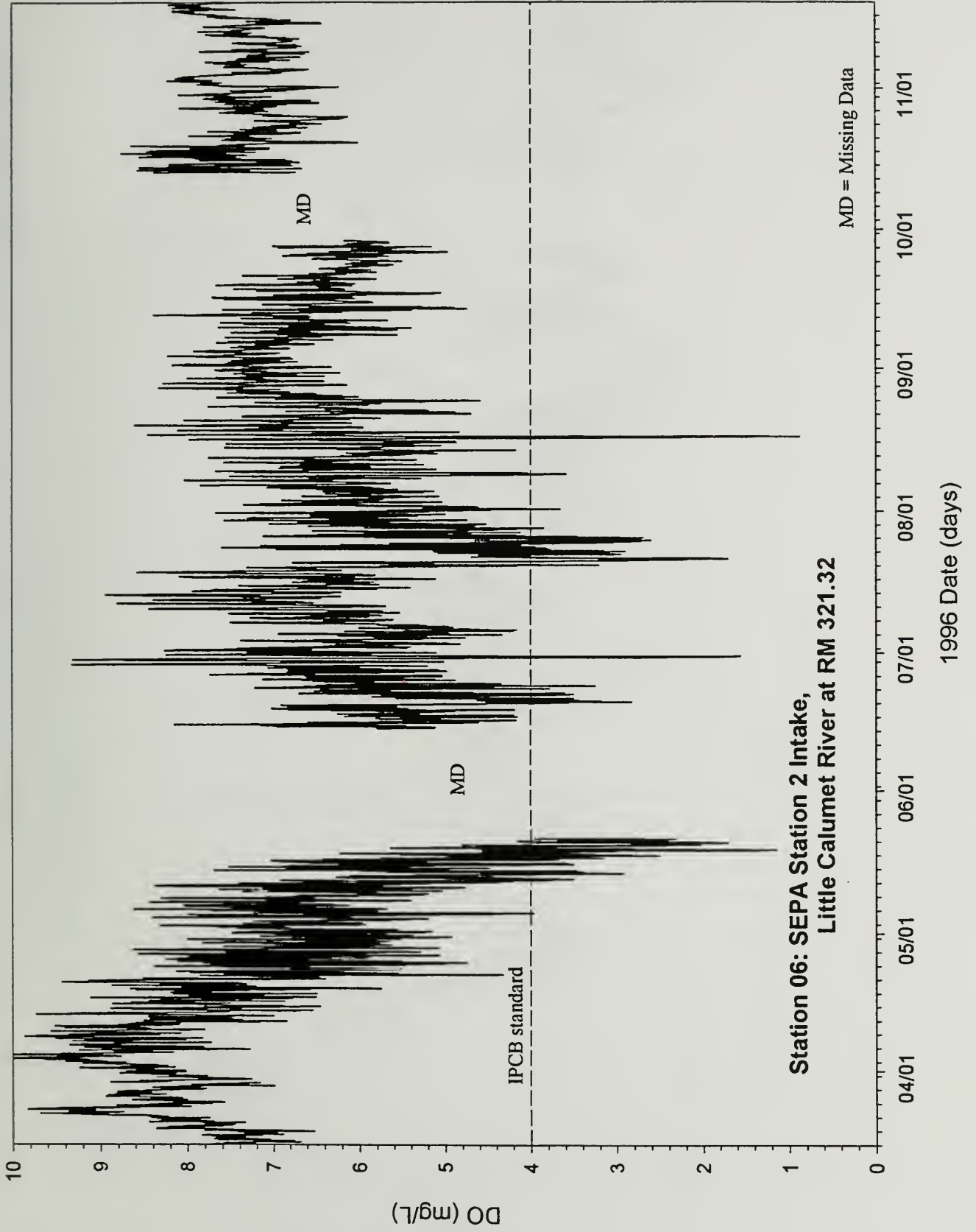

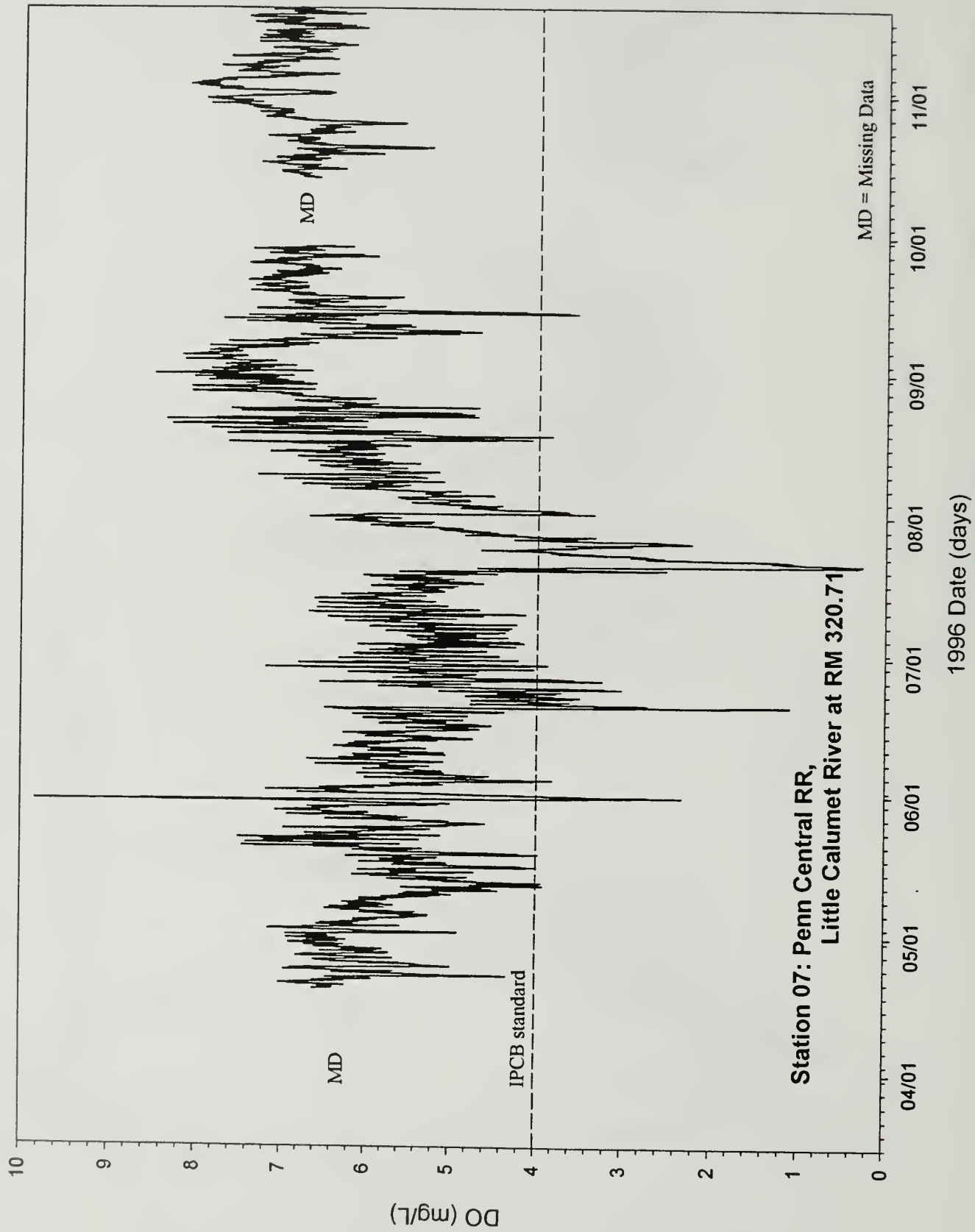

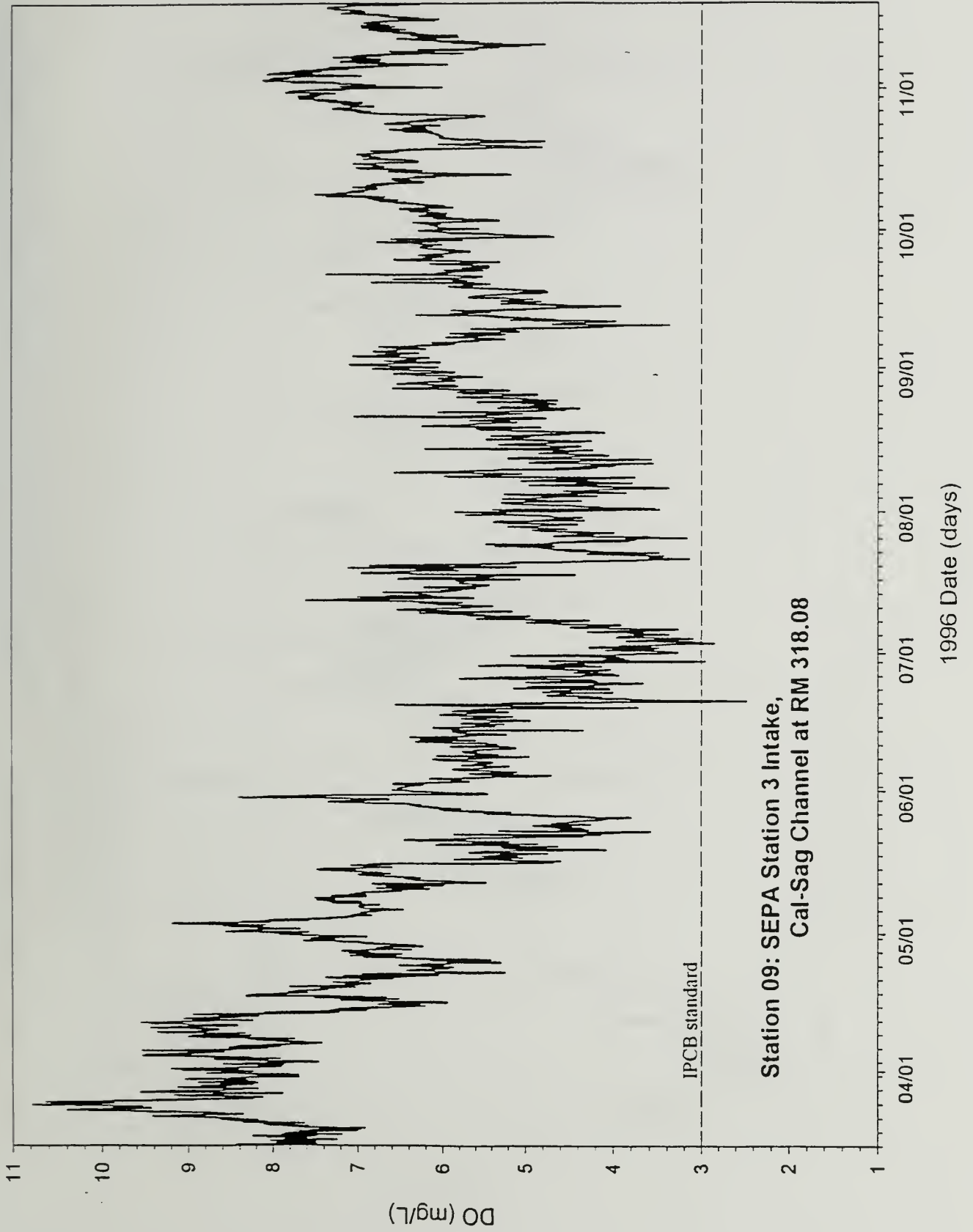

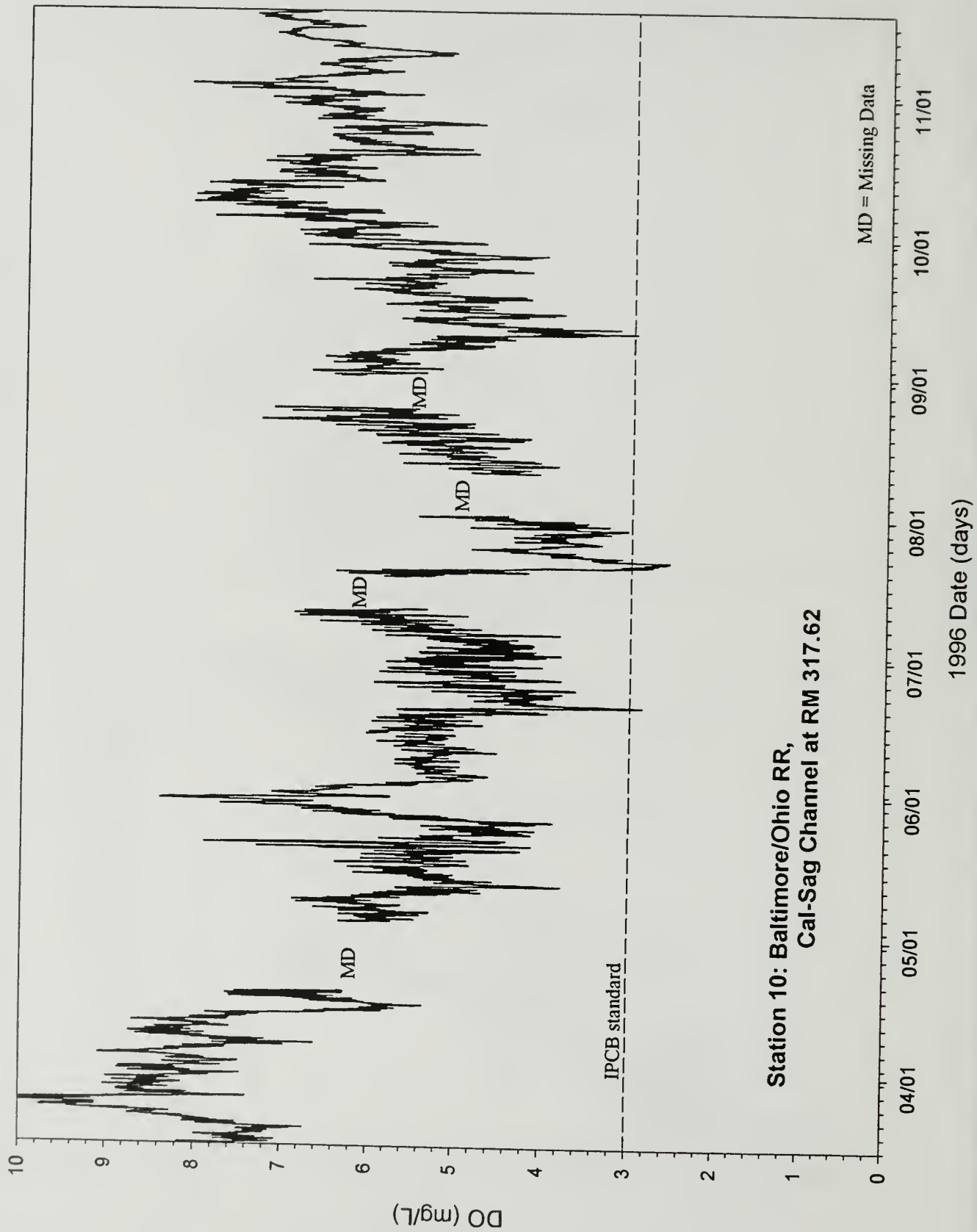

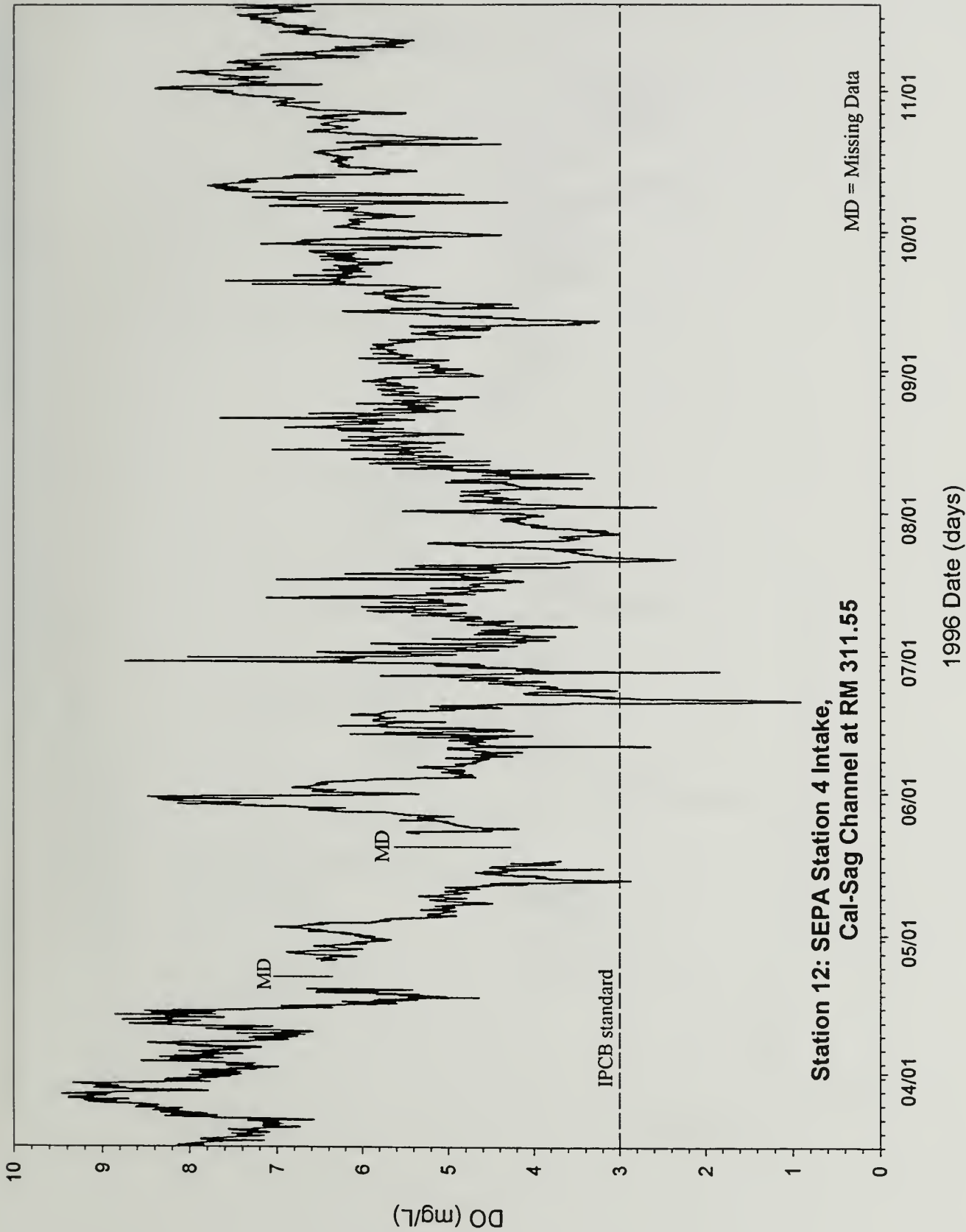

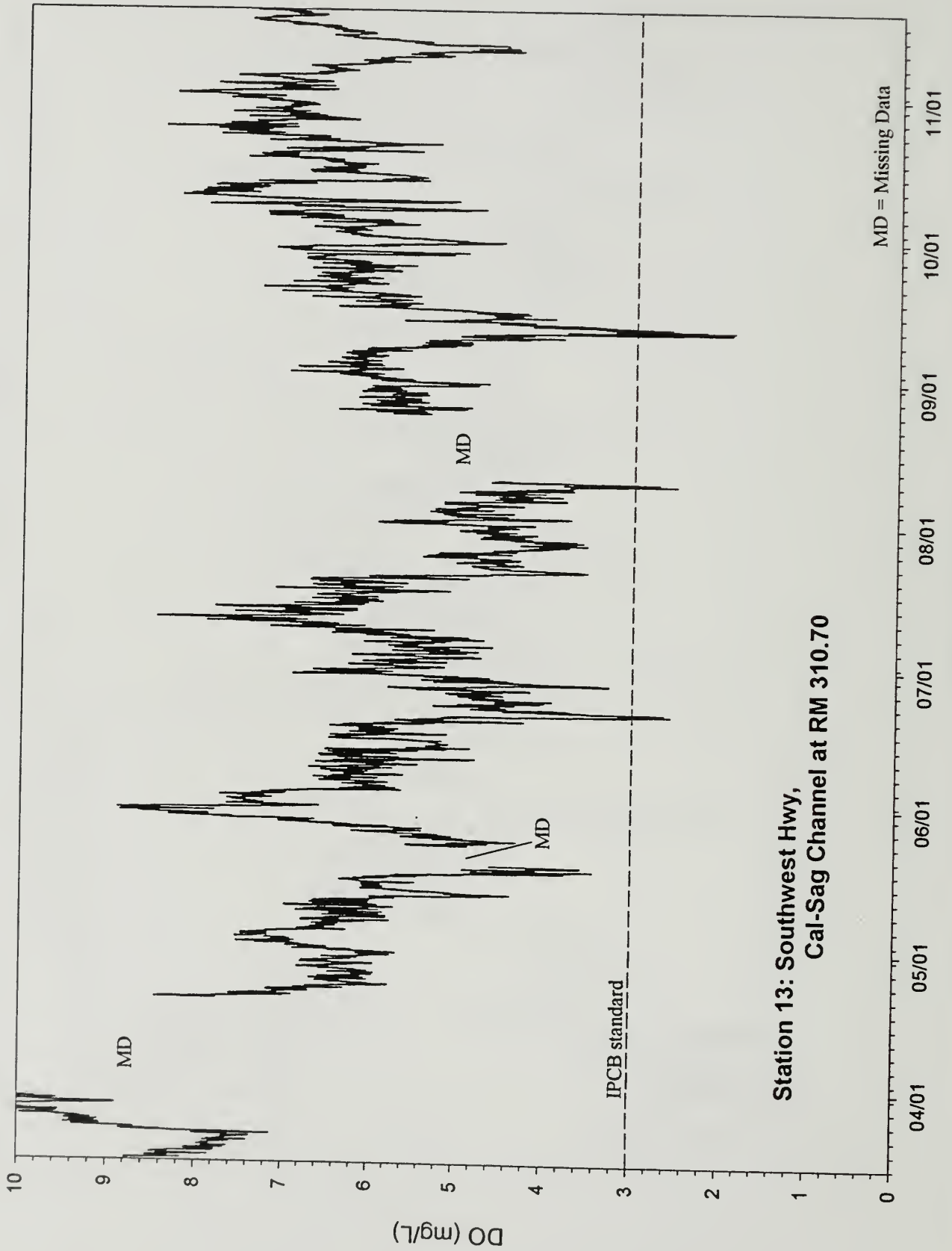

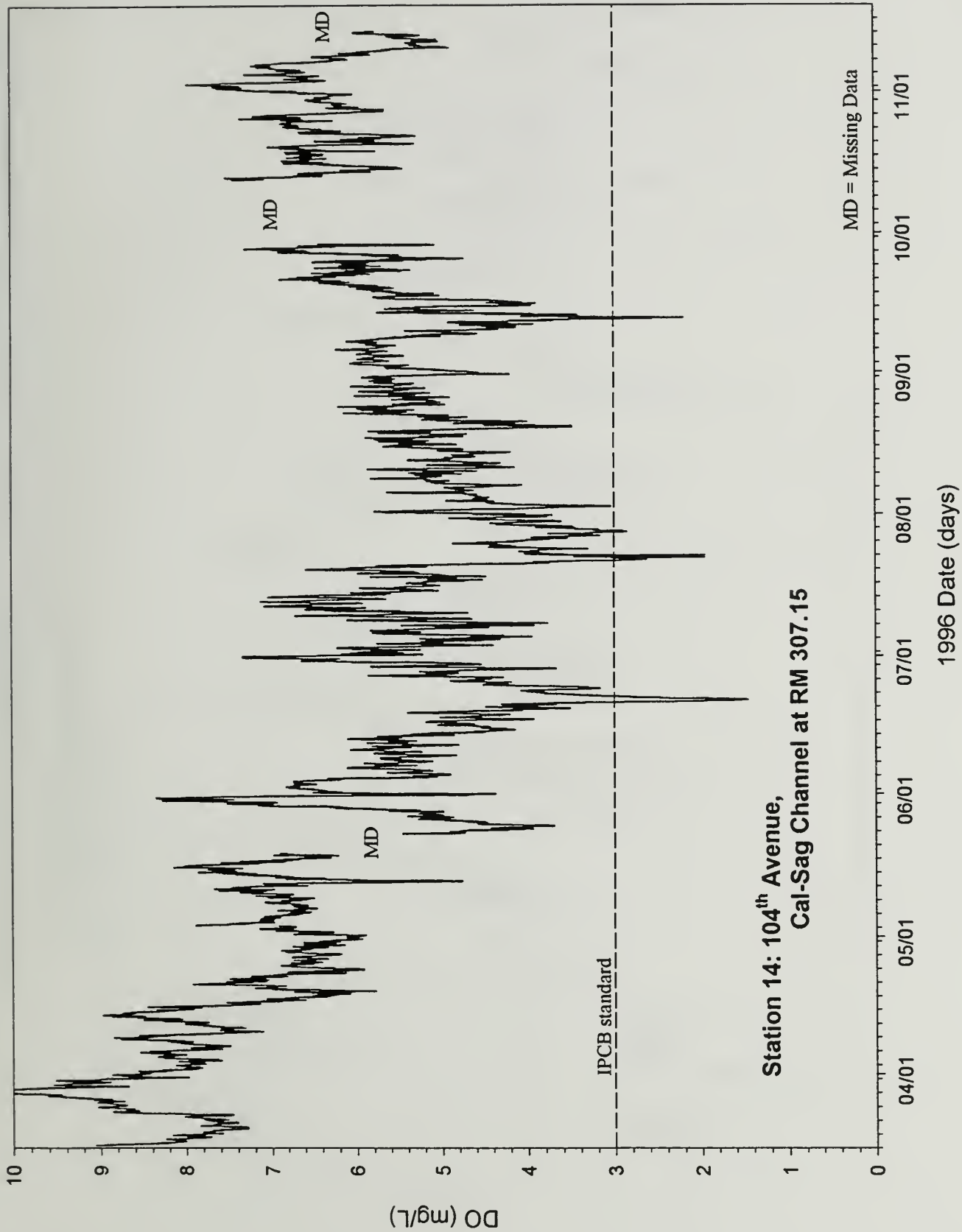

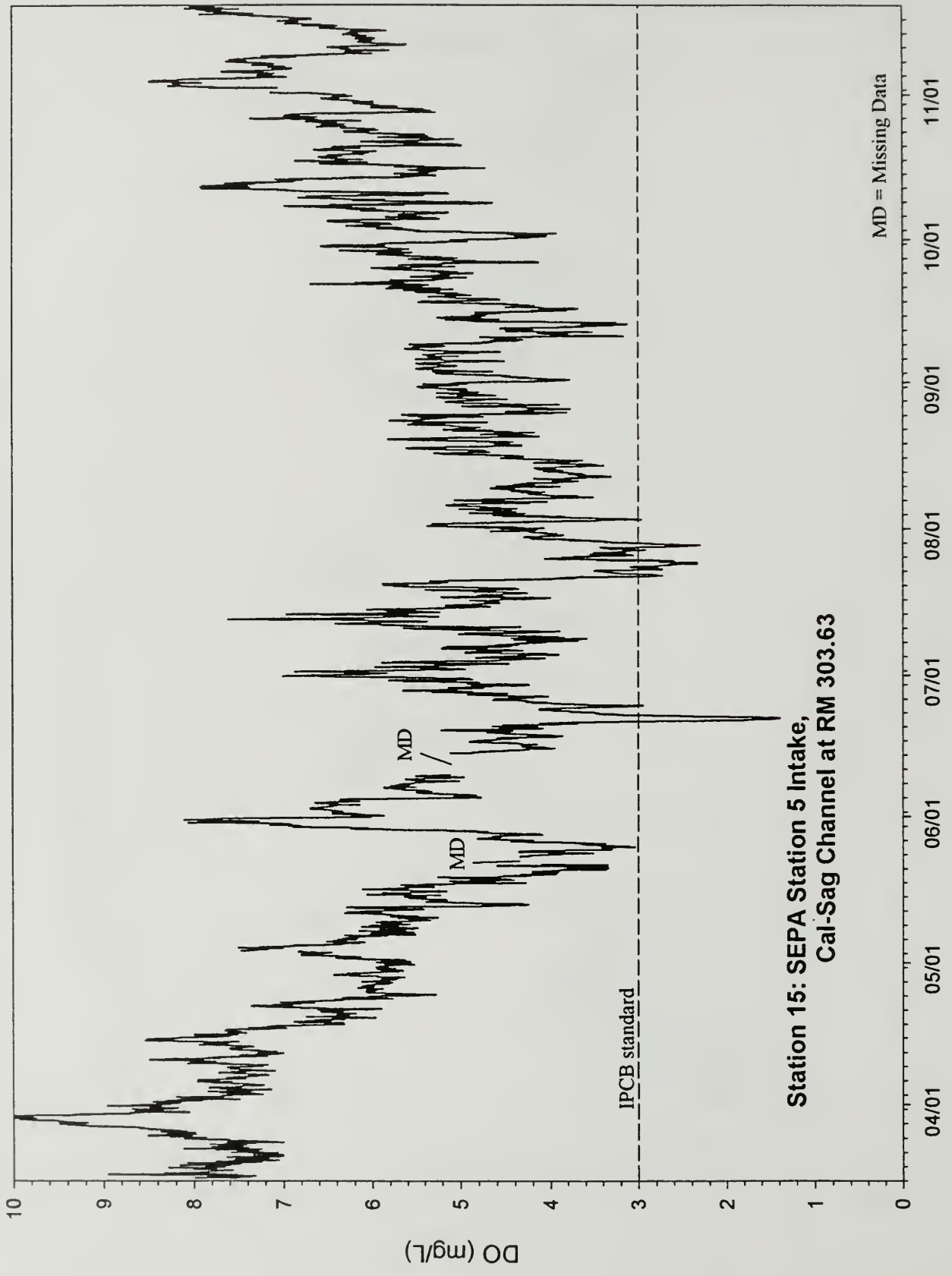

**Station 15: SEPA Station 5 Intake,
Cai-Sag Channel at RM 303.63**

MD = Missing Data

1996 Date (days)

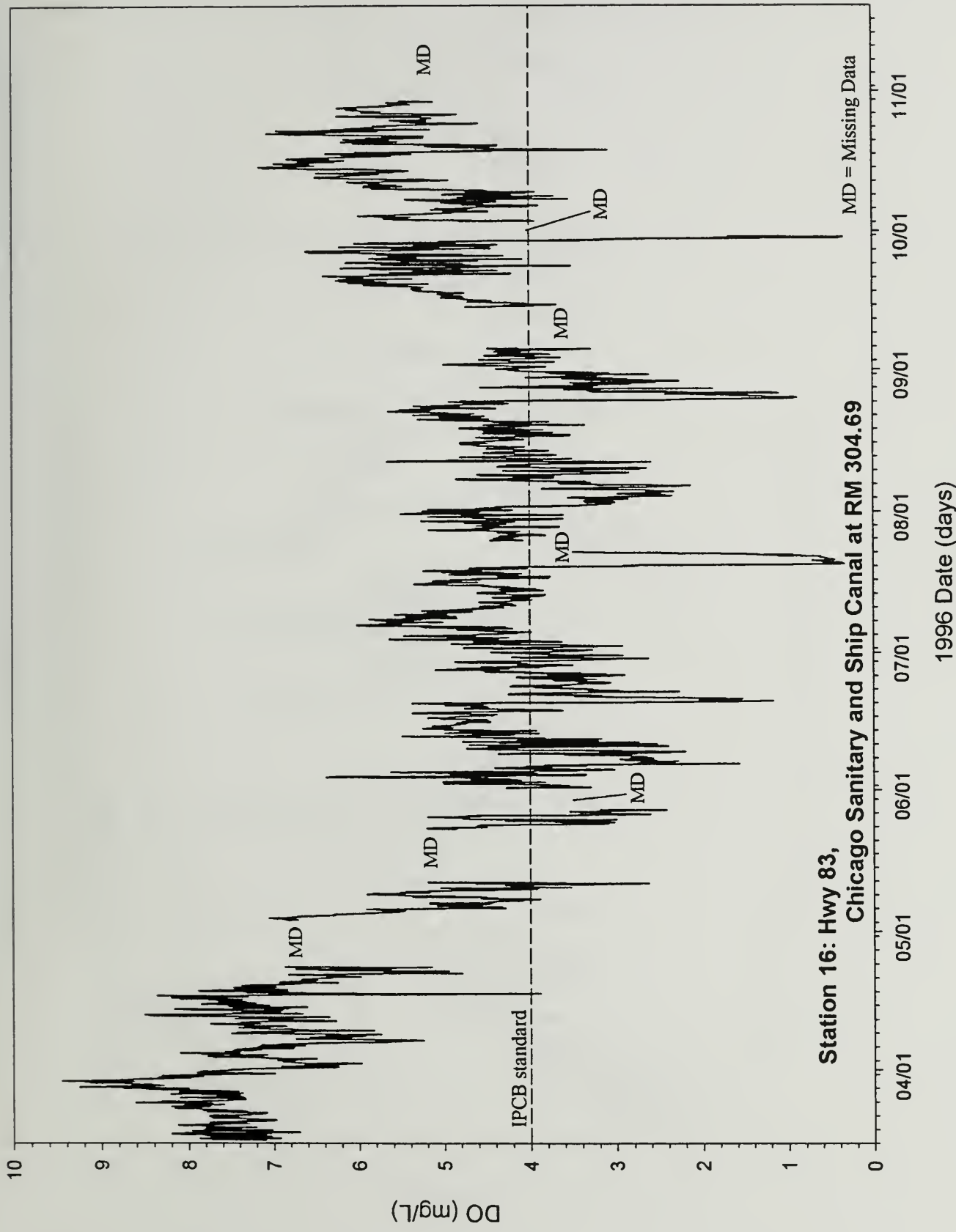

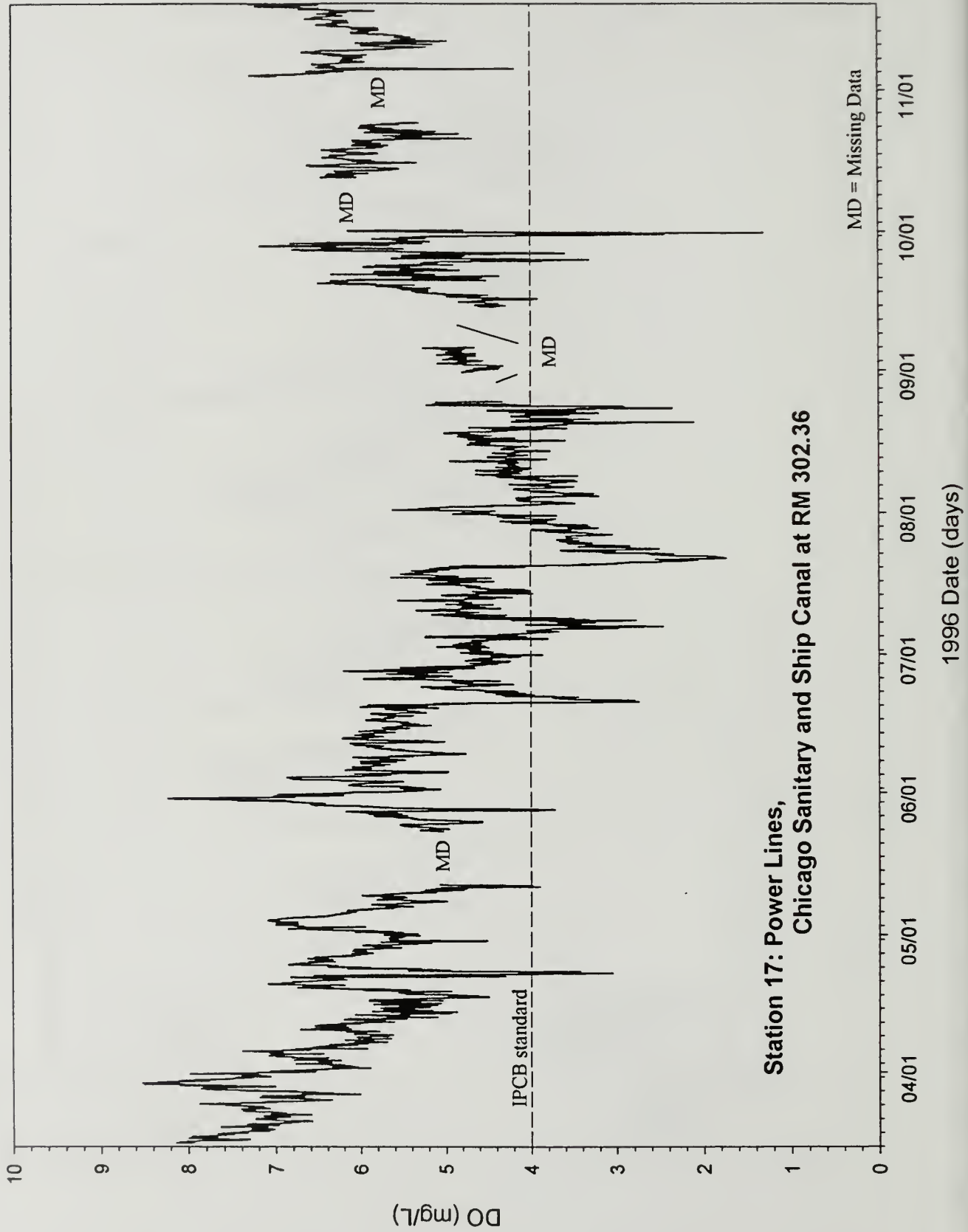

**Station 17: Power Lines,
Chicago Sanitary and Ship Canal at RM 302.36**

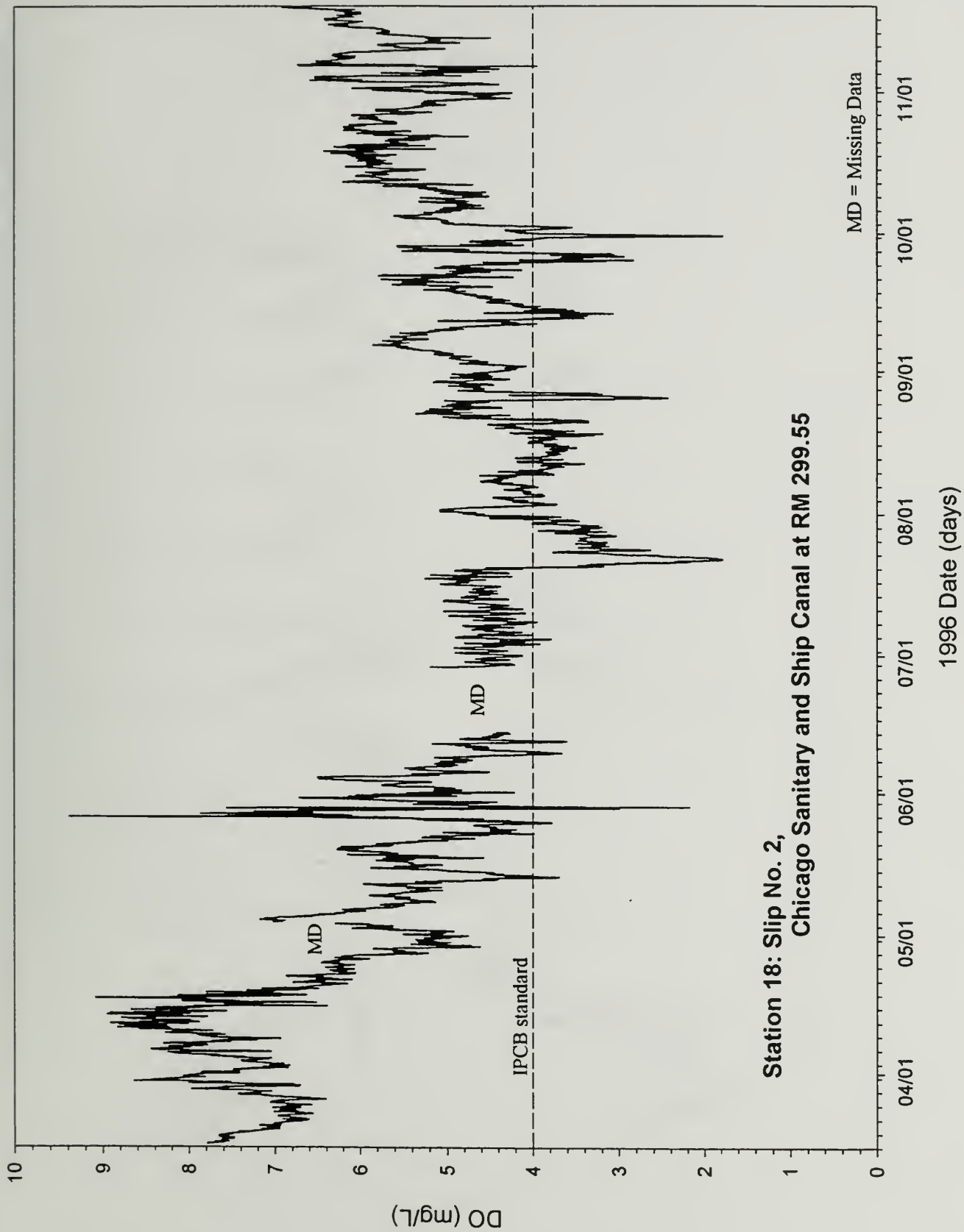

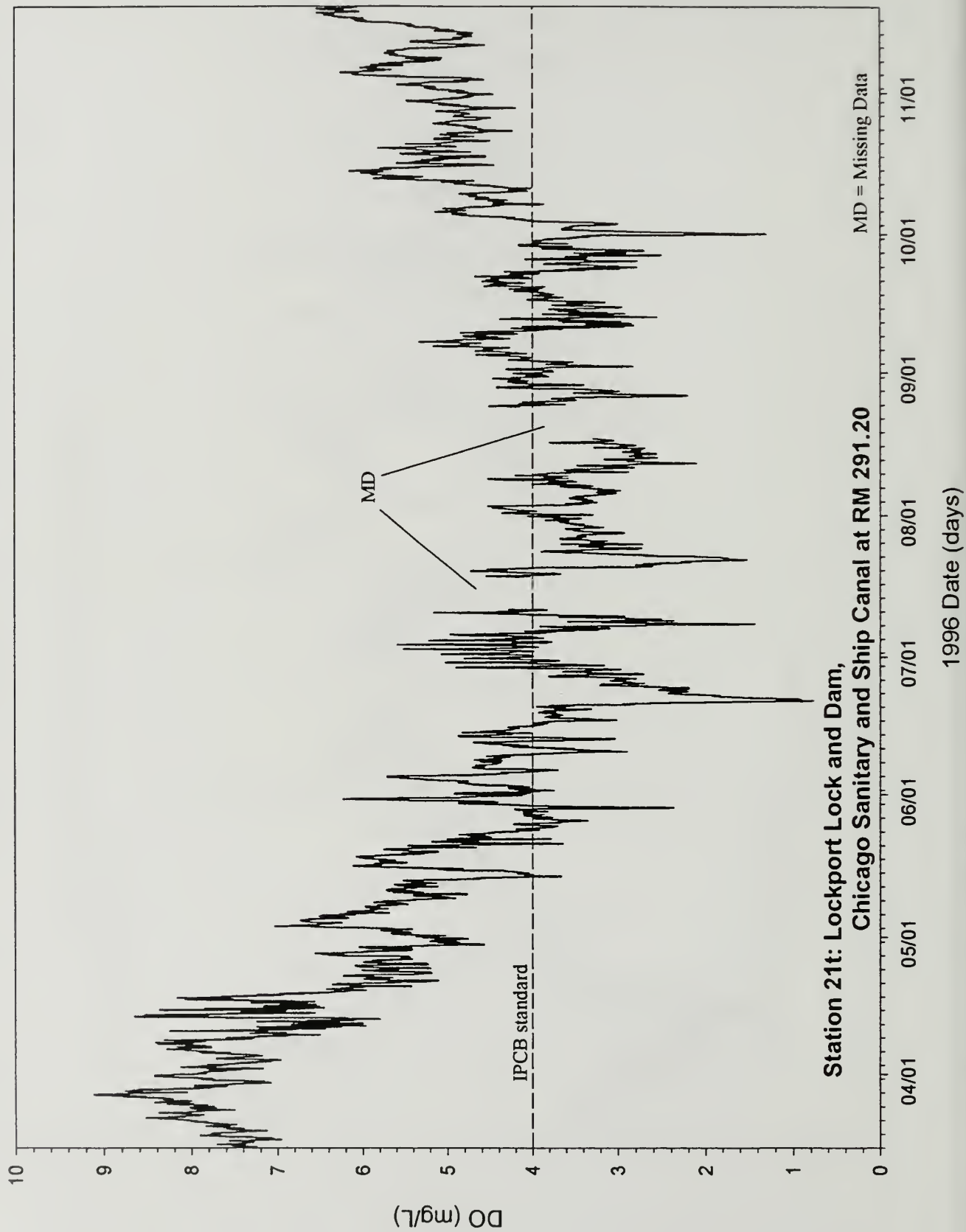

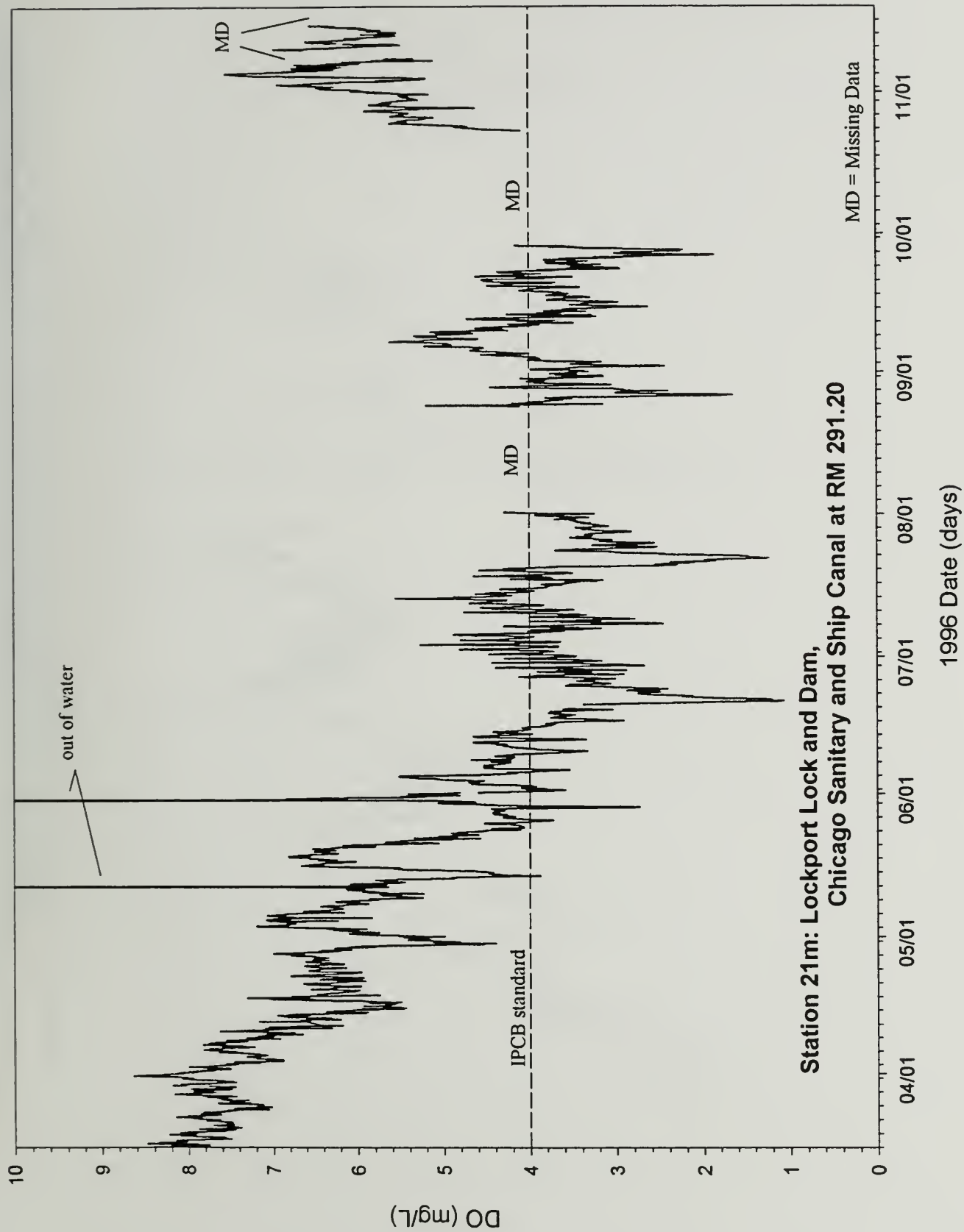

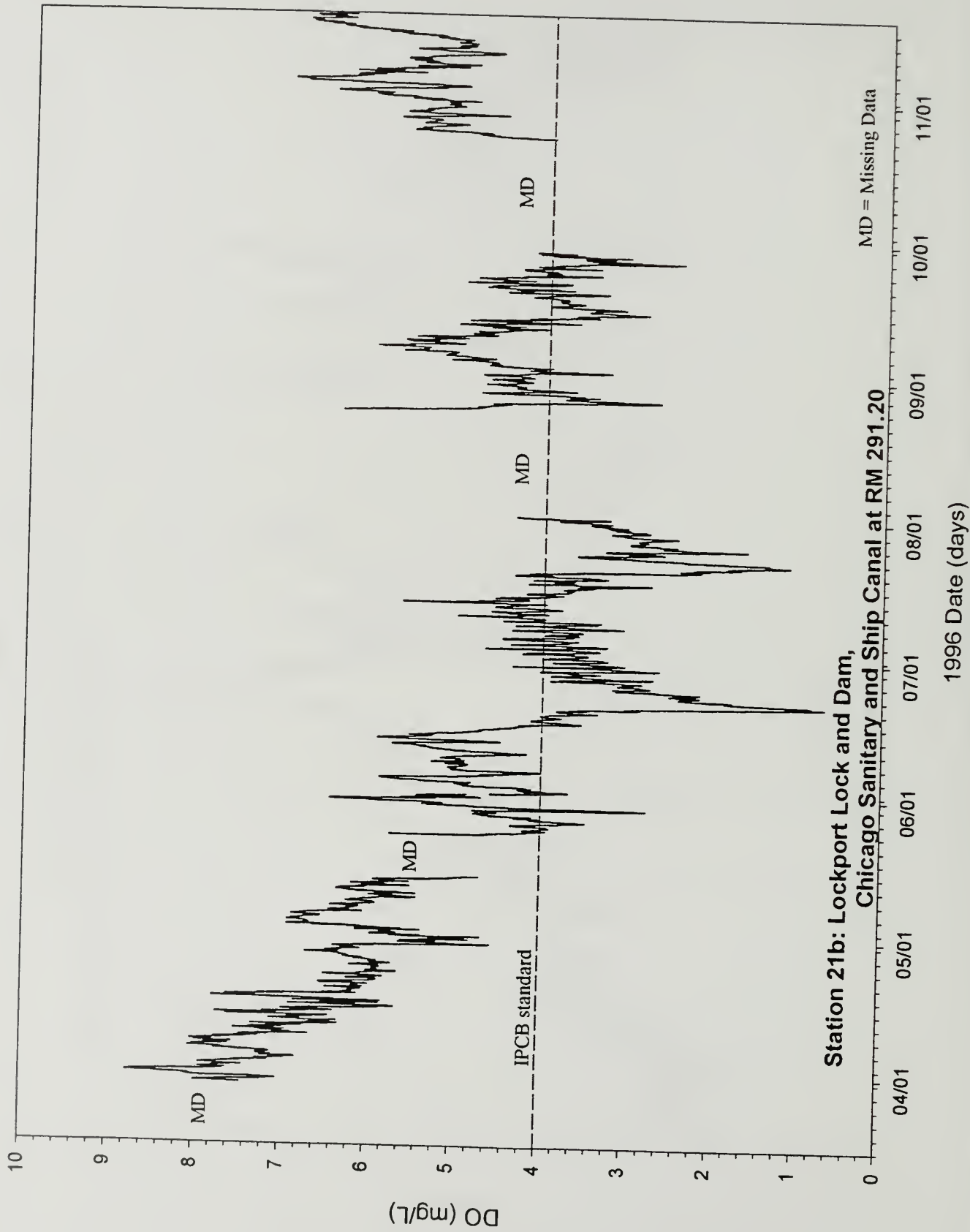

Appendix C
Summary of Continuous Monitoring for pH and
Specific Conductance and Manually Collected Nitrogen Data

**Appendix C.
pH**

<i>Station</i>	<i>Period 2</i> <i>4/19 - 5/30/1996</i>			<i>Period 3</i> <i>5/31 - 7/03/1996</i>			<i>Period 4</i> <i>7/04 - 9/25/1996</i>		
	<i>Min</i>	<i>Mean</i>	<i>Max</i>	<i>Min</i>	<i>Mean</i>	<i>Max</i>	<i>Min</i>	<i>Mean</i>	<i>Max</i>
1	7.64	7.77	7.86	7.58	7.75	7.93	7.42	7.84	8.26
2	7.54	7.60	7.70	7.40	7.59	7.83	7.16	7.95	8.40
6	-	-	-	6.67	7.06	7.61	6.71	7.20	7.90
7	6.64	6.93	7.14	6.62	7.00	7.20	6.59	7.04	8.53
9	7.01	7.20	7.33	6.89	7.12	7.31	6.85	7.18	7.56
10	6.96	7.13	7.37	6.72	7.02	7.21	6.84	7.14	7.53
12	6.83	7.09	7.29	6.64	7.03	7.47	6.46	7.14	7.51
13	6.97	7.20	7.34	6.83	7.14	7.31	6.76	7.16	7.58
14	6.96	7.19	7.38	6.86	7.06	7.25	6.57	7.11	7.47
15	6.73	6.96	7.21	6.73	7.12	7.41	6.11	7.14	7.50
16	5.76	6.76	6.98	6.45	6.90	7.64	6.52	6.82	7.11
17	6.78	6.90	7.03	6.75	6.92	7.06	6.65	6.99	7.35
18	6.89	6.99	7.15	6.86	6.97	7.10	6.58	6.94	7.22
21t	6.82	6.98	7.19	6.80	7.09	7.20	6.66	6.94	7.25
21m	6.60	7.09	7.76	6.47	7.09	7.24	6.64	7.01	7.22
21b	7.10	7.11	7.13	6.92	7.09	7.20	6.48	6.95	7.22

<i>Station</i>	<i>Period 5</i> <i>9/26 - 10/31/1996</i>			<i>Period 6</i> <i>11/01 - 11/19/1996</i>			<i>Period 2-6</i> <i>4/19 - 11/19/1996</i>		
	<i>Min</i>	<i>Mean</i>	<i>Max</i>	<i>Min</i>	<i>Mean</i>	<i>Max</i>	<i>Min</i>	<i>Mean</i>	<i>Max</i>
1	7.79	8.17	8.33	7.37	7.92	8.20	7.37	7.91	8.33
2	7.81	7.98	8.34	7.77	7.95	8.08	7.16	7.88	8.40
6	6.48	6.79	7.20	6.54	6.77	6.94	6.48	7.05	7.90
7	6.73	7.09	7.41	6.70	6.94	7.25	6.59	7.02	8.53
9	6.80	7.21	7.47	7.06	7.21	7.40	6.80	7.18	7.56
10	6.75	7.09	7.50	7.11	7.28	7.47	6.72	7.12	7.53
12	6.69	7.06	7.50	7.02	7.19	7.30	6.46	7.10	7.51
13	6.89	7.25	7.57	6.86	7.11	7.39	6.76	7.17	7.58
14	6.93	7.23	7.56	7.26	7.40	7.56	6.57	7.15	7.56
15	6.92	7.25	7.62	7.15	7.38	7.58	6.11	7.17	7.62
16	6.58	6.87	7.12	6.54	6.89	7.11	5.76	6.85	7.64
17	6.88	7.09	7.57	6.97	7.17	8.07	6.65	7.01	8.07
18	6.69	6.97	7.20	6.86	7.10	7.26	6.58	6.97	7.26
21t	6.71	6.99	7.25	6.58	7.01	7.22	6.58	6.99	7.25
21m	6.73	7.07	7.16	6.77	6.92	7.13	6.47	7.03	7.76
21b	6.46	7.16	7.27	6.71	6.99	7.19	6.46	7.01	7.27

Notes: The pH was not monitored during Period 1.

21t = near surface, 21m = mid-depth, 21b = bottom

Appendix C. (continued)
Specific Conductance (mS/cm)
at 25°C

Station	Period 1 3/16 - 4/18/1996			Period 2 4/19 - 5/30/1996			Period 3 5/31 - 7/03/1996		
	Min	Mean	Max	Min	Mean	Max	Min	Mean	Max
1	0.427	0.480	0.547	0.493	0.549	0.587	0.372	0.415	0.484
2	0.450	0.512	0.575	0.528	0.575	0.659	0.392	0.505	0.704
6	0.859	1.117	1.422	0.700	0.920	1.039	0.611	0.957	1.235
7	1.183	1.221	1.243	0.435	1.100	1.258	0.511	1.017	1.289
9	0.915	1.206	1.394	0.457	0.935	1.175	0.521	0.924	1.141
10	1.121	1.316	1.464	0.344	0.808	1.058	0.568	0.913	1.028
12	1.205	1.333	1.496	0.521	0.957	1.170	0.544	0.926	1.057
13	1.167	1.381	1.499	0.398	0.937	1.177	0.558	0.924	1.068
14	1.154	1.298	1.490	0.390	0.926	1.250	0.543	0.908	1.088
15	1.100	1.259	1.499	0.486	0.864	1.163	0.485	0.850	1.089
16	0.794	0.983	1.295	0.616	0.827	0.982	0.433	0.777	0.905
17	0.849	1.105	1.497	0.504	0.877	1.034	0.498	0.811	0.937
18	0.861	1.048	1.367	0.464	0.847	1.038	0.641	0.796	0.912
21t	0.873	1.116	1.490	0.538	0.916	1.092	0.510	0.795	0.930
21m	0.868	1.132	1.499	0.000	0.883	1.100	0.510	0.770	0.880
21b	0.886	1.172	1.500	0.508	0.882	1.061	0.510	0.778	0.910

Station	Period 4 7/04 - 9/25/1996			Period 5 9/26 - 10/31/1996			Period 6 11/01 - 11/19/1996			Period 1-6 3/16 - 11/19/1996		
	Min	Mean	Max	Min	Mean	Max	Min	Mean	Max	Min	Mean	Max
1	0.27	0.33	0.44	0.26	0.29	0.34	0.288	0.317	0.358	0.262	0.408	0.587
2	0.28	0.36	0.51	0.24	0.35	0.38	0.346	0.381	0.410	0.235	0.446	0.704
6	0.39	0.66	1.01	0.55	0.70	0.84	0.609	0.846	0.979	0.390	0.824	1.422
7	0.28	0.75	1.10	0.62	0.71	0.92	0.601	0.880	0.995	0.284	0.879	1.289
9	0.36	0.68	0.1	0.46	0.68	0.96	0.700	0.905	1.020	0.360	0.846	1.394
10	0.23	0.69	0.93	0.45	0.64	0.86	0.670	0.828	0.930	0.234	0.842	1.464
12	0.30	0.72	0.97	0.49	0.70	0.92	0.690	0.850	0.980	0.302	0.872	1.496
13	0.31	0.74	0.96	0.53	0.71	0.92	0.680	0.837	0.994	0.309	0.844	1.499
14	0.36	0.68	0.95	0.55	0.69	0.90	0.670	0.816	0.990	0.363	0.855	1.490
15	0.34	0.65	0.91	0.49	0.66	0.86	0.650	0.811	0.970	0.344	0.803	1.499
16	0.32	0.61	0.80	0.46	0.64	0.73	0.733	0.885	1.010	0.322	0.740	1.295
17	0.36	0.63	0.83	0.38	0.62	0.80	0.540	0.671	0.780	0.363	0.757	1.497
18	0.46	0.64	0.92	0.48	0.67	0.82	0.550	0.659	0.720	0.460	0.755	1.367
21t	0.42	0.65	0.90	0.43	0.64	0.76	0.580	0.710	0.810	0.420	0.788	1.490
21m	0.32	0.61	0.80	0.56	0.68	0.76	.0580	0.682	0.740	0.000	0.792	1.499
21b	0.40	0.70	0.81	0.64	0.70	0.78	0.590	0.731	0.820	0.400	0.831	1.500

Note: 21t = near surface, 21m = mid-depth, 21b = bottom

Appendix C. (continued)
Nitrogen Data (mg/L) Collected March 28-November 13, 1996

<i>Station</i>	<i>Count</i>	<i>Min</i>	<i>Mean</i>	<i>Max</i>	<i>S.D.</i>	<i>Count</i>	<i>Min</i>	<i>Mean</i>	<i>Max</i>	<i>S.D.</i>
		NH ₃ -N					NO ₂ -N			
1	10	0.00	0.206	0.51	0.192	10	0.00	0.030	0.05	0.017
2	10	0.03	0.237	0.73	0.236	10	0.01	0.032	0.05	0.015
6	10	0.21	1.054	3.66	1.130	10	0.03	0.123	0.22	0.060
7	10	0.24	1.091	3.56	1.070	10	0.05	0.141	0.22	0.065
9	10	0.32	0.699	2.15	0.552	10	0.08	0.125	0.19	0.035
10	10	0.35	0.590	1.11	0.298	10	0.08	0.108	0.14	0.022
12	10	0.24	0.506	1.23	0.297	10	0.04	0.118	0.26	0.057
13	10	0.22	0.534	1.20	0.285	10	0.04	0.124	0.26	0.057
14	10	0.24	0.555	1.33	0.325	10	0.05	0.129	0.21	0.051
15	10	0.20	0.557	1.68	0.420	10	0.07	0.119	0.19	0.036
16	10	0.18	0.650	2.01	0.522	10	0.09	0.182	0.35	0.100
17	10	0.23	0.639	1.97	0.487	10	0.09	0.171	0.30	0.068
18	10	0.32	0.579	1.43	0.325	10	0.08	0.151	0.21	0.037
21	10	0.10	0.652	2.07	0.540	10	0.10	0.178	0.36	0.083
		NO ₃ -N					TKN			
1	10	0.26	0.538	0.99	0.231	10	0.31	0.605	1.12	0.230
2	10	0.23	0.535	1.12	0.324	10	0.32	0.681	1.18	0.263
6	10	0.50	3.333	5.76	1.887	10	1.22	2.972	6.62	1.939
7	10	0.67	3.459	5.83	1.838	10	1.08	2.405	6.19	1.576
9	10	1.86	3.161	5.50	1.140	10	1.33	2.030	4.15	0.847
10	10	1.68	2.917	4.32	0.928	10	0.89	1.879	4.09	0.931
12	10	1.67	2.512	3.68	0.594	10	0.97	1.830	3.20	0.639
13	10	1.68	2.609	3.79	0.698	10	0.93	1.727	2.49	0.494
14	10	1.66	2.802	4.54	0.971	10	1.26	1.763	2.73	0.445
15	10	1.48	3.051	6.70	1.571	10	0.92	1.708	3.58	0.712
16	10	3.24	5.202	7.83	1.665	10	0.57	1.763	3.97	0.947
17	10	2.44	4.935	7.25	1.790	10	0.98	1.765	3.86	0.804
18	10	2.59	4.530	6.35	1.457	10	0.75	1.785	2.89	0.583
21	10	2.20	4.129	6.62	1.452	10	1.00	1.907	4.42	0.968

Appendix C. (concluded)
Nitrogen Data from Sample Collection

<i>Nitrogen species</i>		<i>Date</i>									
		<i>3/28</i>	<i>4/23</i>	<i>5/22</i>	<i>6/19</i>	<i>7/2</i>	<i>7/24</i>	<i>7/31</i>	<i>9/4</i>	<i>10/22</i>	<i>11/13</i>
NH ₃ -N	Count	14	14	14	14	14	14	14	14	14	14
	Min	0.47	0.38	0.27	0.03	0.03	0.06	0.19	0.09	0.14	0.00
	Mean	1.757	0.609	0.489	0.393	0.287	0.588	0.433	0.499	0.429	0.622
	Max	3.66	1.08	0.89	0.59	0.49	0.88	0.75	1.33	0.65	2.46
	S.D.	0.930	0.196	0.161	0.178	0.124	0.273	0.148	0.374	0.178	0.787
NO ₂ -N	Count	14	14	14	14	14	14	14	14	14	14
	Min	0.02	0.04	0.04	0.04	0.02	0.05	0.04	0.00	0.02	0.01
	Mean	0.166	0.124	0.116	0.111	0.126	0.164	0.158	0.059	0.094	0.119
	Max	0.36	0.20	0.20	0.16	0.21	0.30	0.30	0.10	0.16	0.28
	S.D.	0.107	0.046	0.047	0.034	0.055	0.068	0.083	0.033	0.042	0.076
NO ₃ -N	Count	14	14	14	14	14	14	14	14	14	14
	Min	0.55	0.64	0.83	0.52	0.34	0.40	0.31	0.23	0.28	0.33
	Mean	4.624	3.975	3.100	2.727	2.549	2.004	2.414	2.163	3.380	4.289
	Max	7.83	6.42	5.41	4.81	5.75	4.41	3.53	4.45	6.52	7.33
	S.D.	2.209	1.853	1.317	1.221	1.703	1.106	1.006	1.483	2.008	2.129
TKN	Count	14	14	14	14	14	14	14	14	14	14
	Min	1.12	0.41	0.55	0.67	0.80	0.67	0.51	0.31	0.41	0.51
	Mean	3.569	1.015	1.596	1.841	1.387	2.004	1.370	1.545	1.576	1.824
	Max	6.19	1.79	2.32	6.62	1.88	2.71	1.95	3.02	2.51	4.03
	S.D.	1.494	0.391	0.477	1.423	0.287	0.607	0.426	0.793	0.603	0.984

Note: Min = minimum; Max = maximum; S.D. = standard deviation

Appendix D

Ten Most Variable Cross-sectional DO Patterns Shown with Delimiting Isopleths

Station 02 (6/05/96): Norfolk/Western RR,
 Calumet River at RM 327.69
 (DO mg/L)

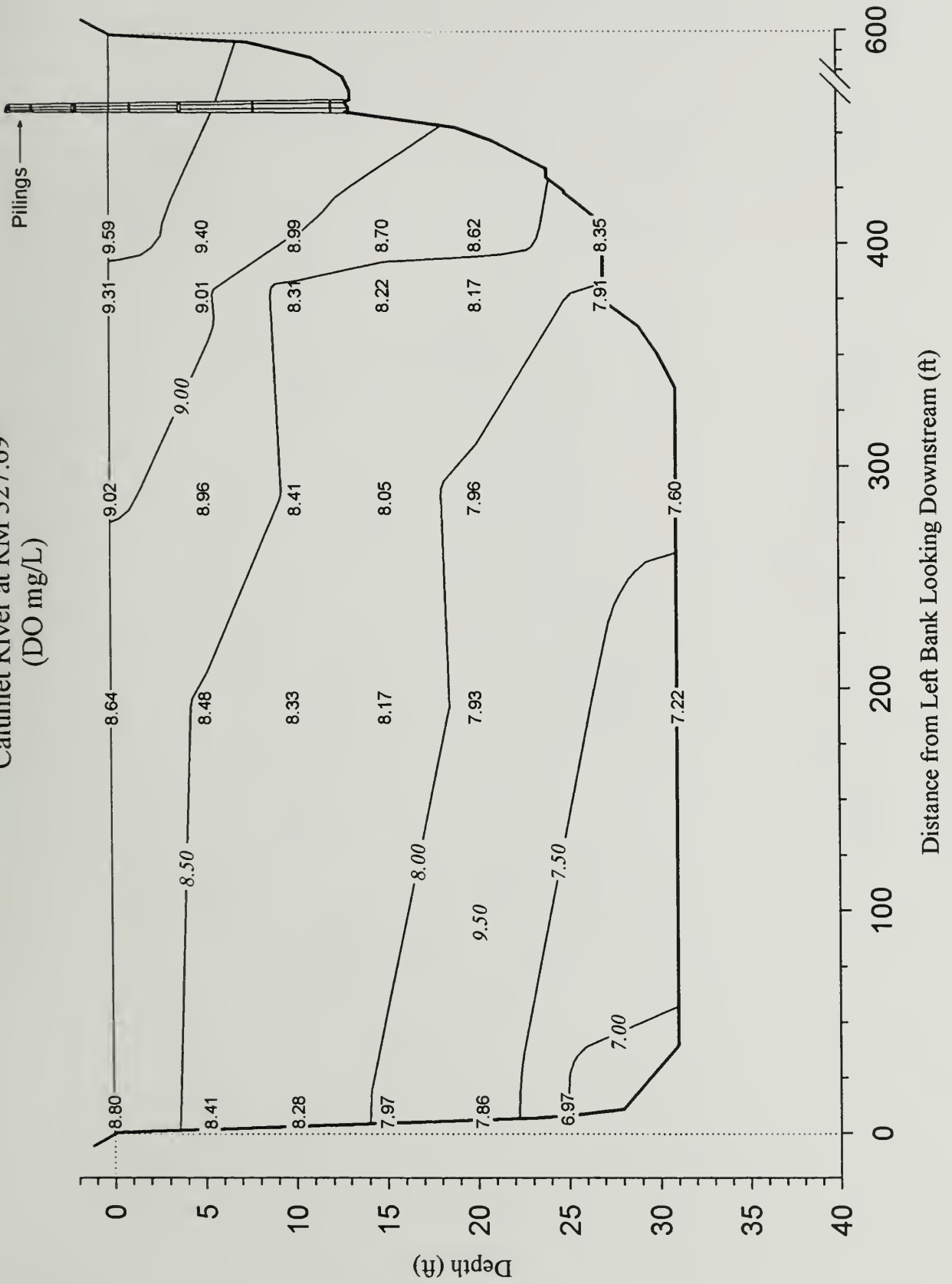

Station 06 (4/23/96): SEPA Station 2 Intake,
 Little Calumet River at RM 321.32
 (DO mg/L)

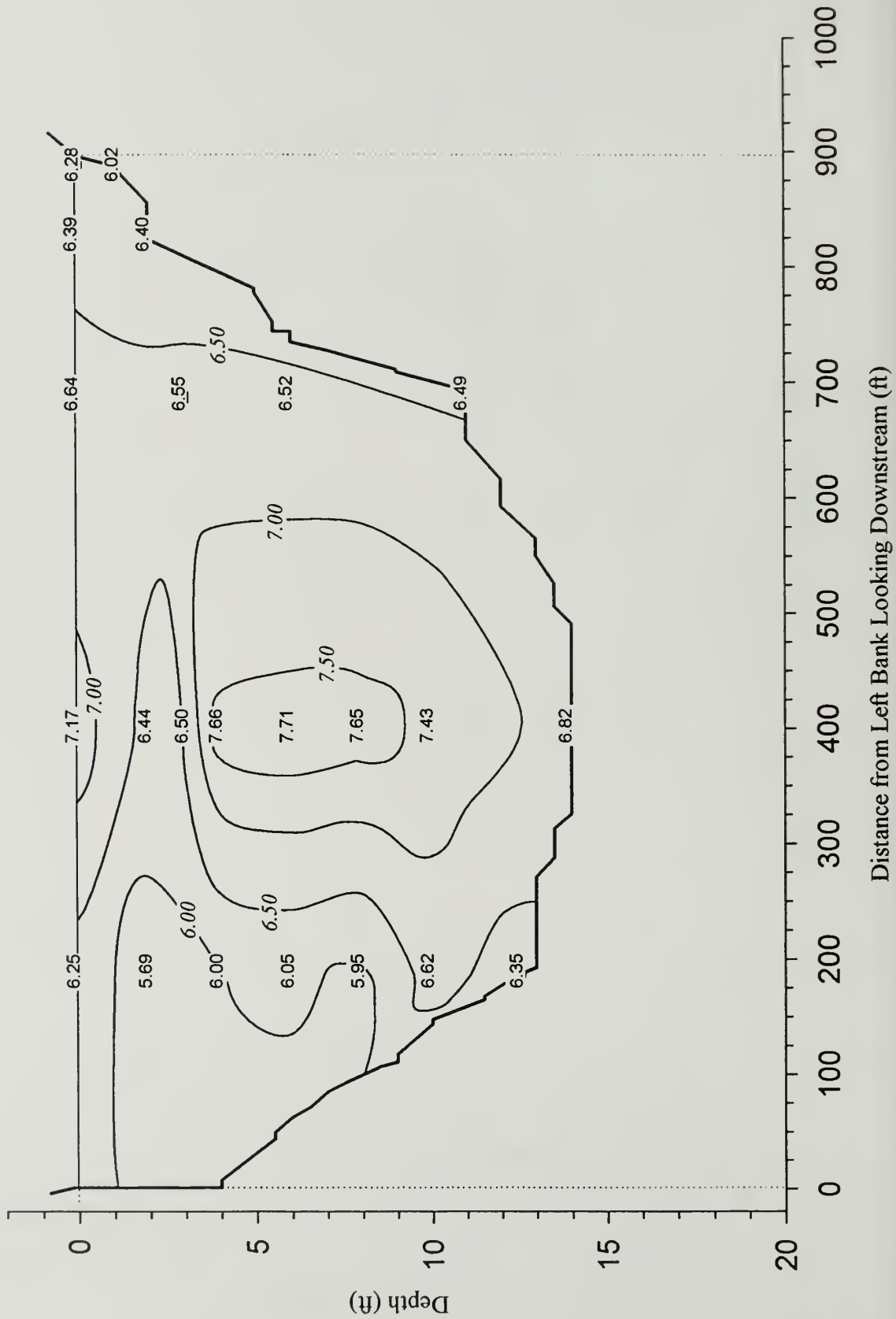

Station 06 (5/22/96): SEPA Station 2 Intake,
 Little Calumet River at RM 321.32
 (DO mg/L)

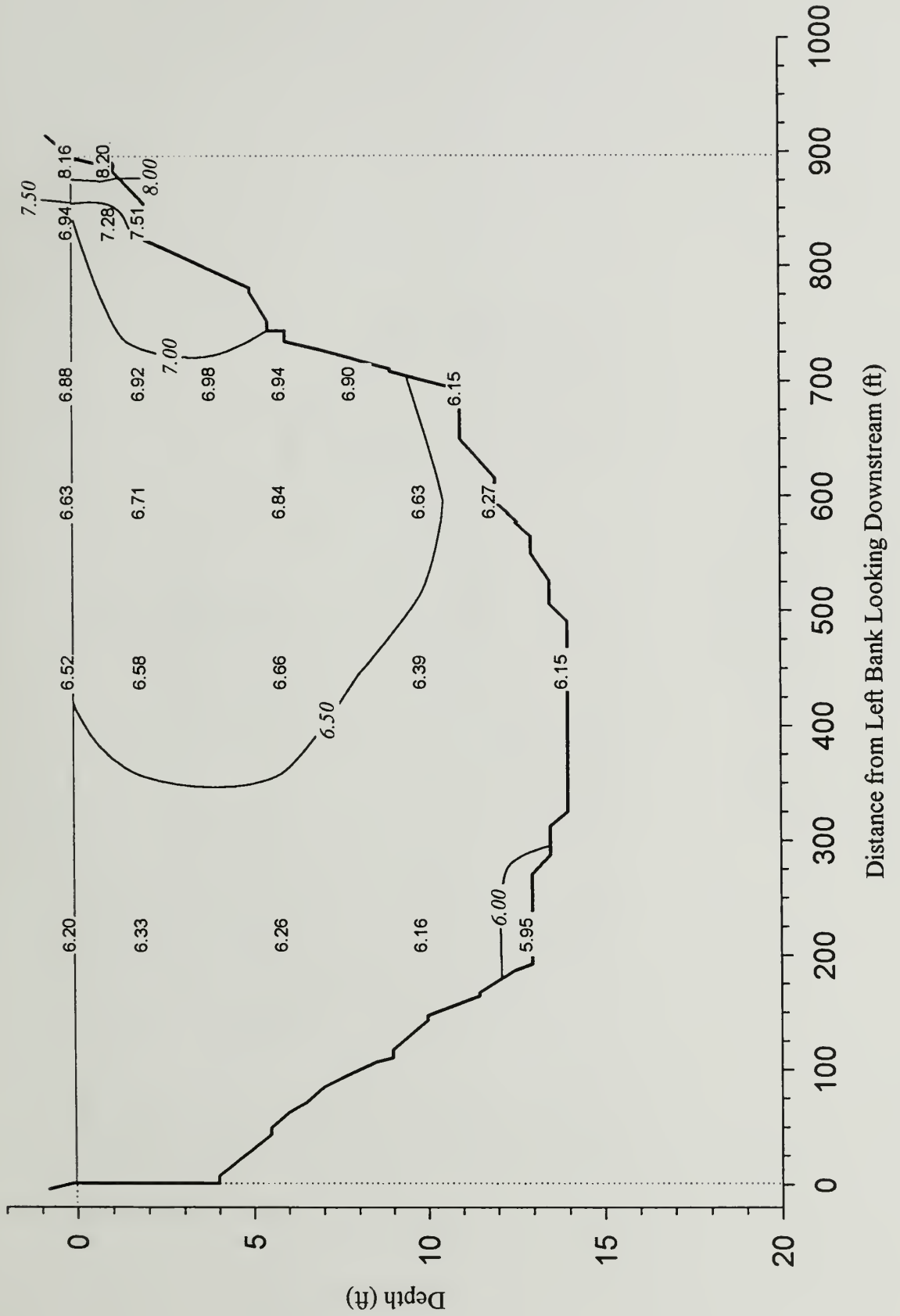

Station 07 (5/22/96): Penn Central RR,
 Little Calumet River at RM 320.71
 (DO mg/L)

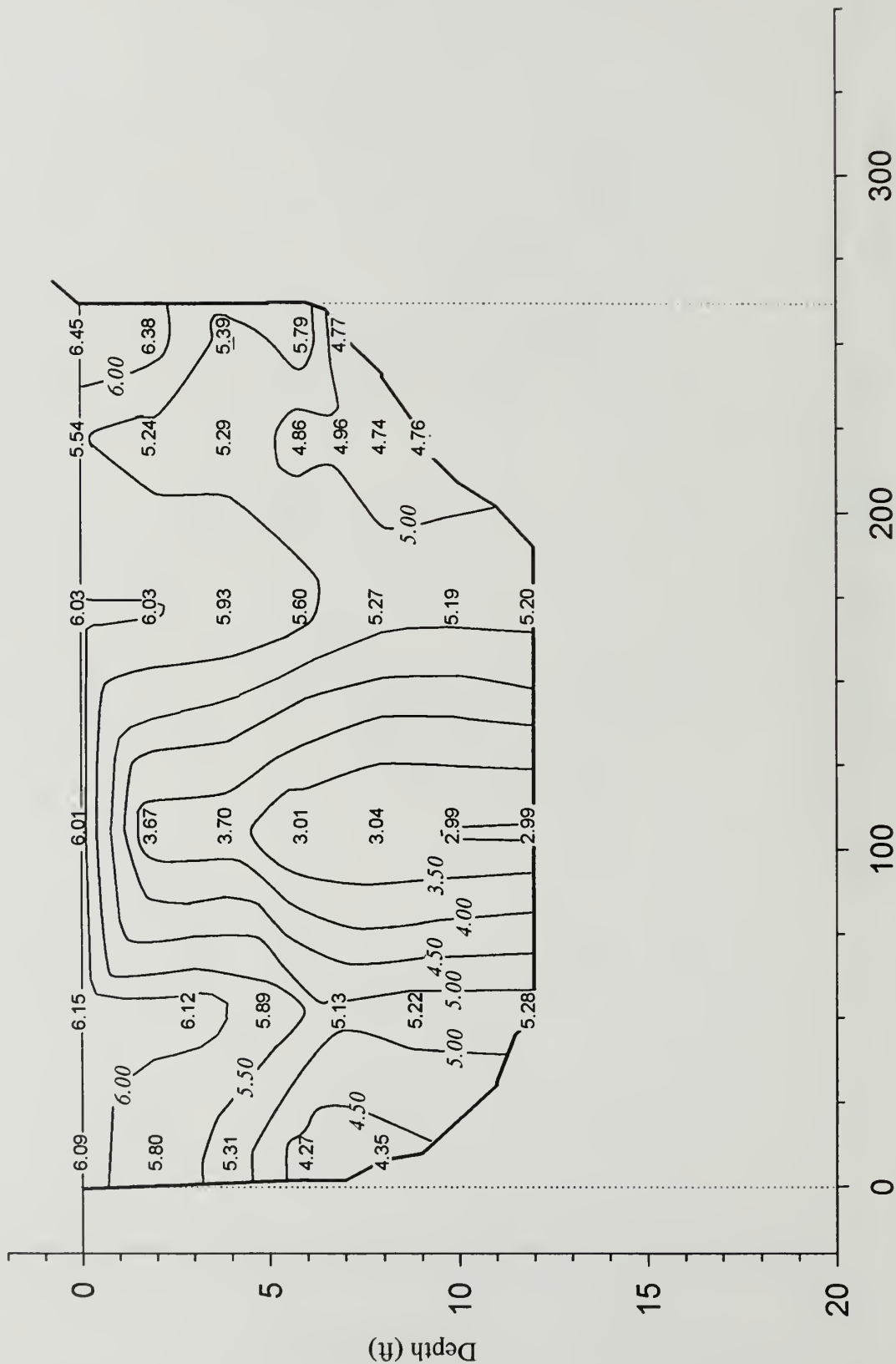

Station 10 (5/22/96): Baltimore/Ohio RR,
 Cal-Sag Channel at RM 317.62
 (DO mg/L)

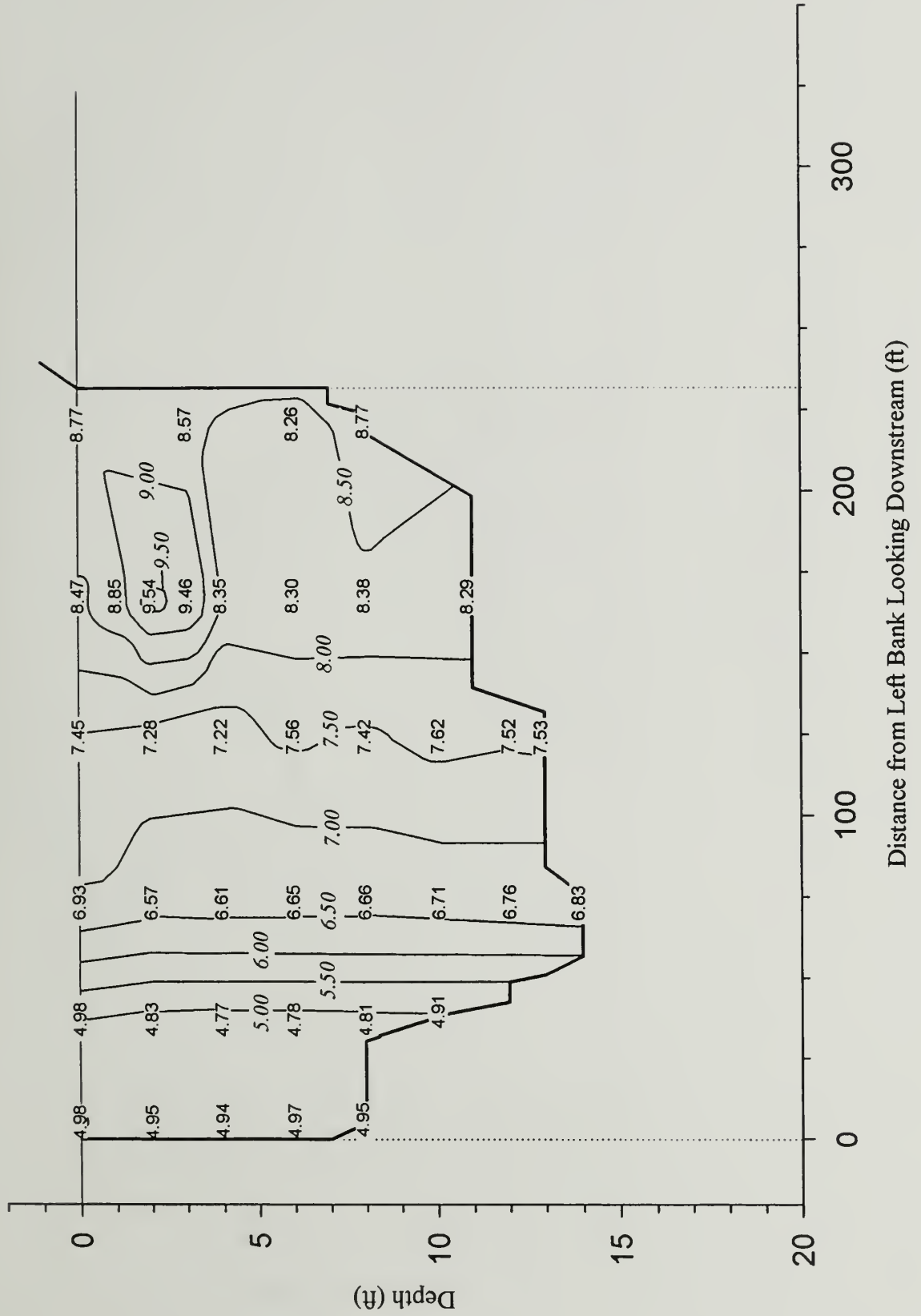

Station 10 (7/24/96, 10:00 a.m.); Baltimore/Ohio RR,
 Cal-Sag Channel at RM 317.62
 (DO mg/L)

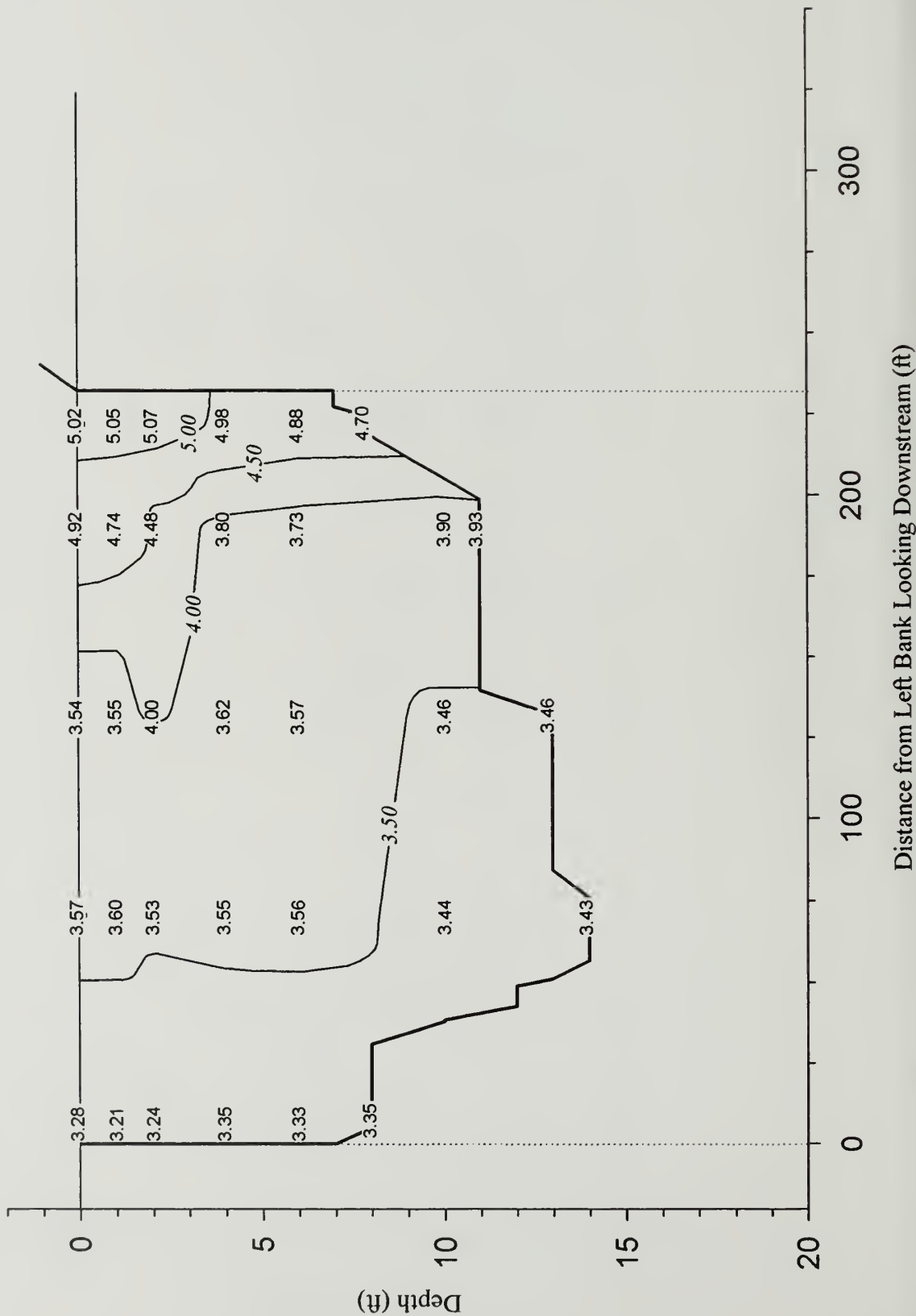

Station 10 (7/31/96): Baltimore/Ohio RR,
 Cal-Sag Channel at RM 317.62
 (DO mg/L)

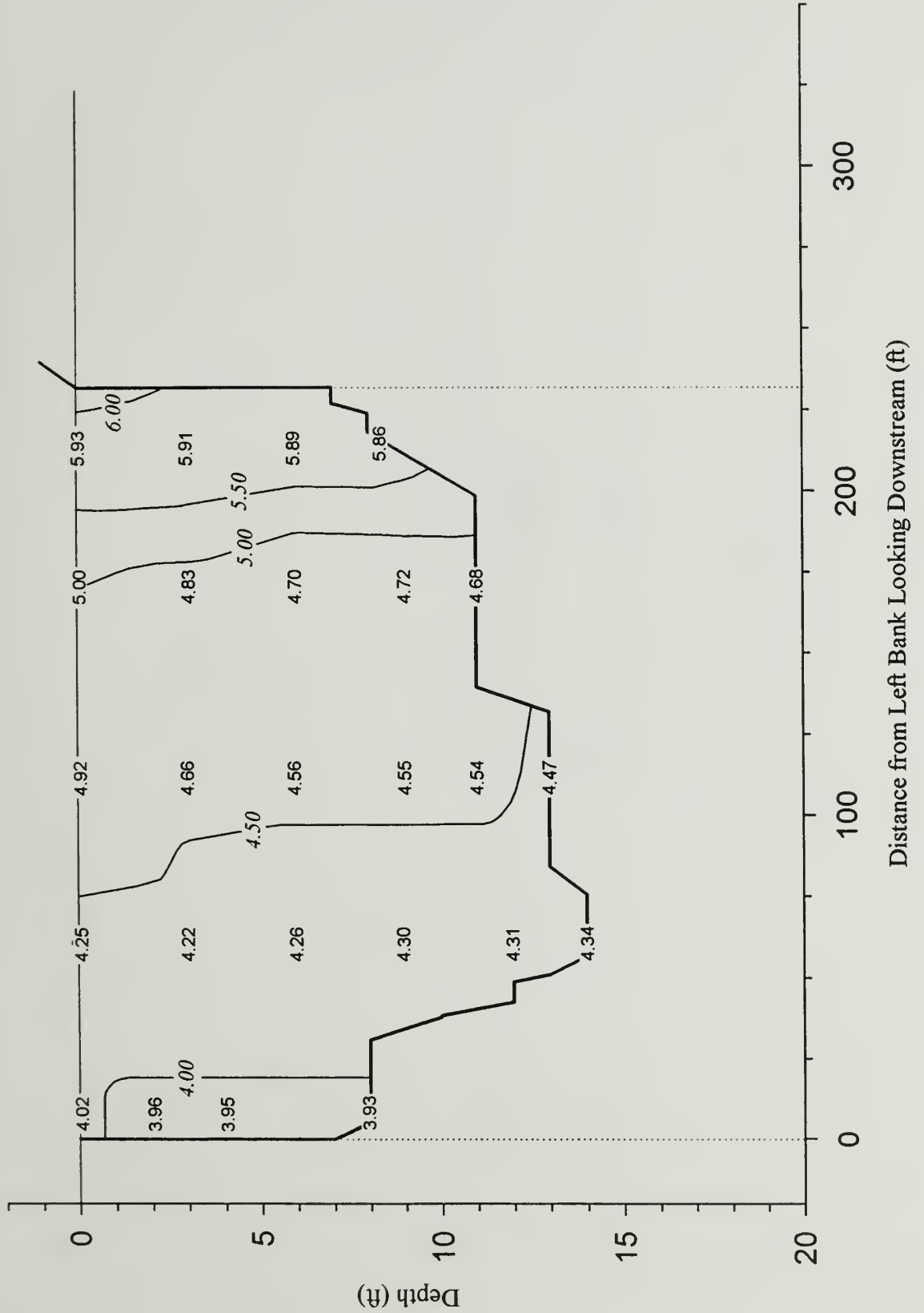

Station 13 (7/10/96): Southwest Hwy,
 Cal-Sag Channel at RM 310.70
 (DO mg/L)

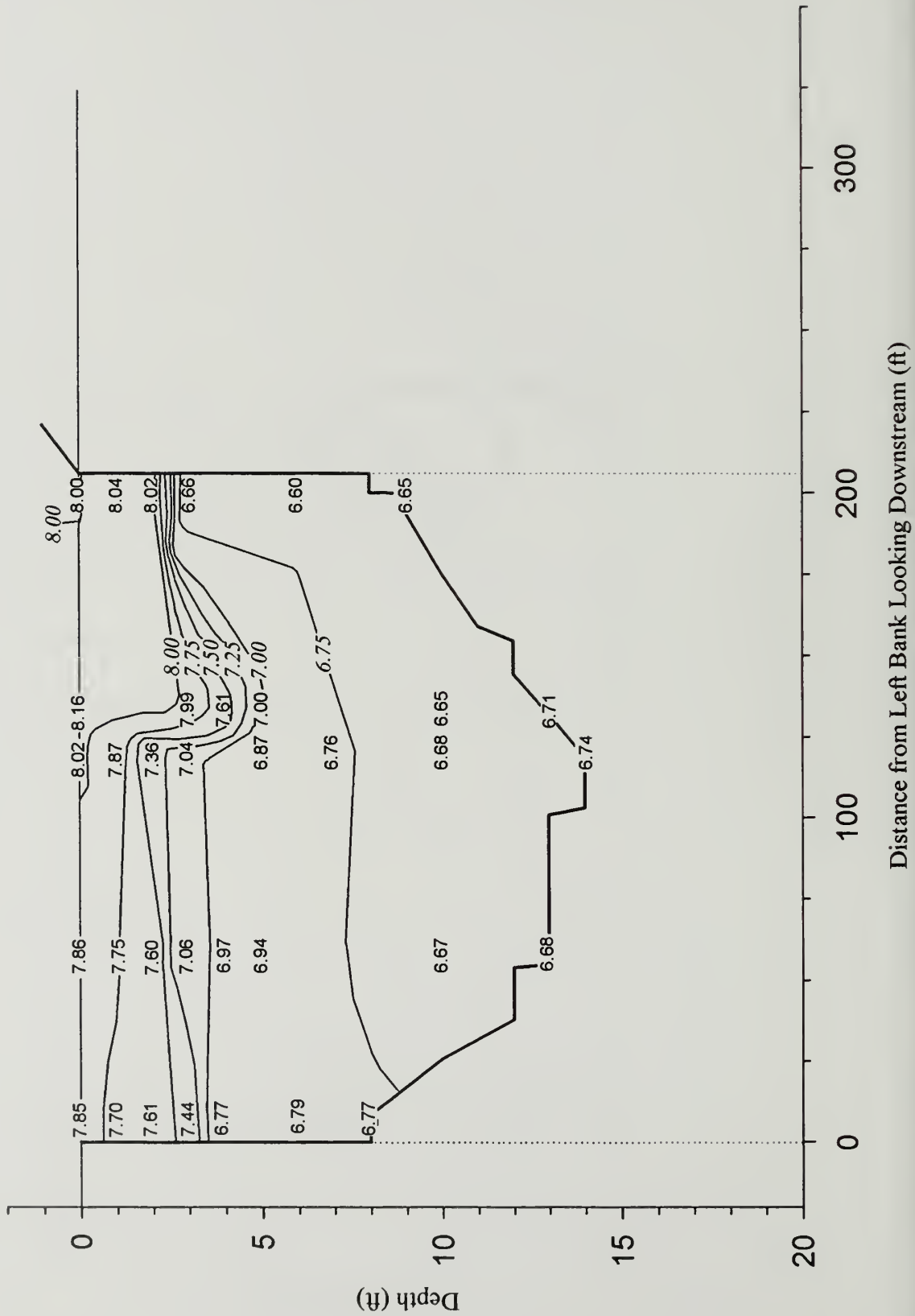

Station 14 (6/19/96): 104th Avenue,
 Cal-Sag Channel at RM 307.15
 (DO mg/L)

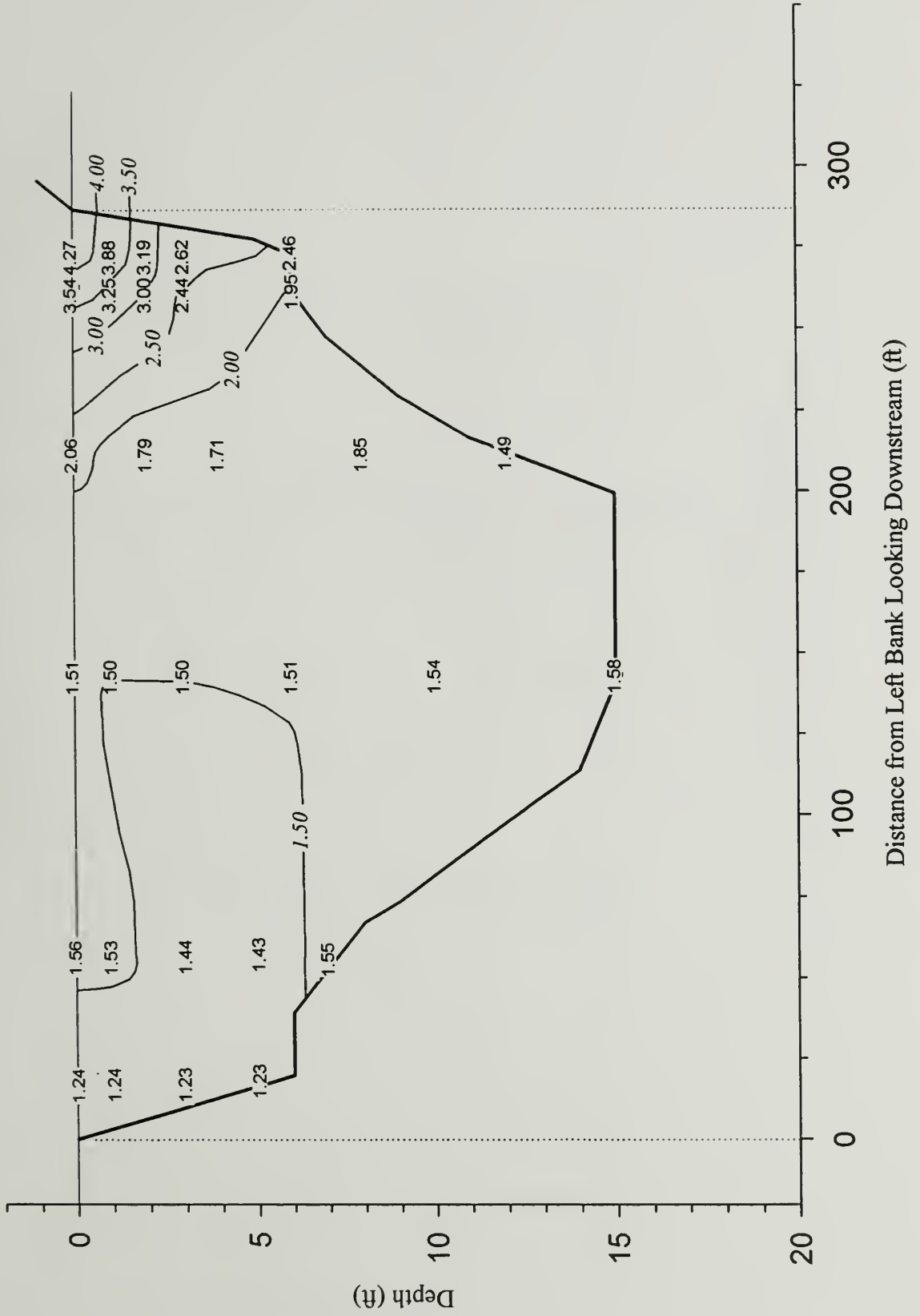

Station 15 (6/19/96): SEPA Station 5 Intake,
 Cal-Sag Channel at RM 303.63
 (DO mg/L)

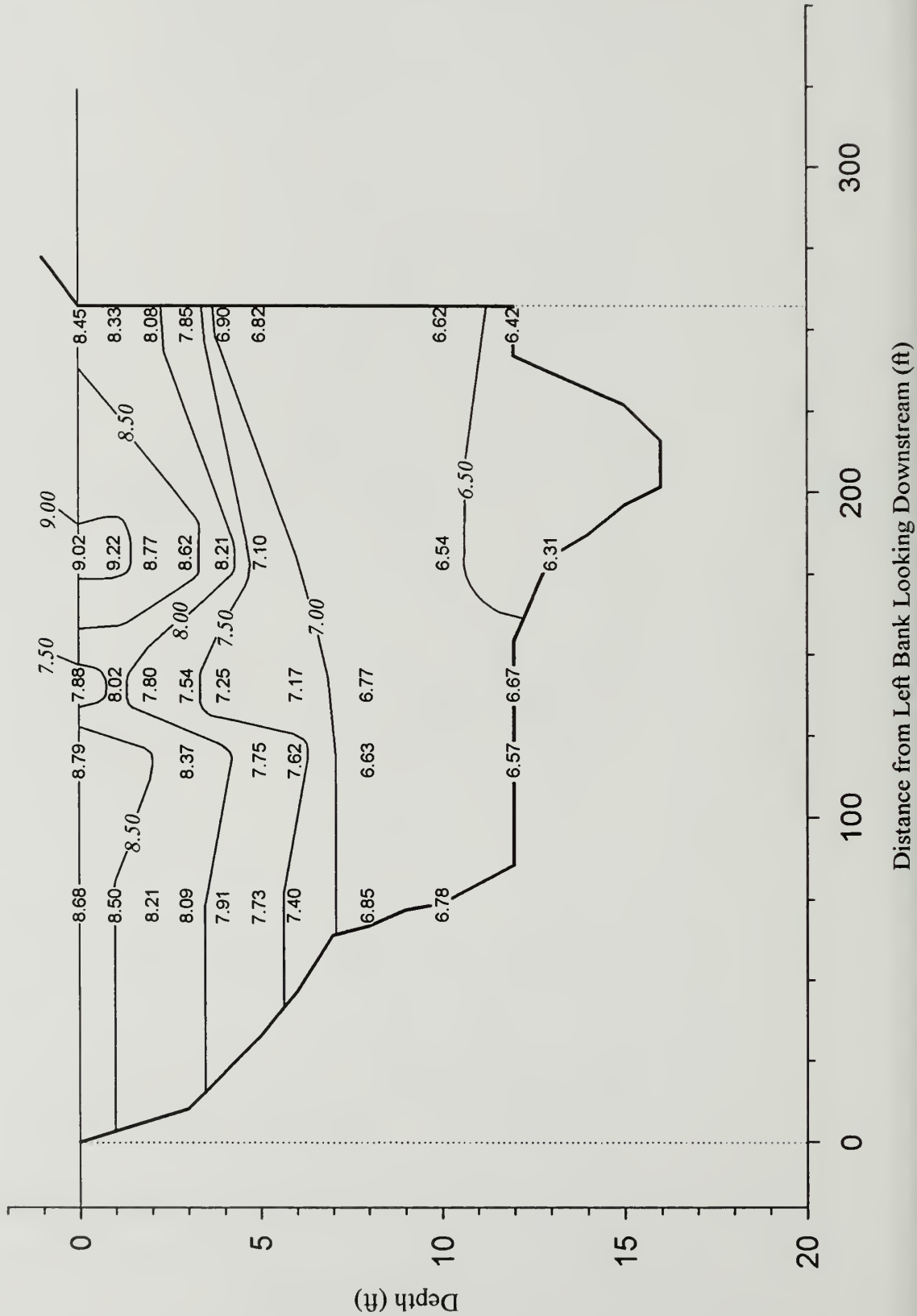

Appendix E
Hourly DO Probability Curves for Each Monitoring Station by Period

Station 1 (hourly): SEPA Station 1 Intake,
Calumet River at RM 328.10

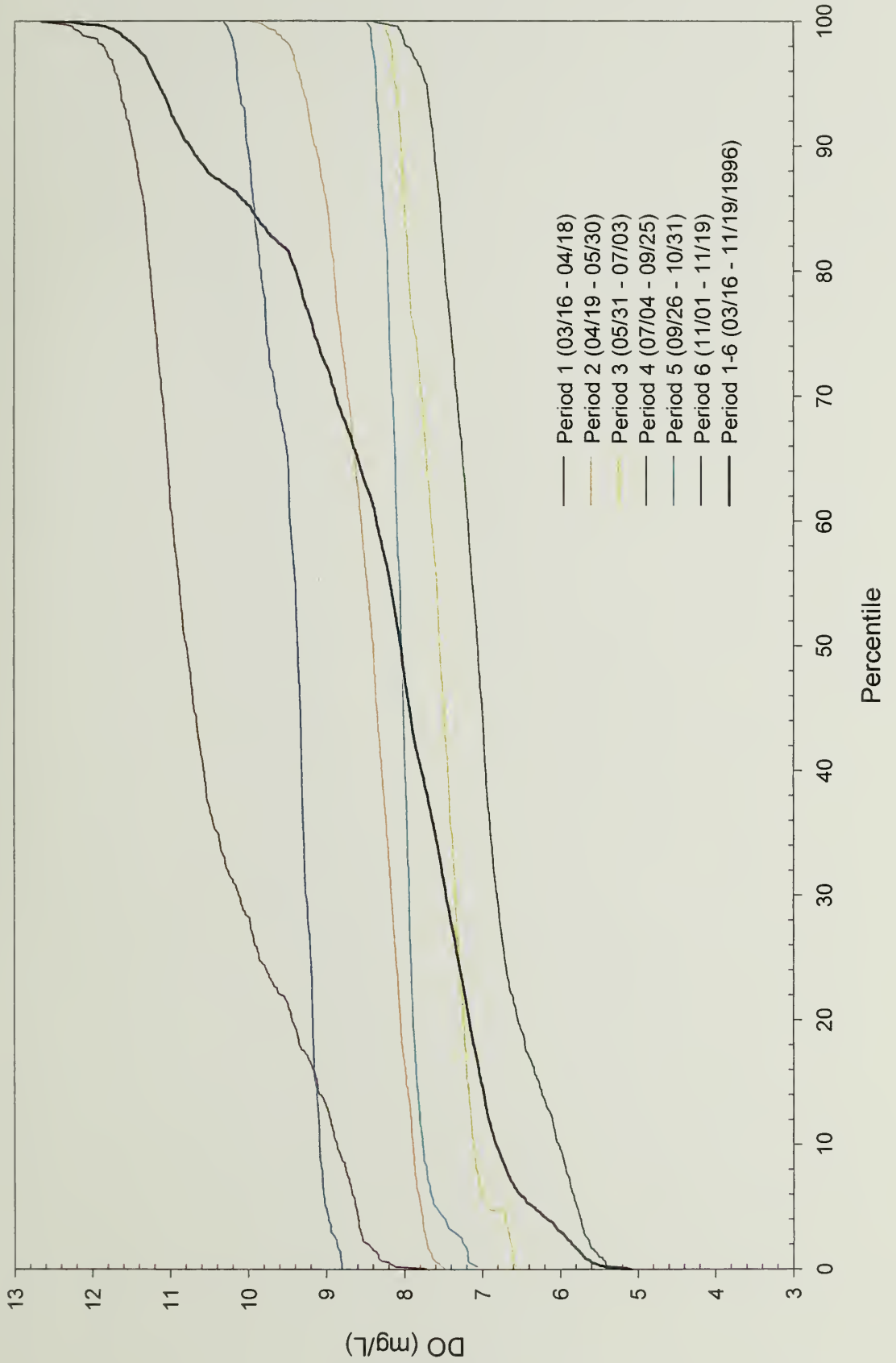

Station 2 (hourly): Norfolk/Western RR,
Calumet River at RM 327.69

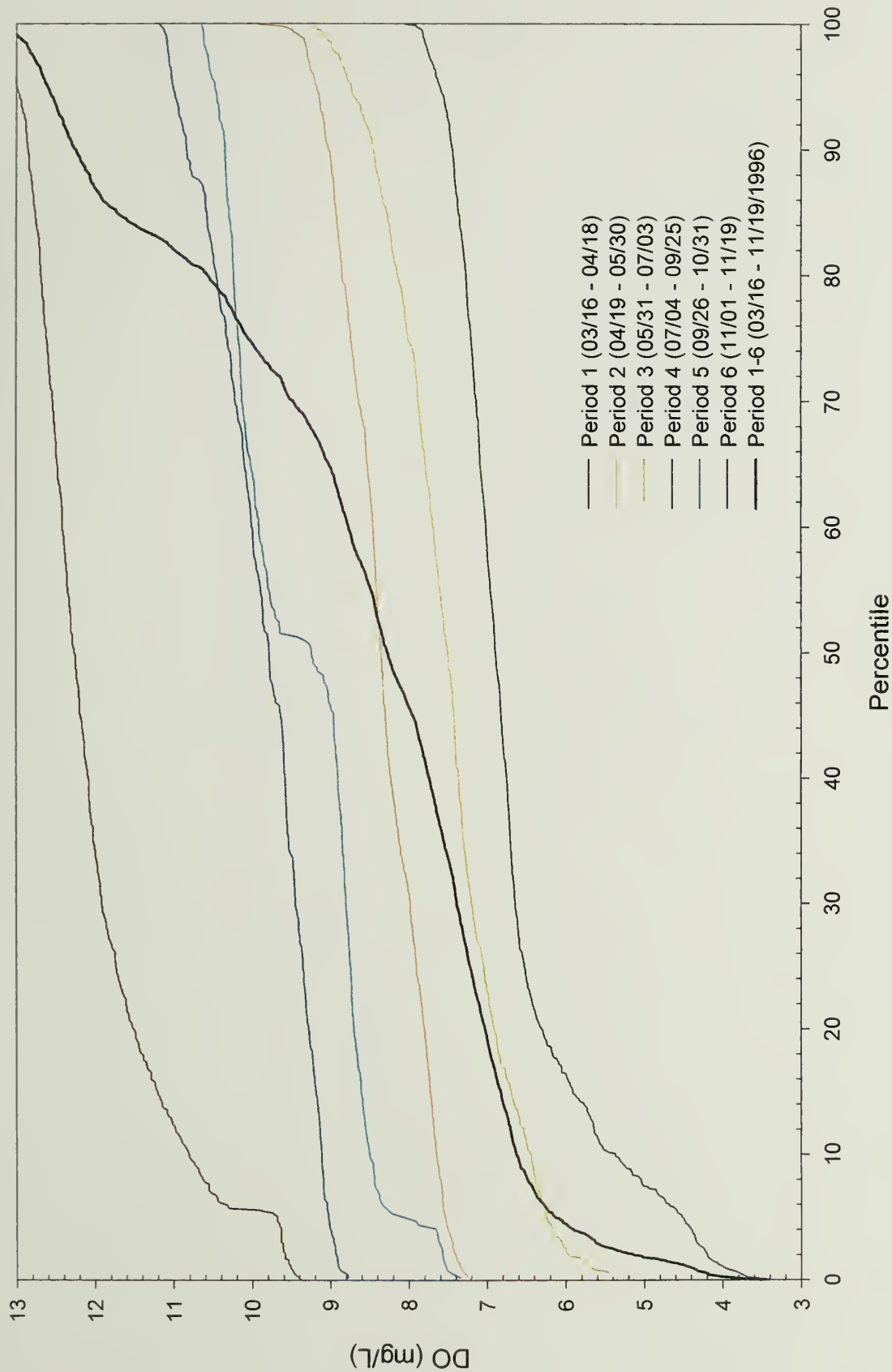

Station 6 (hourly): SEPA Station 2 Intake,
Little Calumet River at RM 321.32

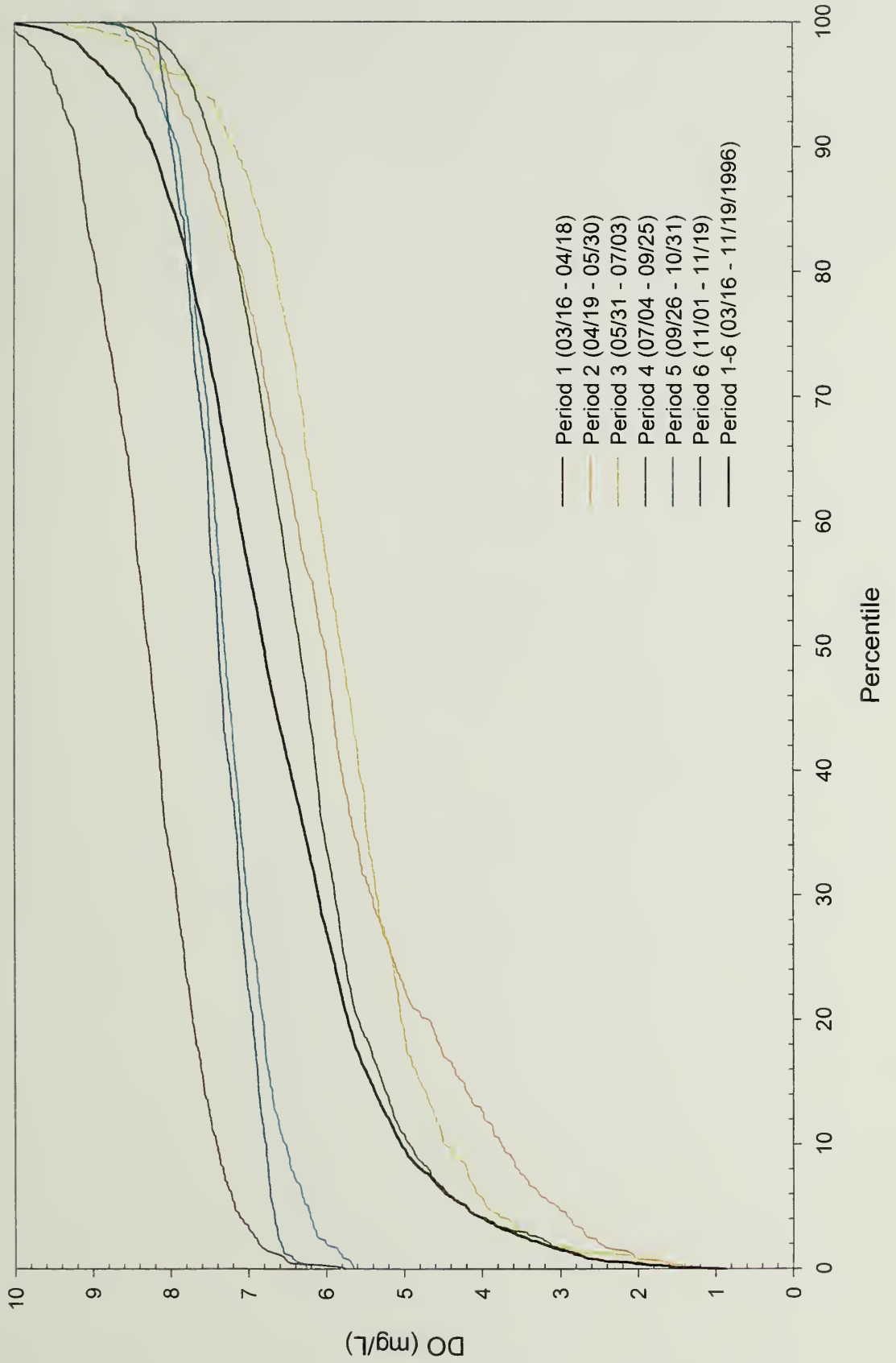

Station 7 (hourly): Penn Central RR,
Little Calumet River at RM 320.71



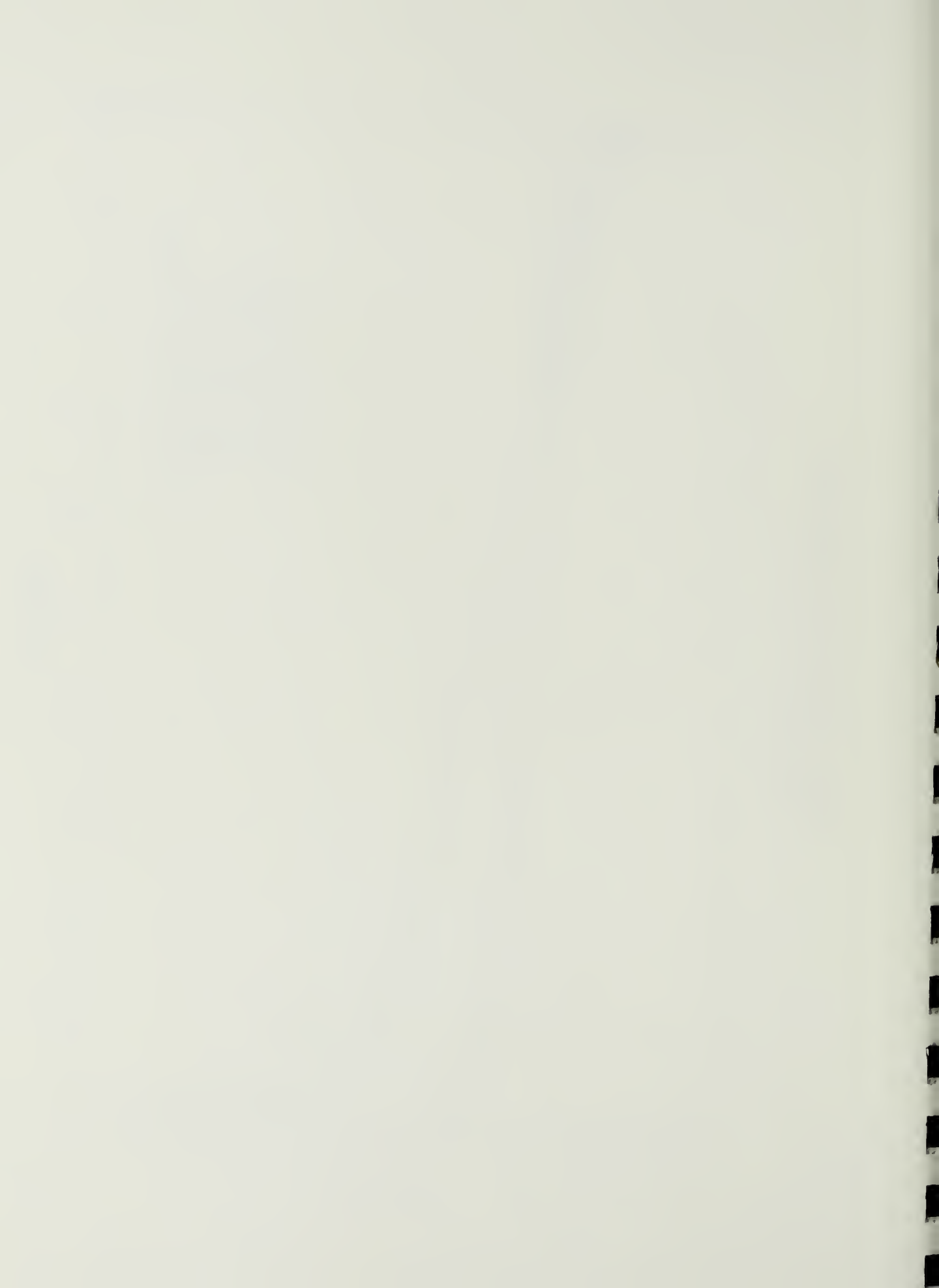

Station 9 (hourly): SEPA Station 3 Intake,
Cal-Sag Channel at RM 318.08

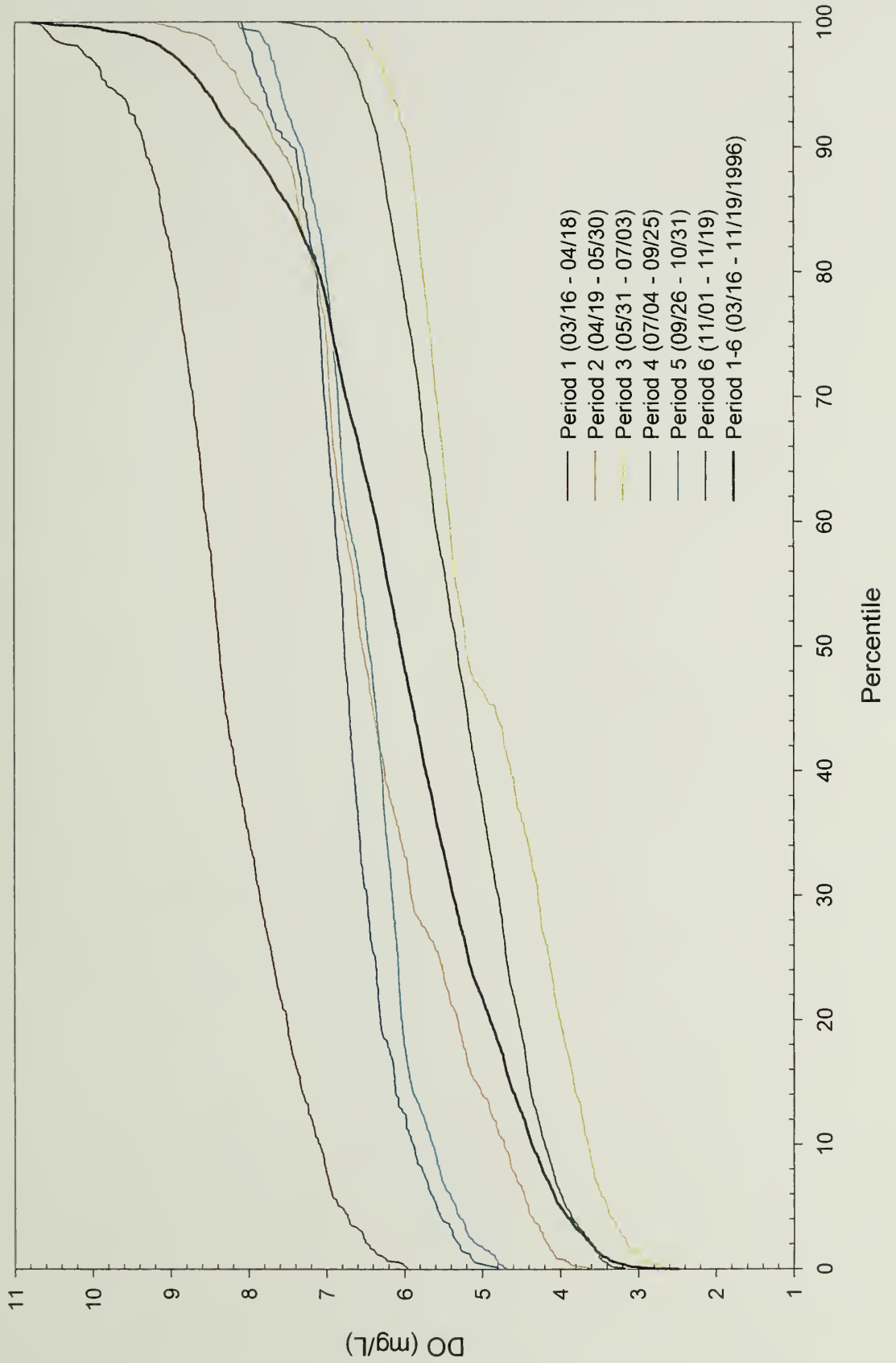

Station 10 (hourly): Baltimore/Ohio RR,
Cal-Sag Channel at RM 317.62

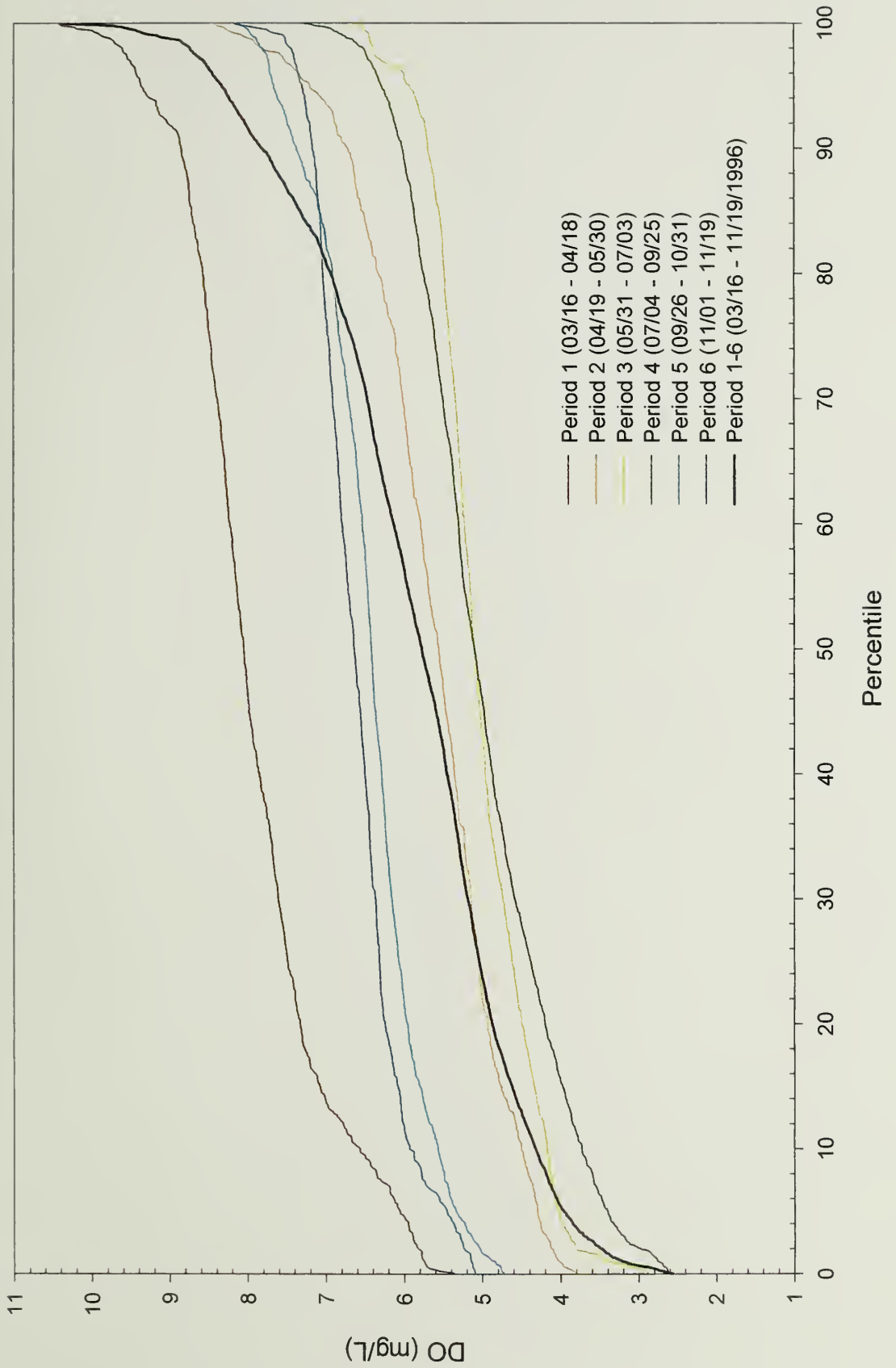

Station 12 (hourly): SEPA Station 4 Intake,
Cal-Sag Channel at RM 311.55

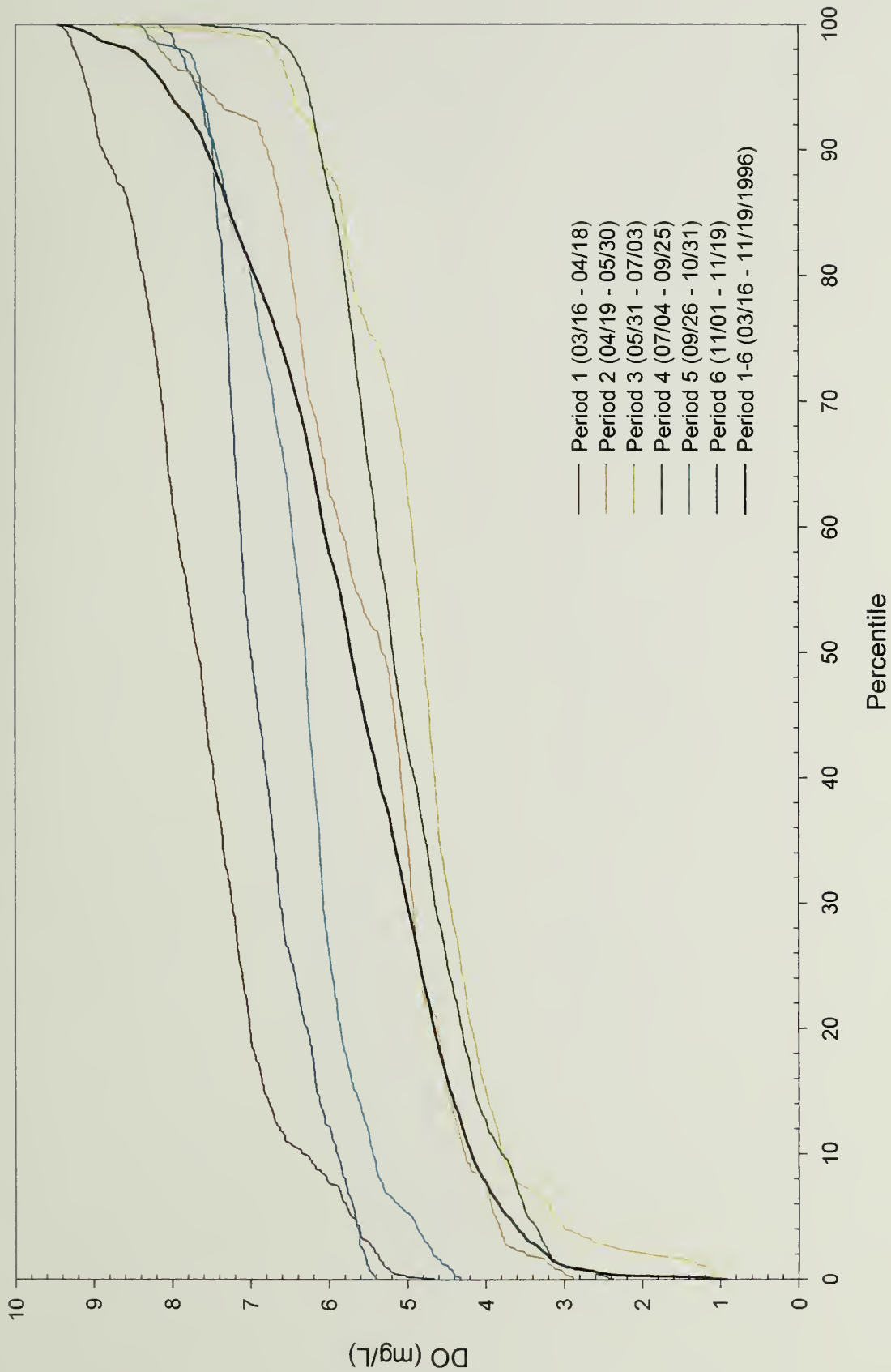

Station 13 (hourly): Southwest Hwy,
Cal-Sag Channel at RM 310.70

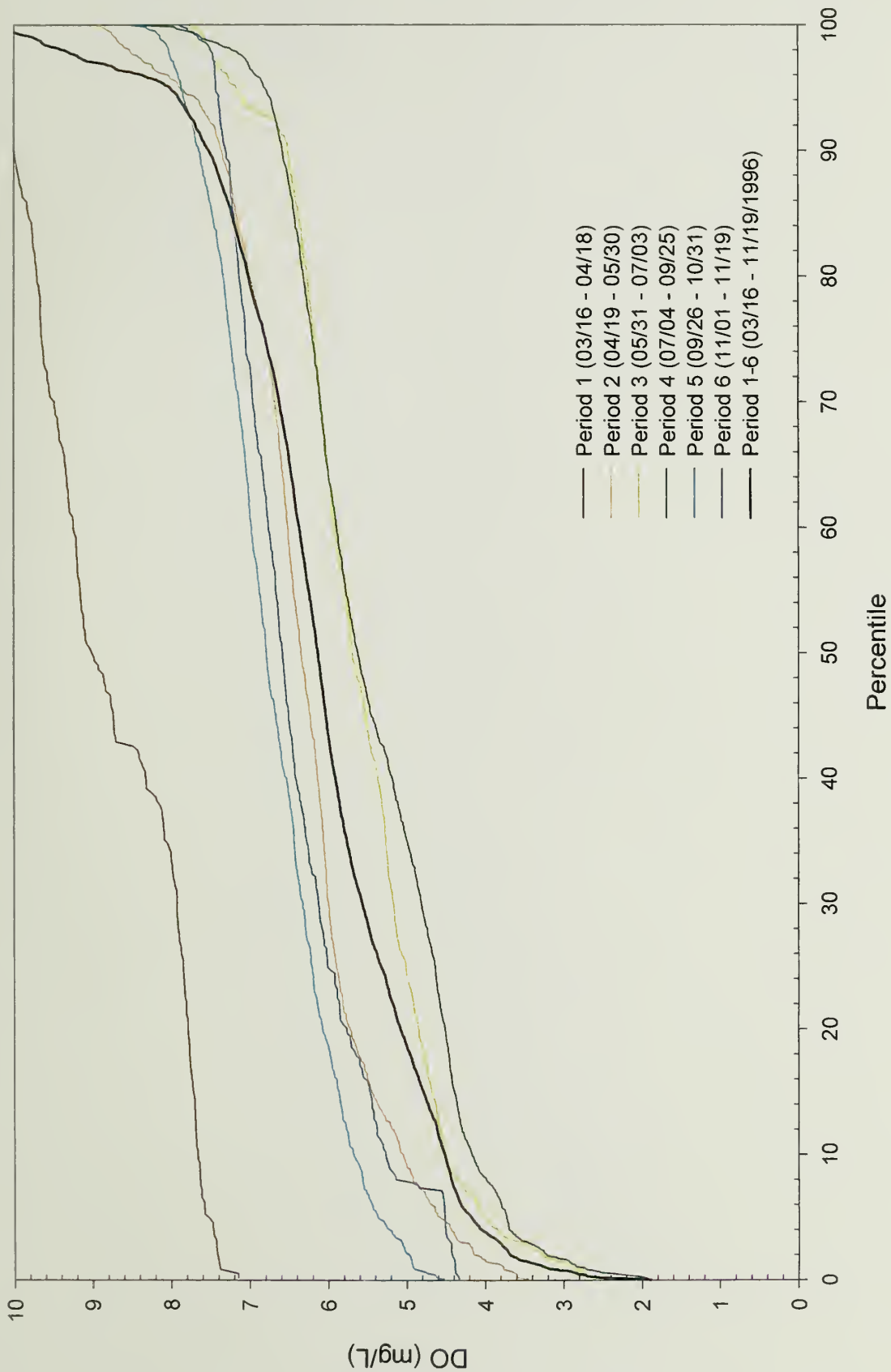

Station 14 (hourly): 104th Avenue,
Cal-Sag Channel at RM 307.15

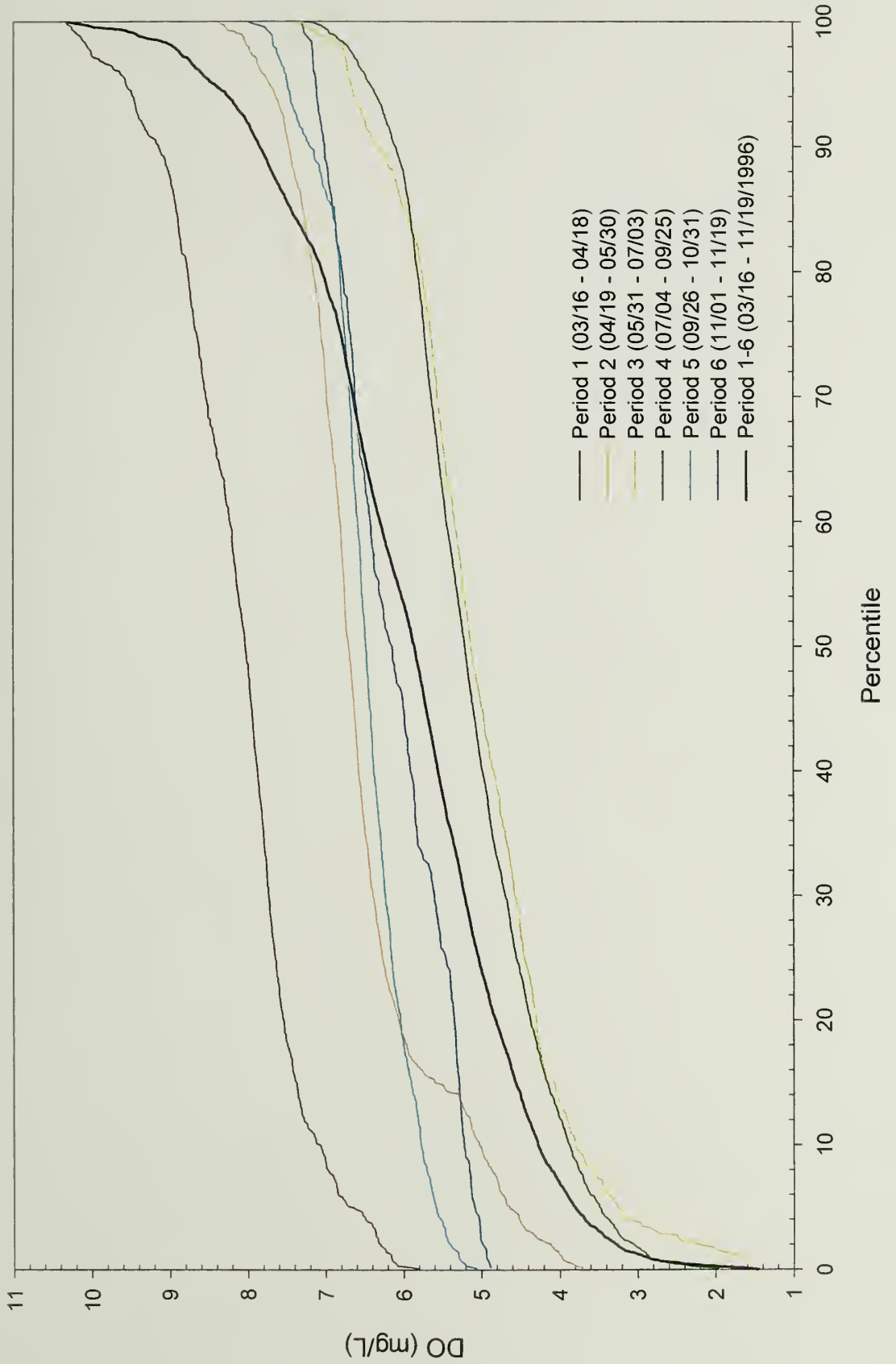

Station 15 (hourly): SEPA Station 5 Intake,
Cal-Sag Channel at RM 303.63

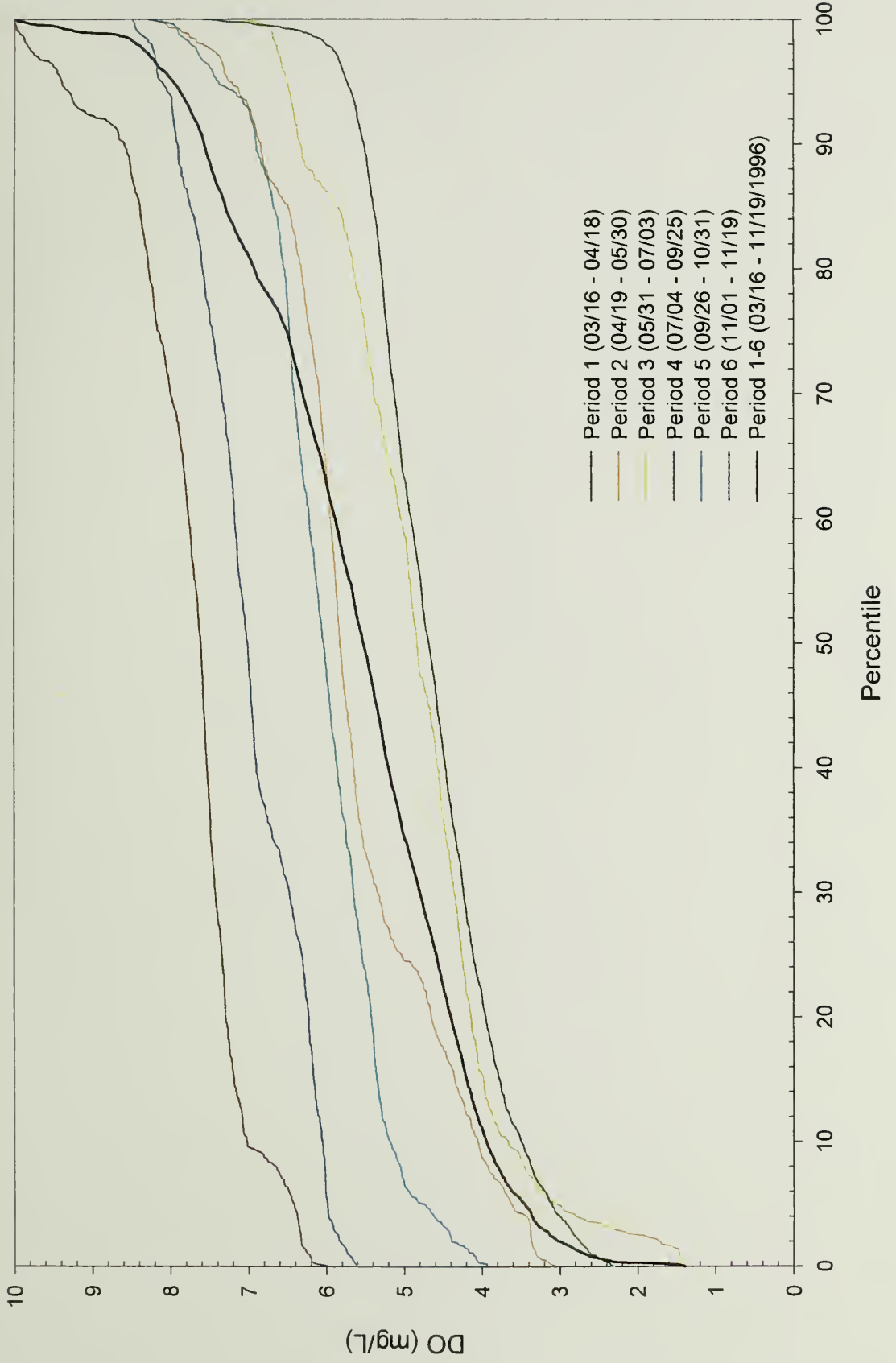

Station 16 (hourly): Hwy 83,
Chicago Sanitary and Ship Canal at RM 304.69

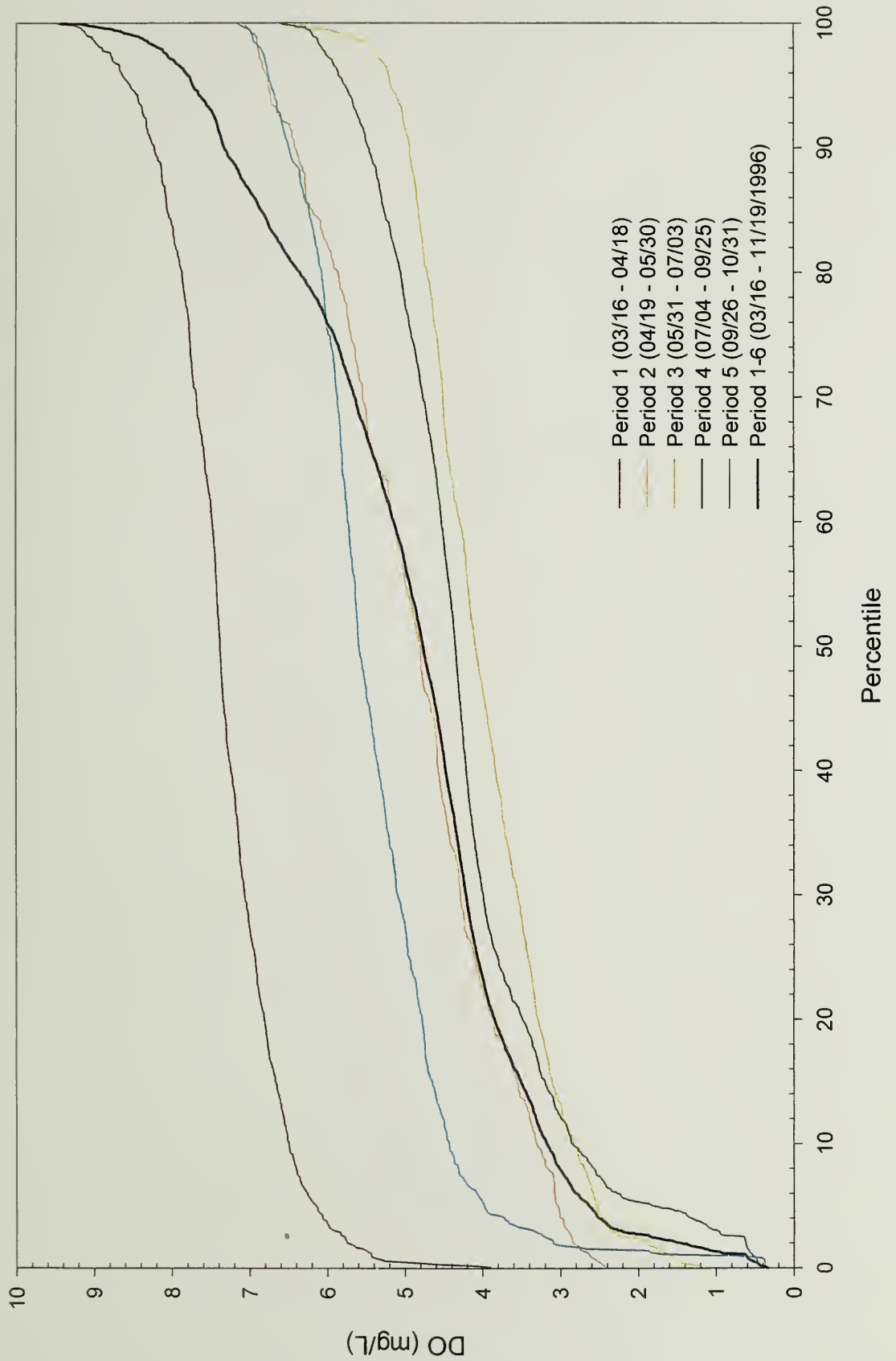

Station 17 (hourly): Power Lines,
Chicago Sanitary and Ship Canal at RM 302.36

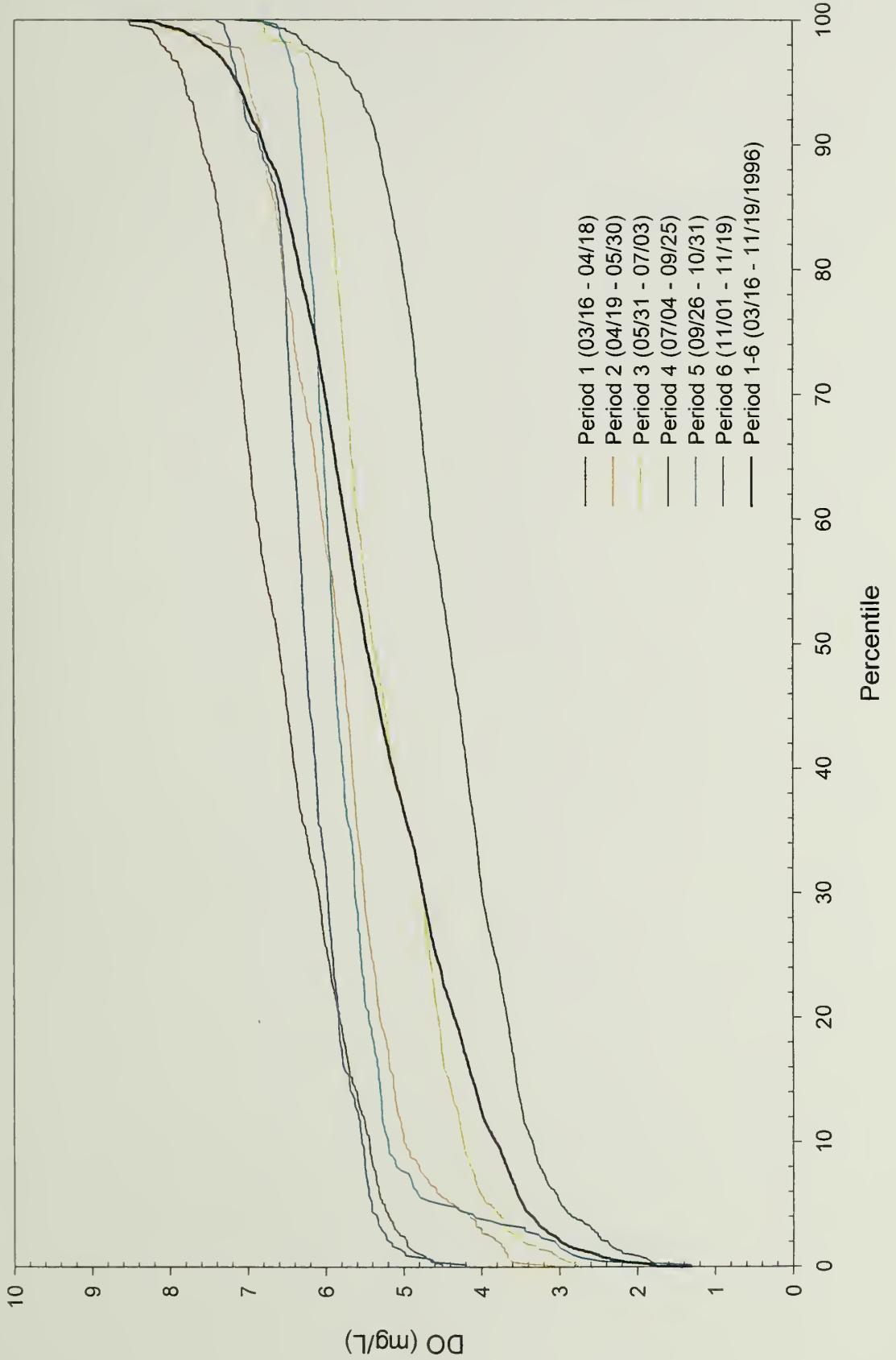

Station 18 (hourly): Slip No. 2,
Chicago Sanitary and Ship Canal at RM 299.55

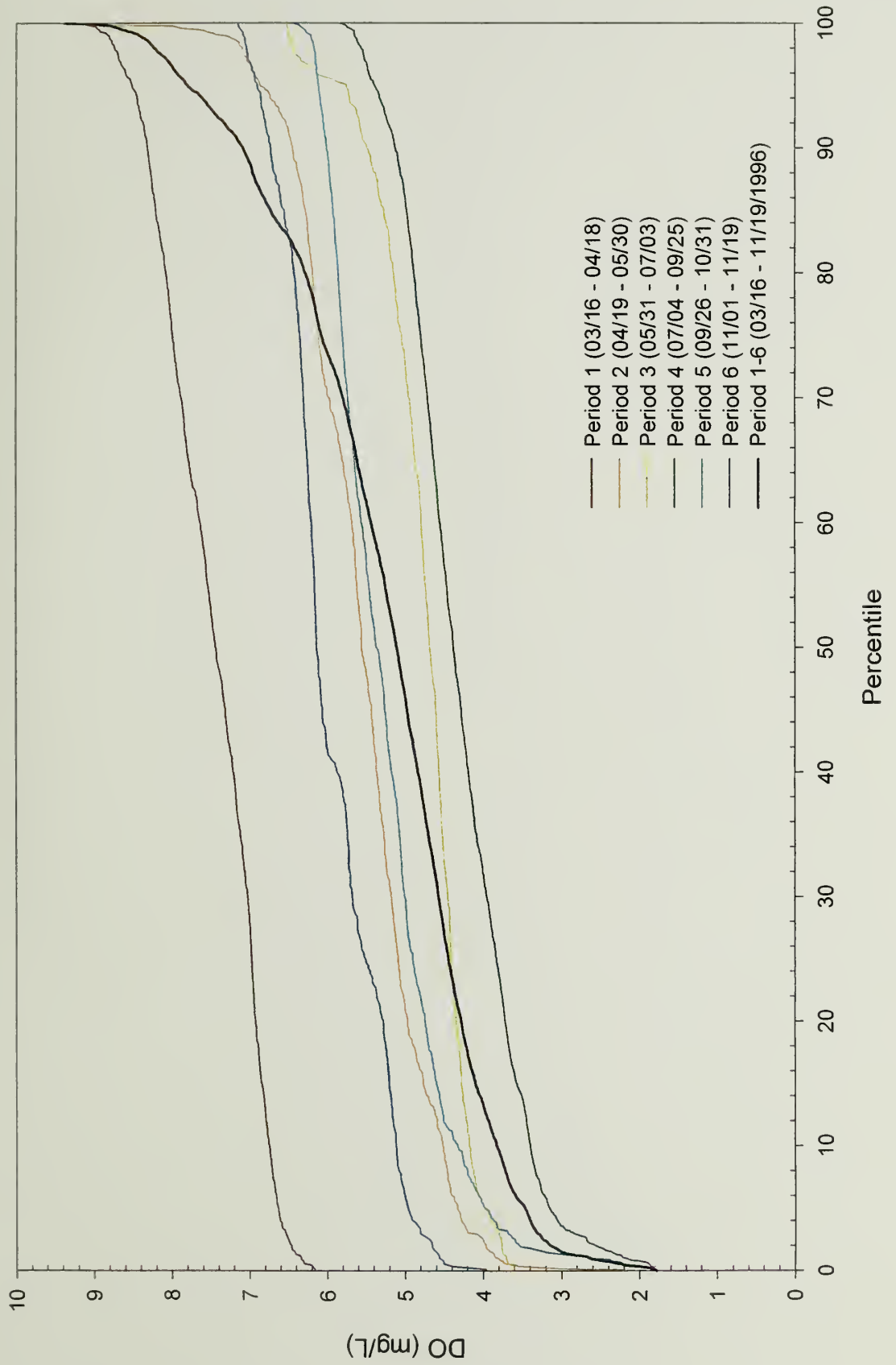

Station 21t (hourly): Lockport Lock and Dam,
Chicago Sanitary and Ship Canal at RM 291.20

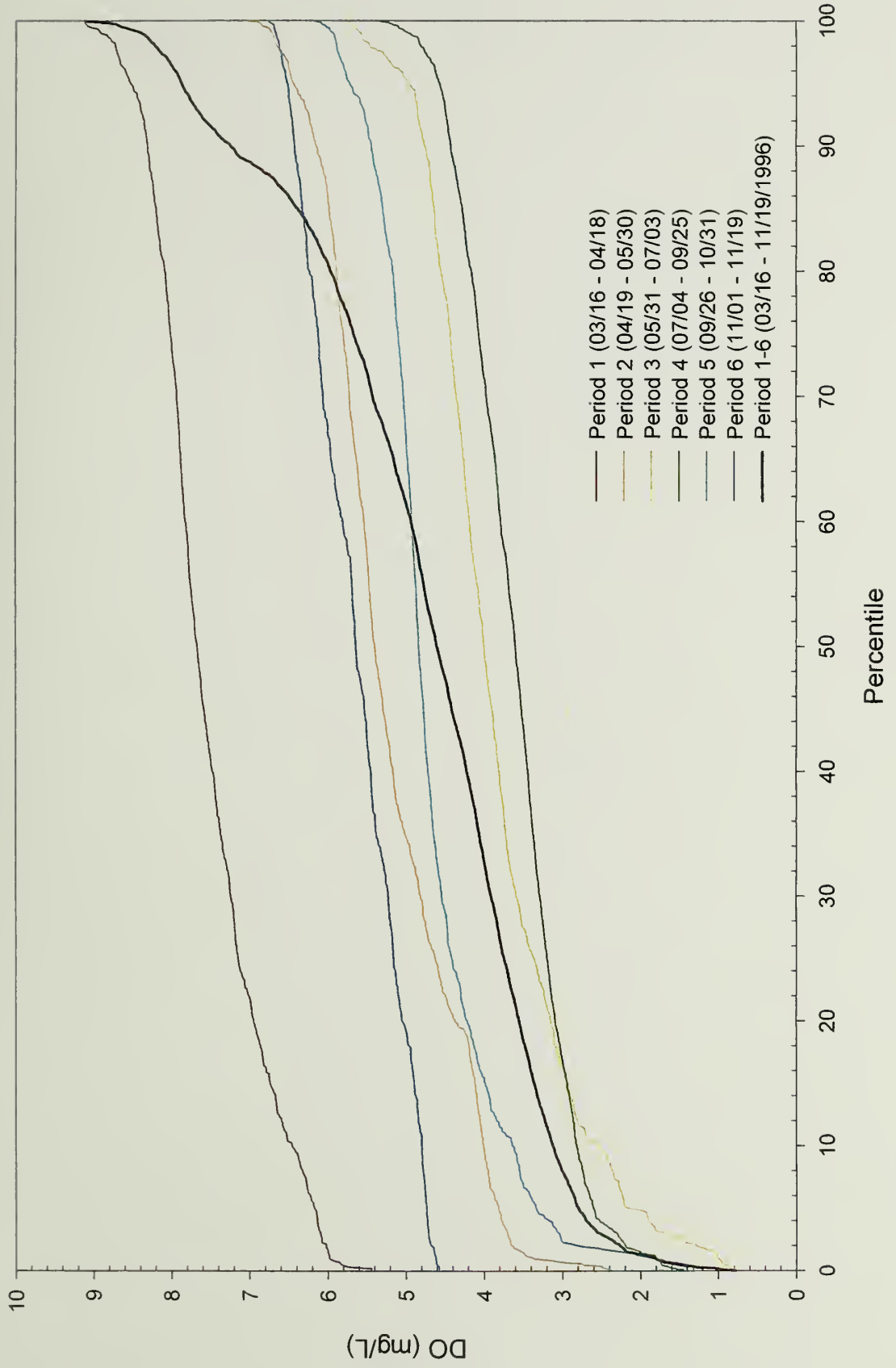

Station 21m (hourly): Lockport Lock and Dam,
Chicago Sanitary and Ship Canal at RM 291.20

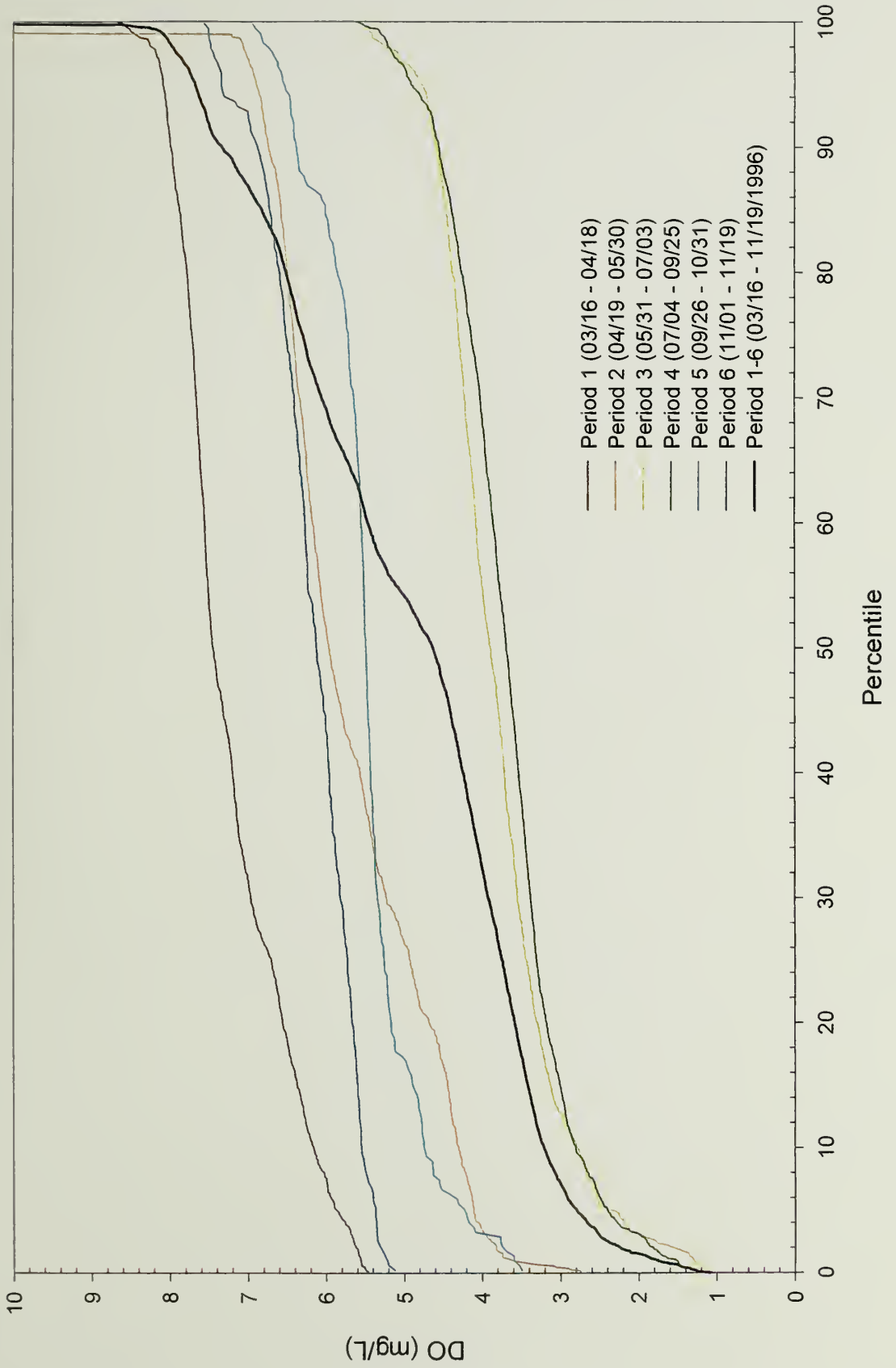

Station 21b (hourly): Lockport Lock and Dam,
Chicago Sanitary and Ship Canal at RM 291.20

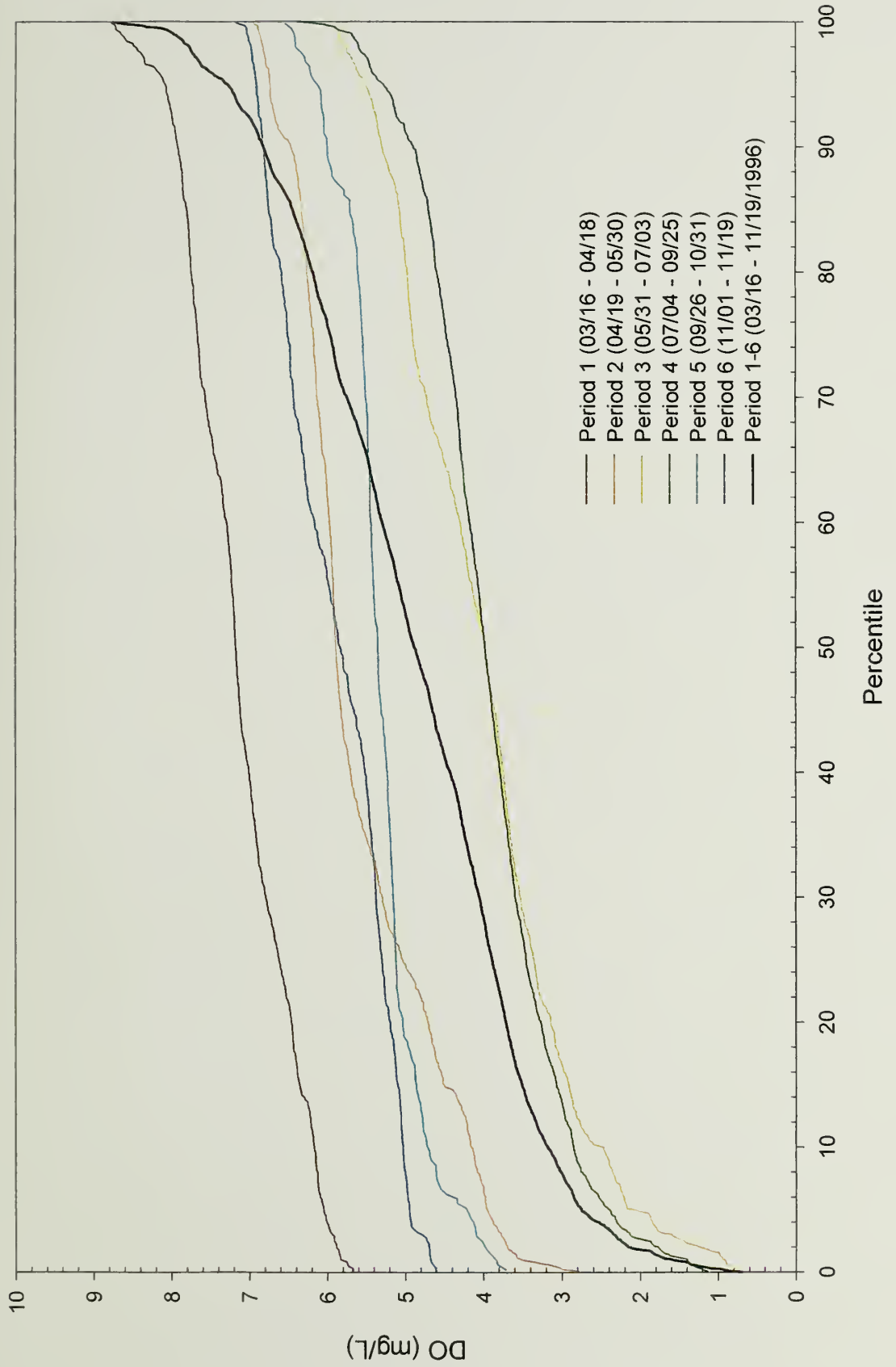

Appendix F

Daily Mean Probability Curves for Each Monitoring Station by Period

Station 1 (daily): SEPA Station 1 Intake,
Calumet River at RM 328.10

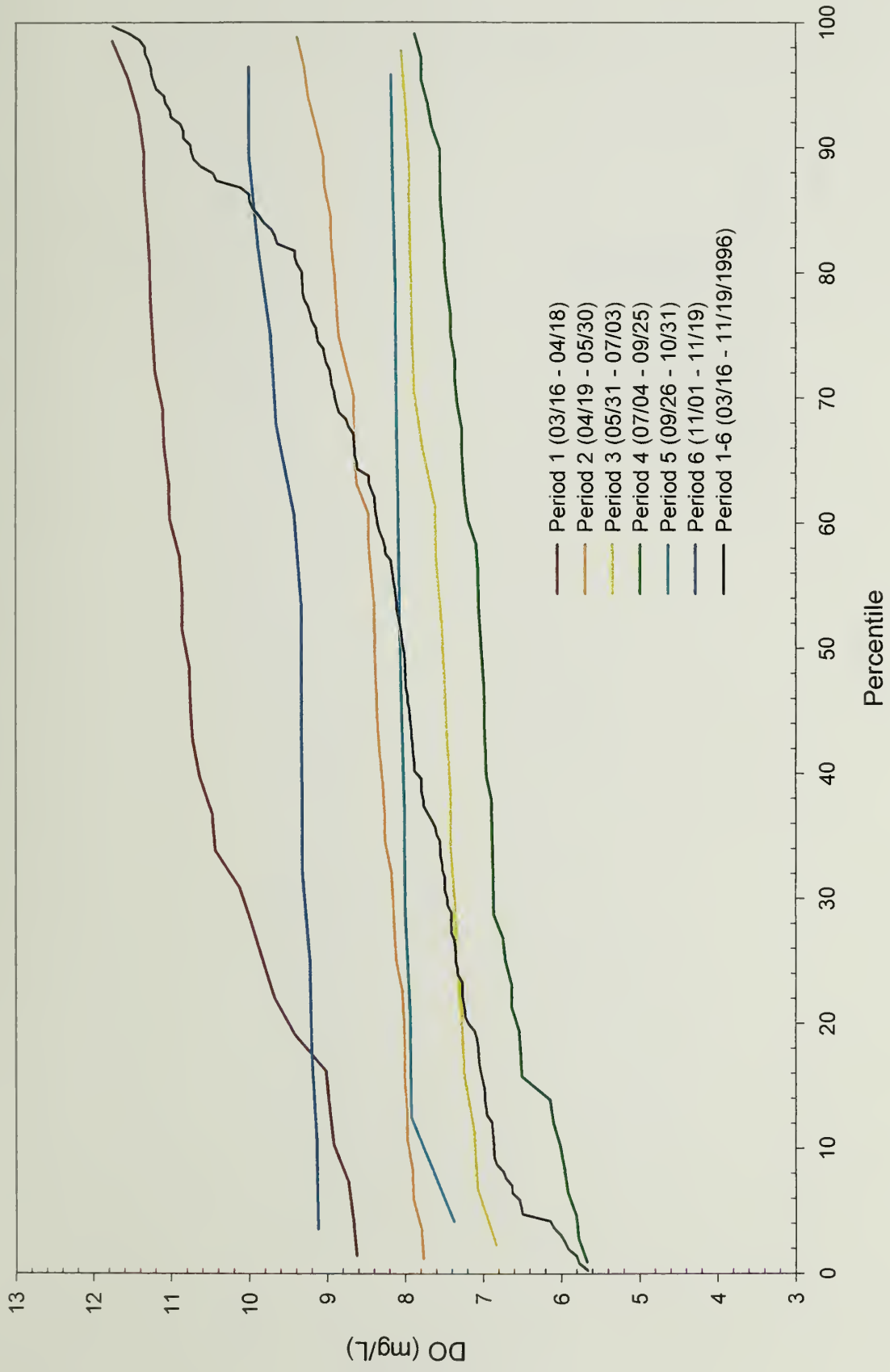

Station 2 (daily): Norfolk/Western RR,
Calumet River at RM 327.69

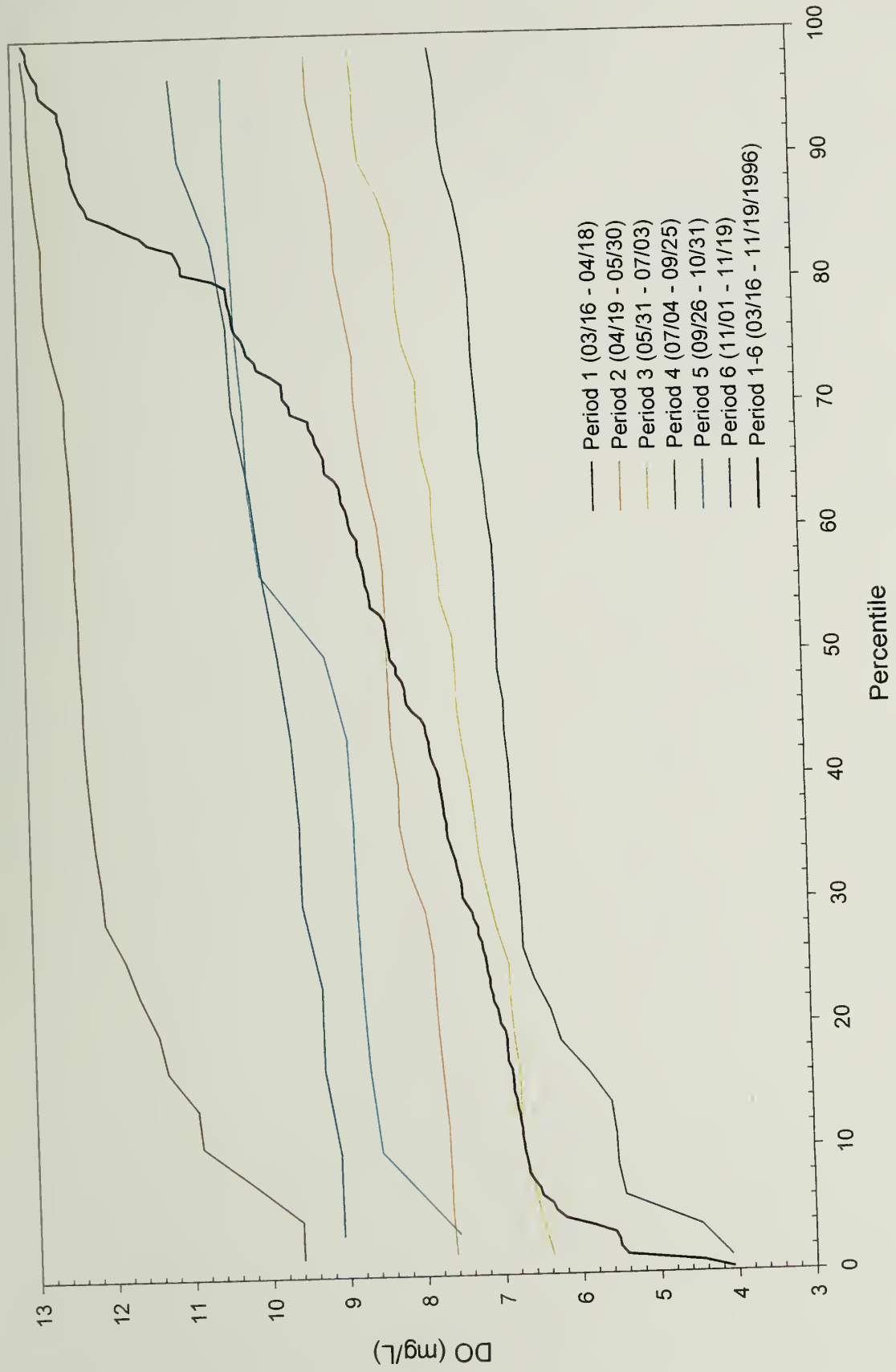

Station 6 (daily): SEPA Station 2 Intake.
Little Calumet River at RM 321.32

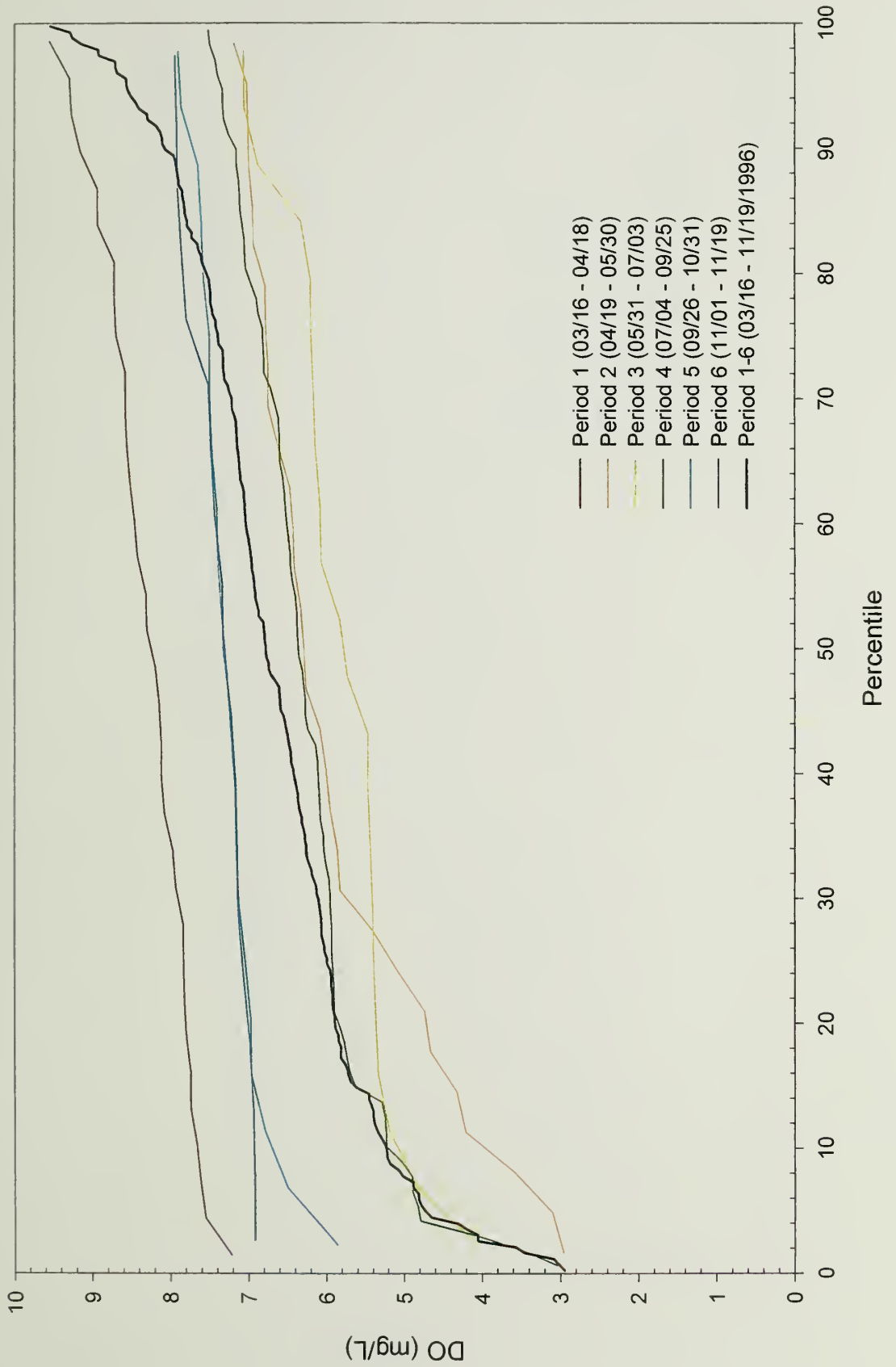

Station 7 (daily): Penn Central RR,
Little Calumet River at RM 320.71



Station 9 (daily): SEPA Station 3 Intake,
Cal-Sag Channel at RM 318.08

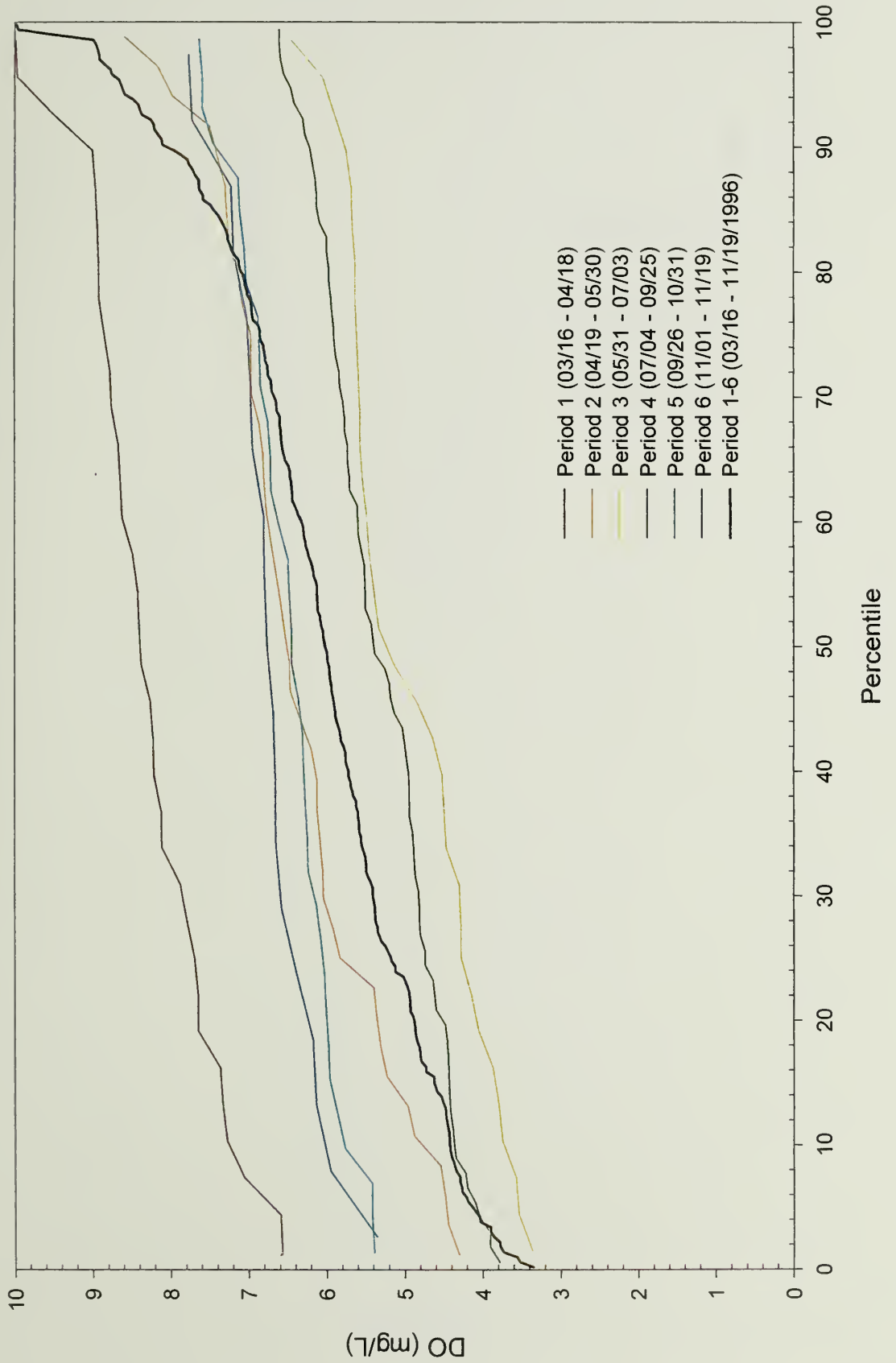

Station 10 (daily): Baltimore/Ohio RR,
Cal-Sag Channel at RM 317.62

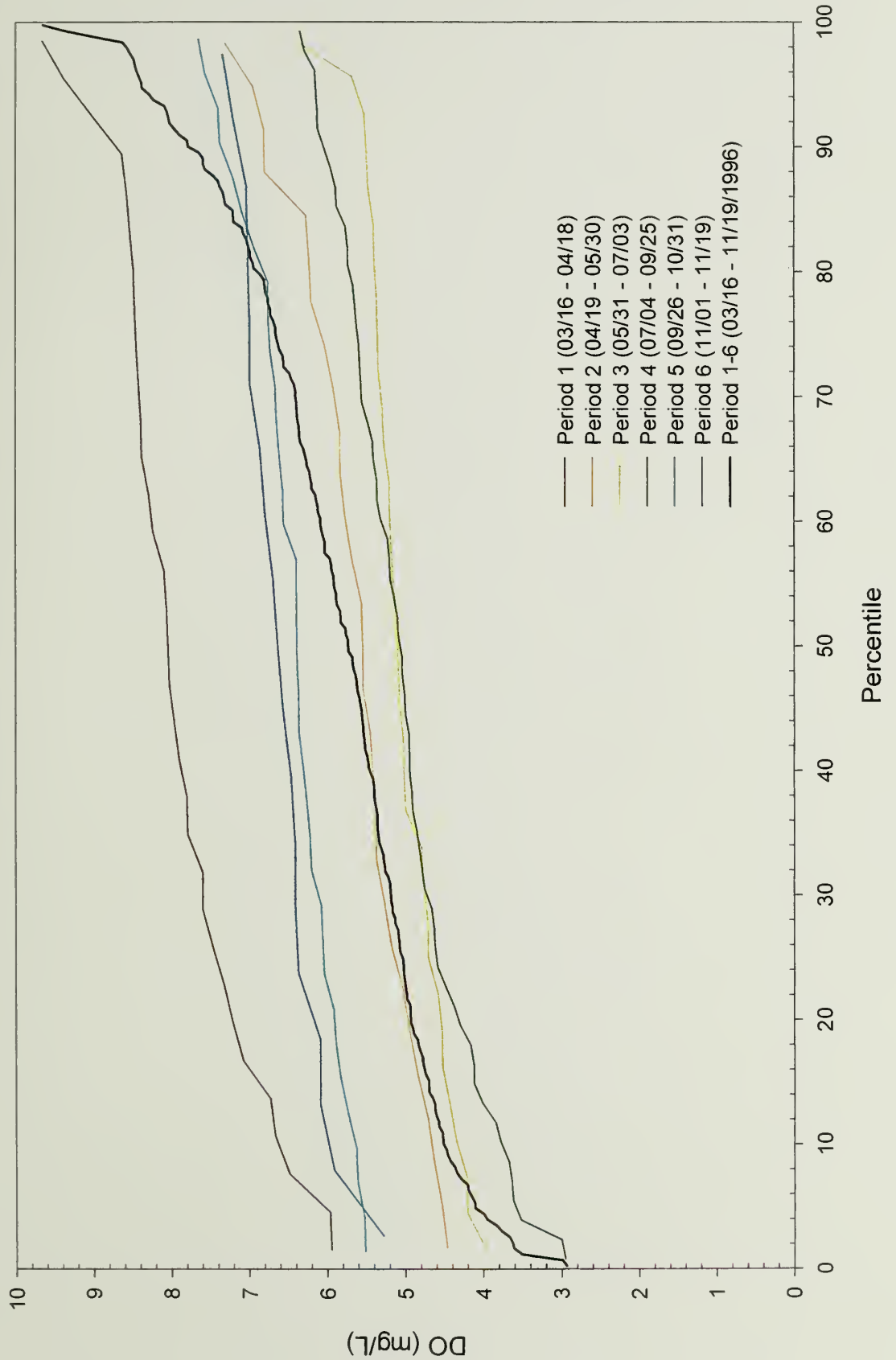

Station 12 (daily): SEPA Station 4 Intake,
Cal-Sag Channel at RM 311.55

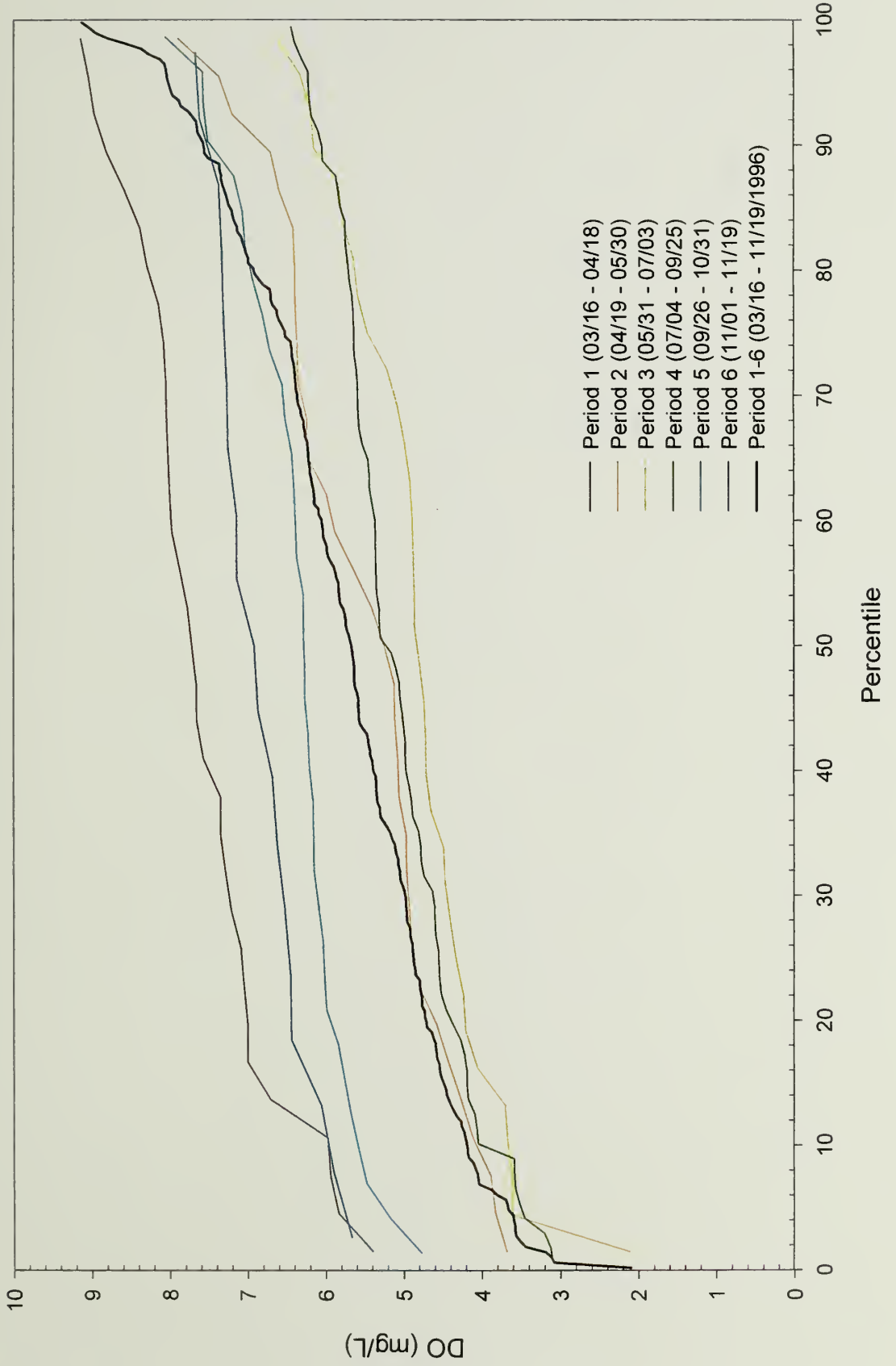

Station 13 (daily): Southwest Hwy,
Cal-Sag Channel at RM 310.70



Station 14 (daily): 104th Avenue,
Cal-Sag Channel at RM 307.15

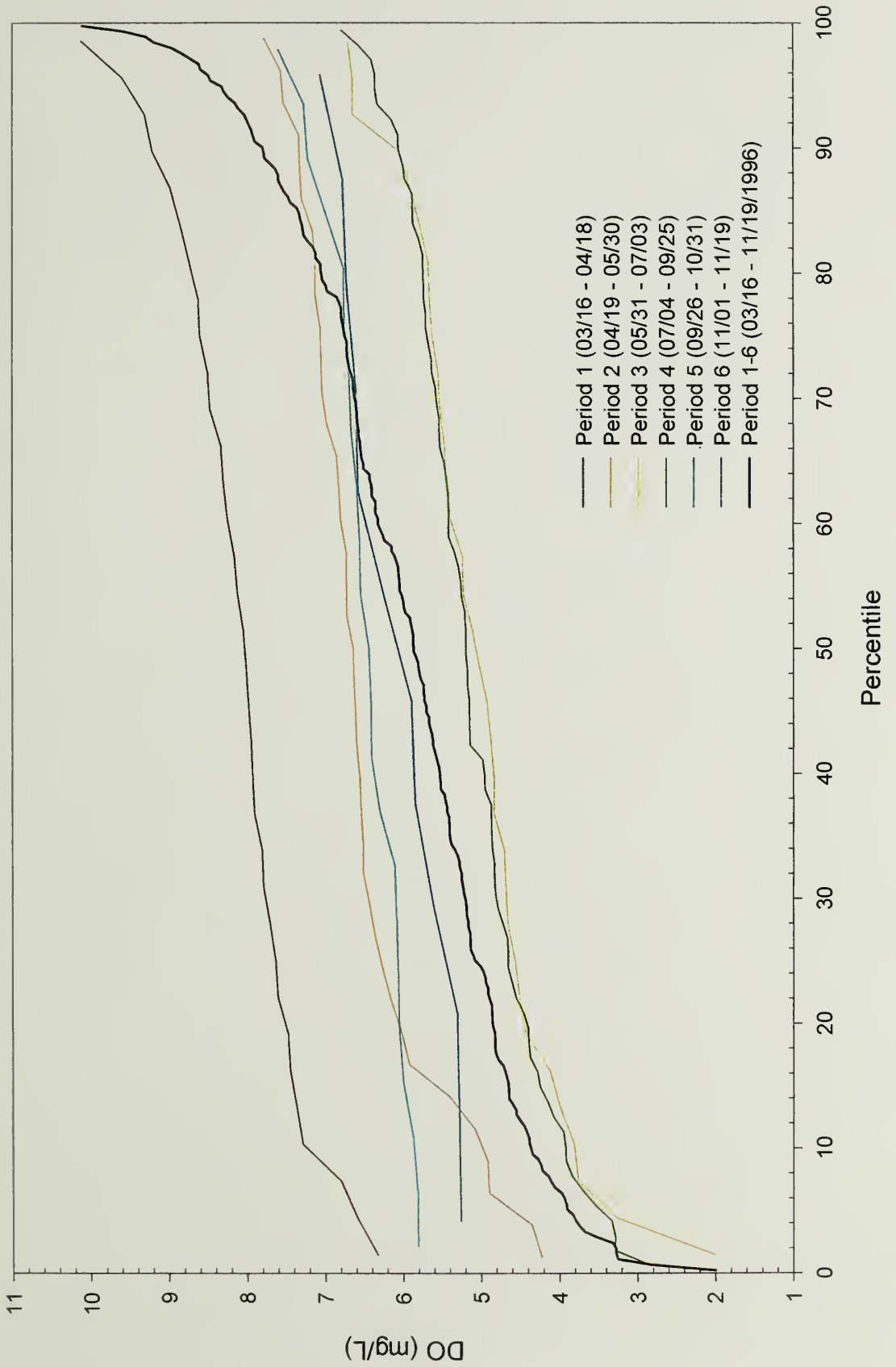

Station 15 (daily): SEPA Station 5 Intake,
Cal-Sag Channel at RM 303.63

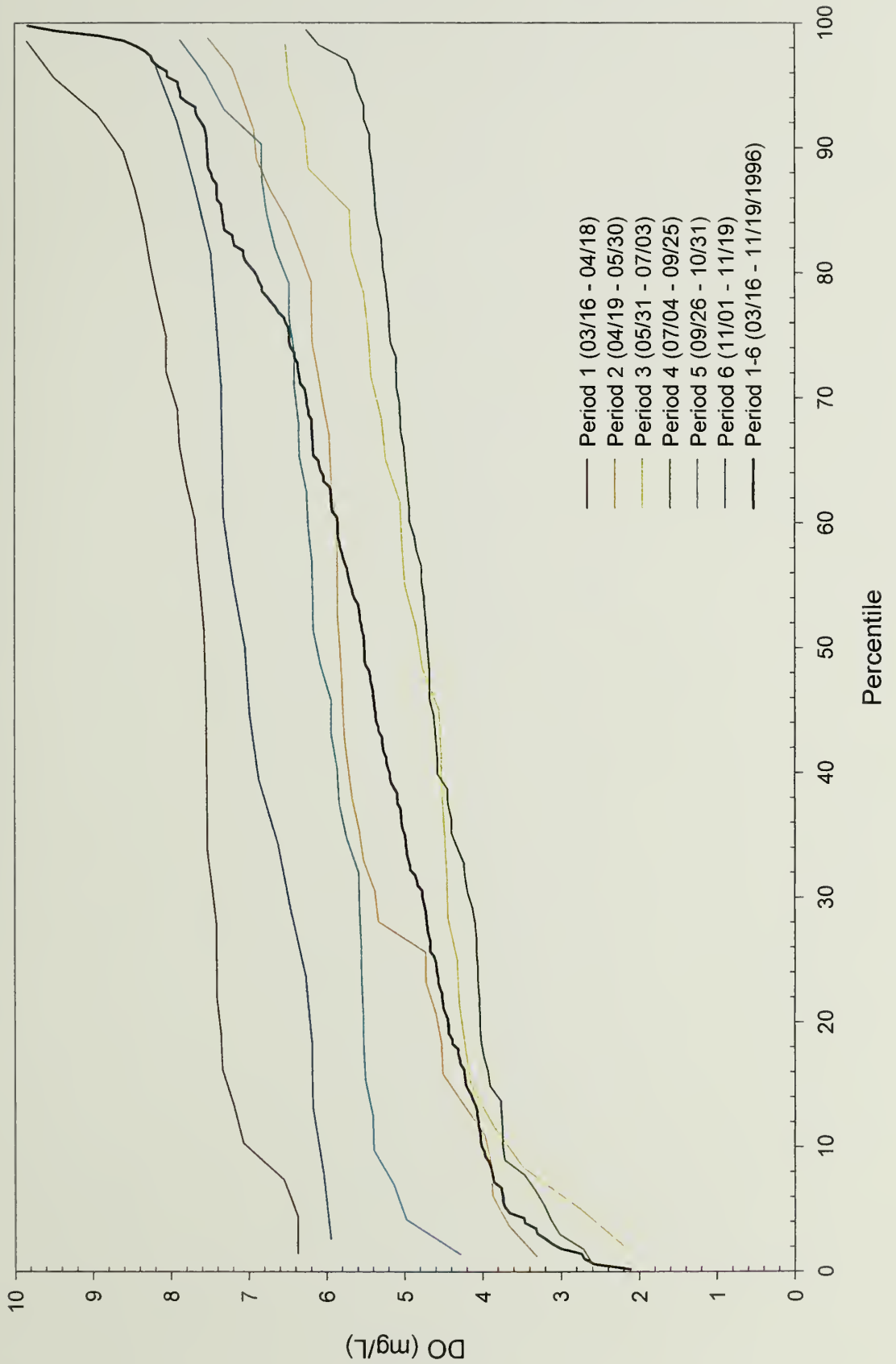

Station 16 (daily): Hwy 83,
Chicago Sanitary and Ship Canal at RM 304.69

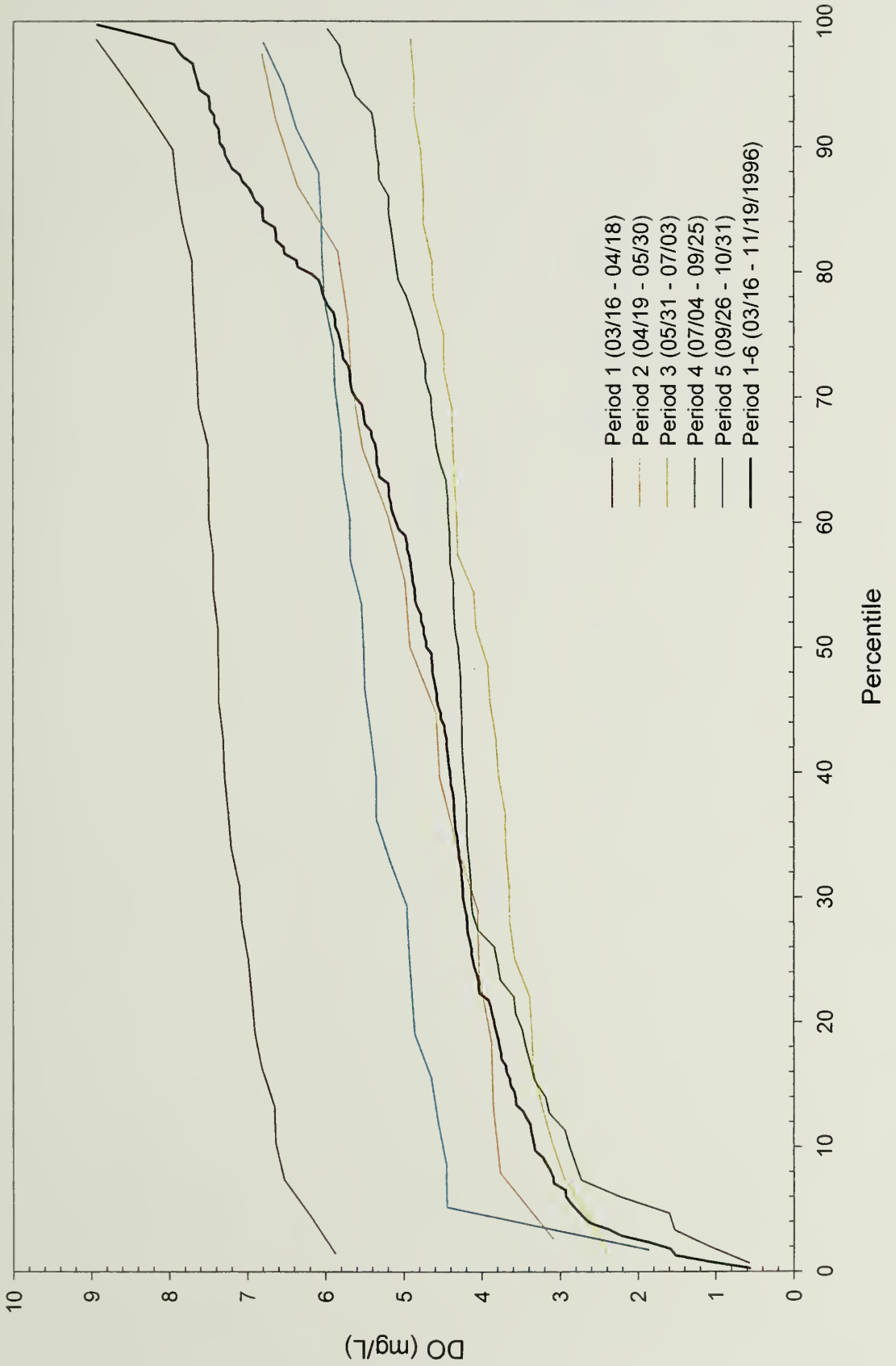

Station 17 (daily): Power Lines,
Chicago Sanitary and Ship Canal at RM 302.36

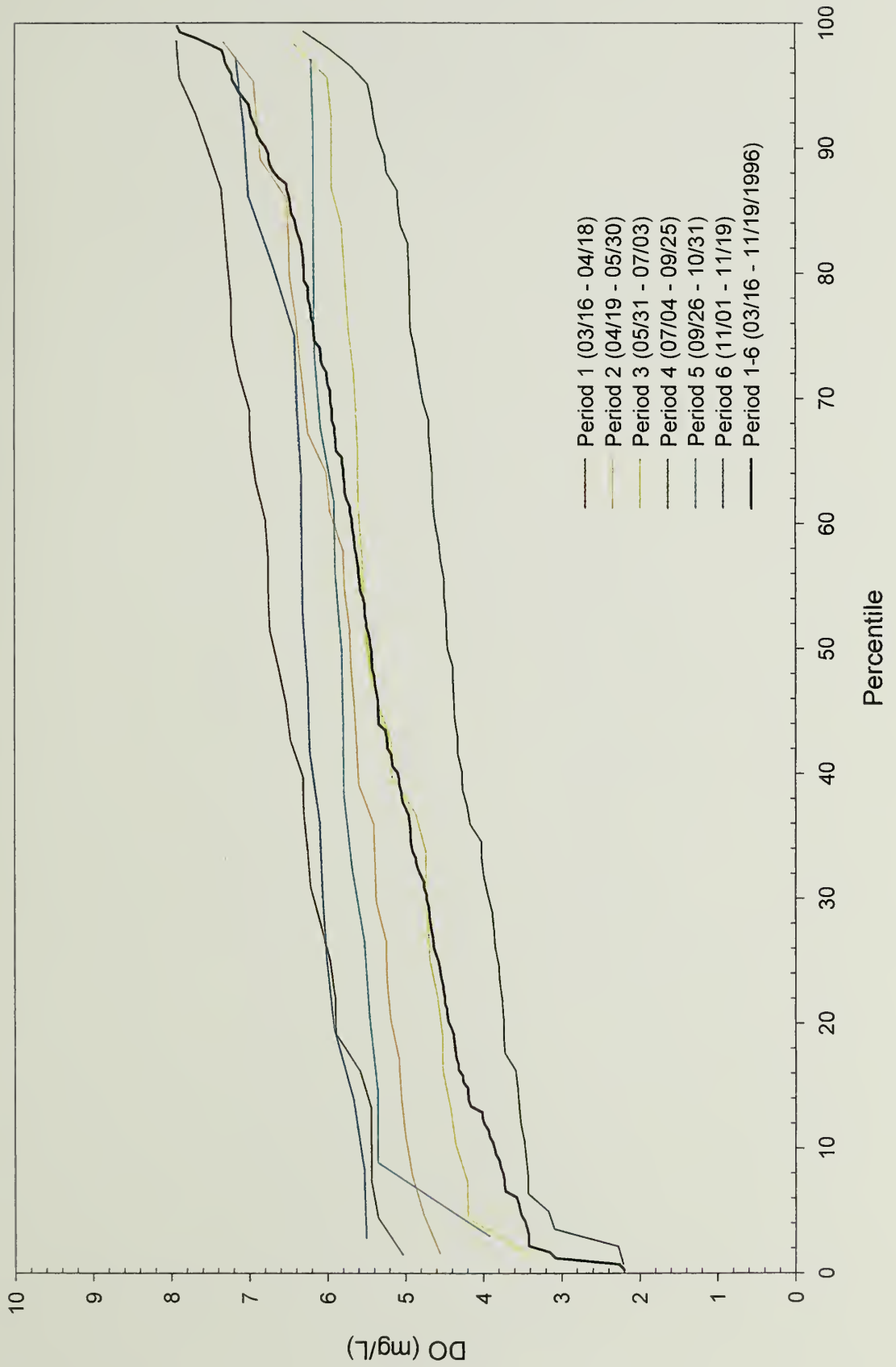

Station 18 (daily): Slip No. 2,
Chicago Sanitary and Ship Canal at RM 299.55

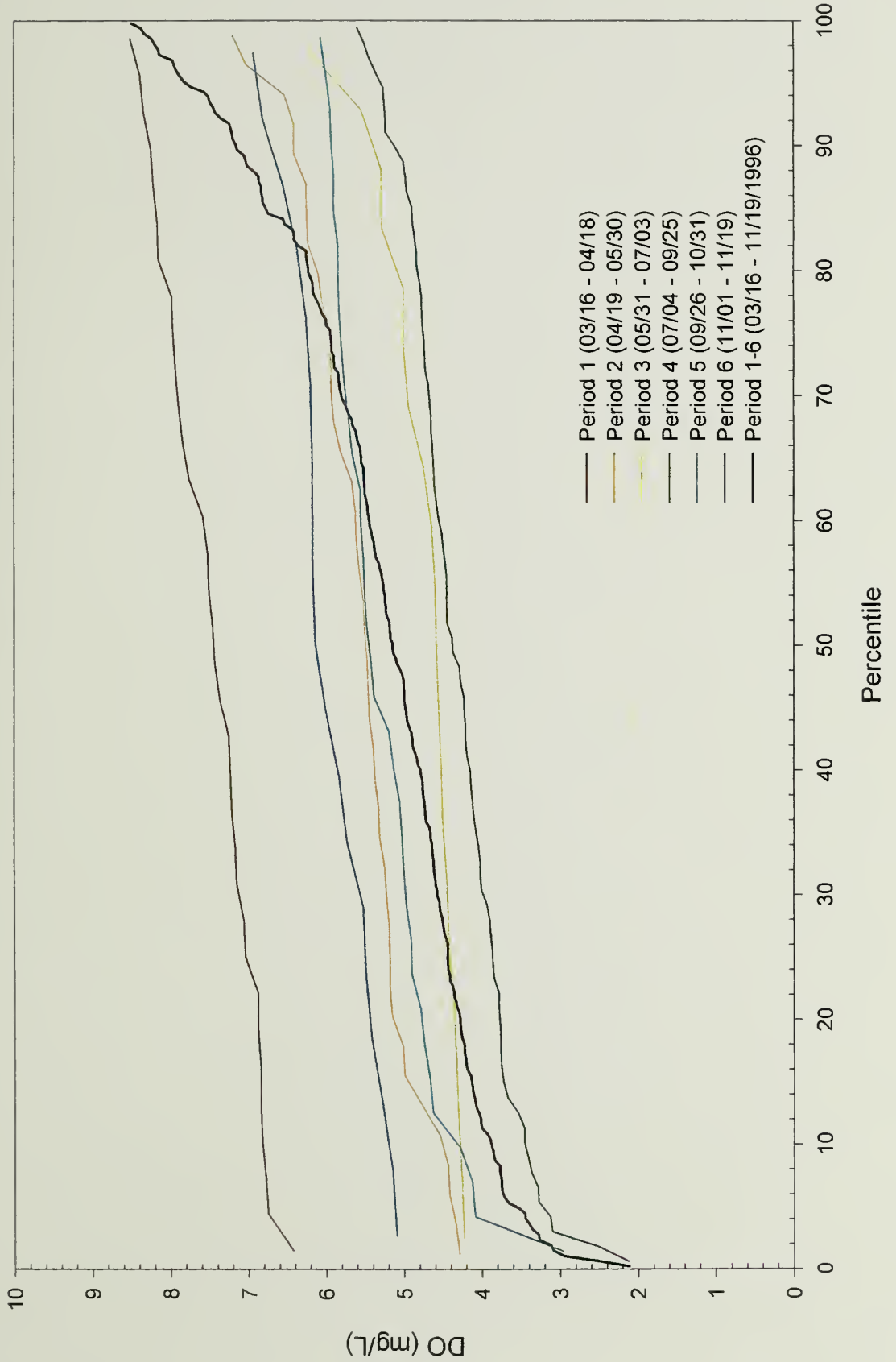

Station 21t (daily): Lockport Lock and Dam,
Chicago Sanitary and Ship Canal at RM 291.20

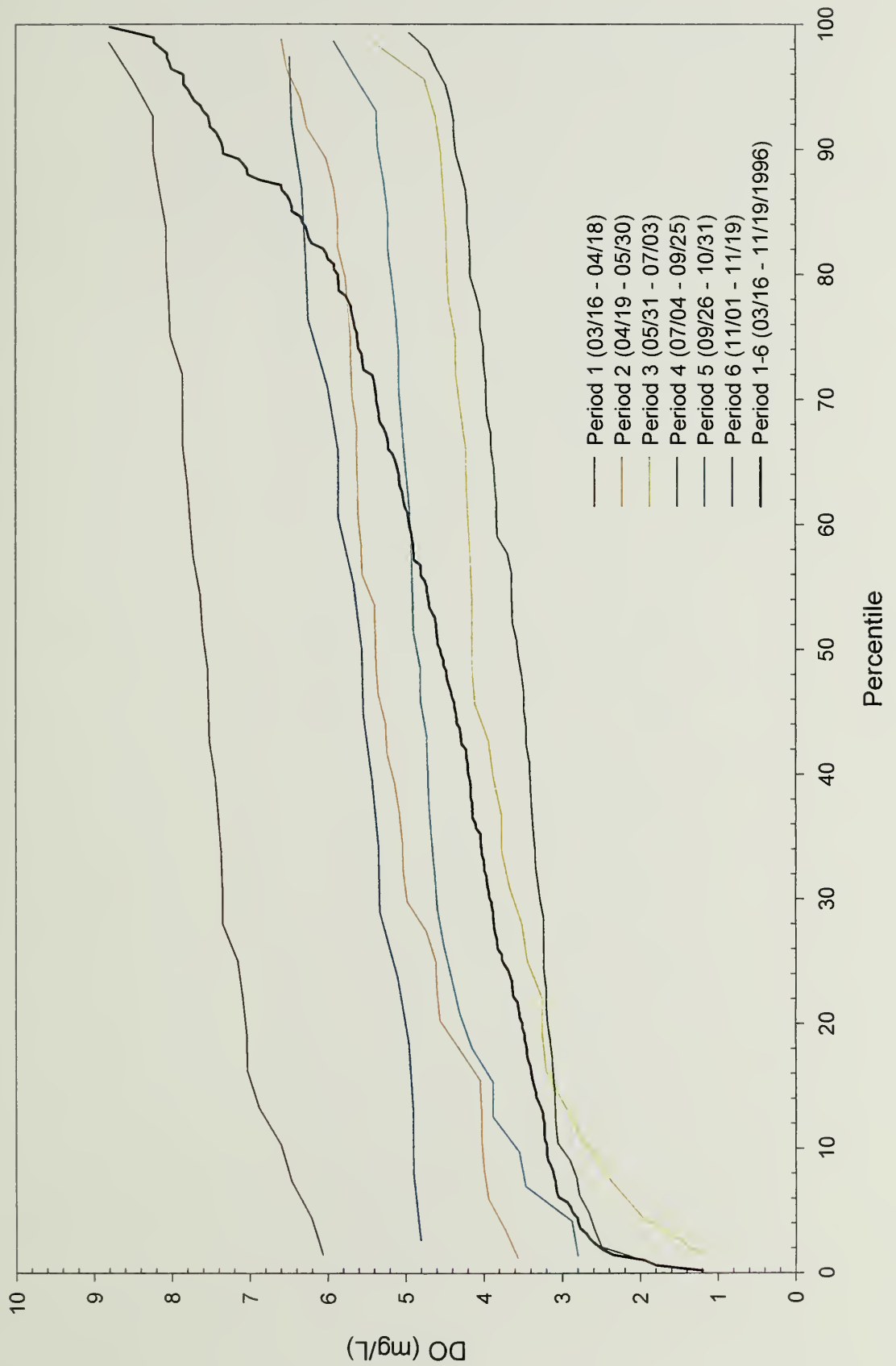

Station 21m (daily): Lockport Lock and Dam,
Chicago Sanitary and Ship Canal at RM 291.20

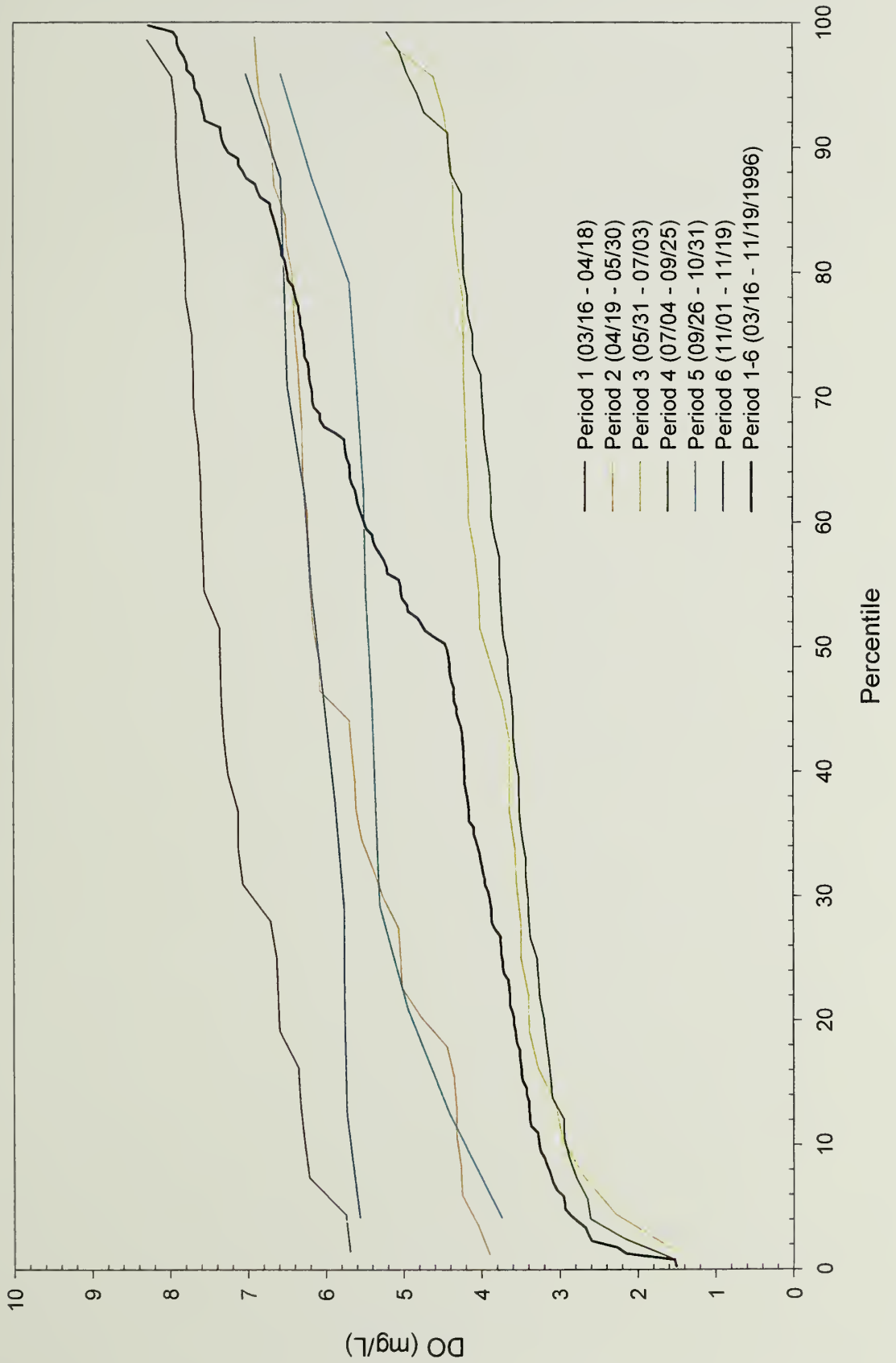

Station 21b (daily): Lockport Lock and Dam,
Chicago Sanitary and Ship Canal at RM 291.20

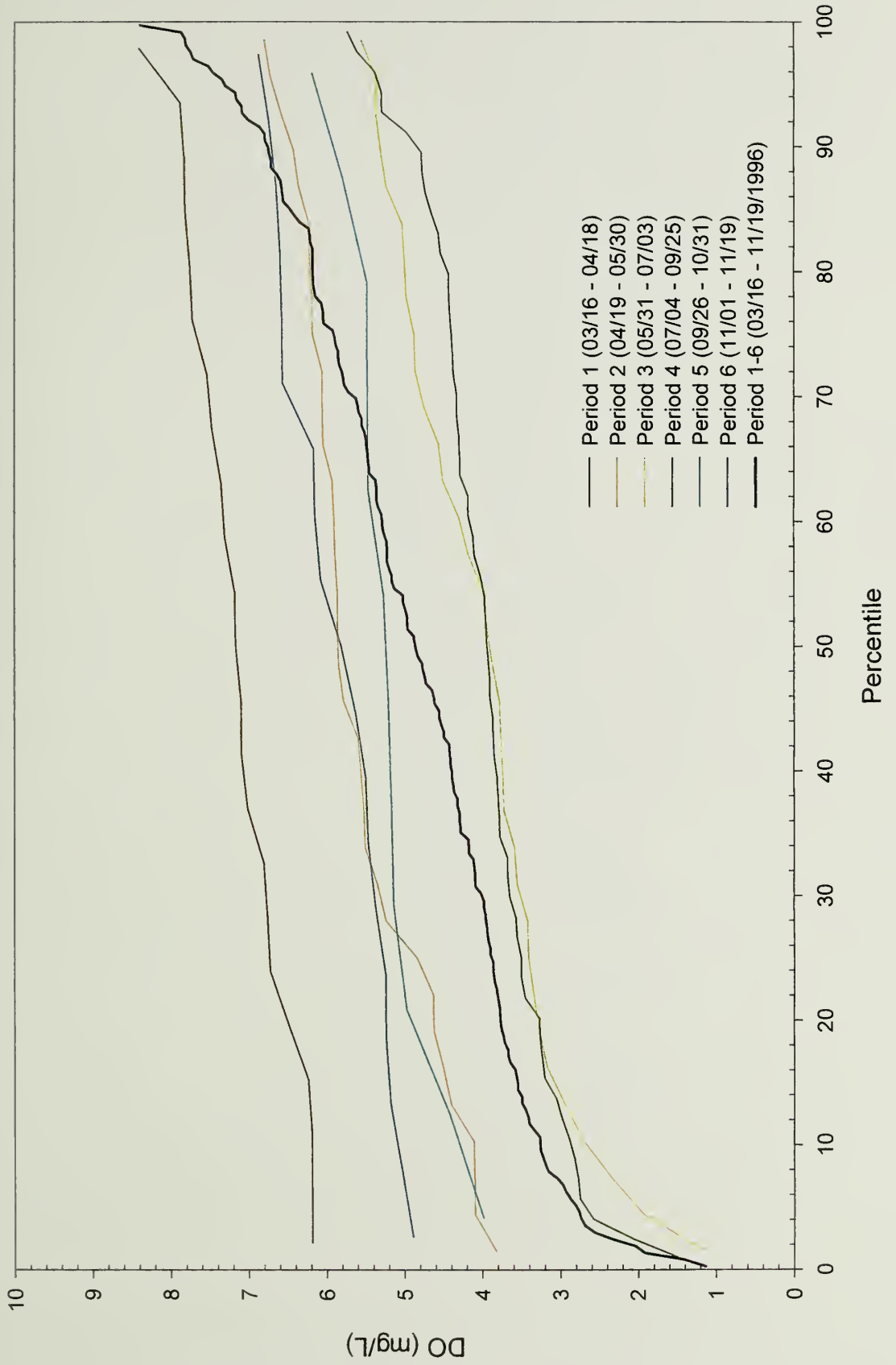



3 0112 104641185

ILLINOIS



DEPARTMENT OF
NATURAL
RESOURCES