

COOPERATIVE GROUNDWATER REPORT 7
ILLINOIS STATE WATER SURVEY
ILLINOIS STATE GEOLOGICAL SURVEY
Champaign, Illinois 61820

**PROCEDURES FOR THE COLLECTION OF
REPRESENTATIVE WATER QUALITY DATA
FROM MONITORING WELLS**

*James P. Gibb, Rudolph M. Schuller,
and Robert A. Griffin*

Prepared in cooperation with
Municipal Environmental Research Laboratory
U.S. Environmental Protection Agency

STATE OF ILLINOIS
DEPARTMENT OF ENERGY AND NATURAL RESOURCES

1981

**PROCEDURES FOR THE COLLECTION OF REPRESENTATIVE
WATER QUALITY DATA FROM MONITORING WELLS**

James P. Gibb, Rudolph M. Schuller, and Robert A. Griffin

STATE WATER SURVEY

STATE GEOLOGICAL SURVEY

In Cooperation with

**Municipal Environmental Research Laboratory
U.S. Environmental Protection Agency
Cincinnati, OH 45268**

COOPERATIVE RESOURCES REPORT

CHAMPAIGN, ILLINOIS

1981

STATE OF ILLINOIS
HON. JAMES R. THOMPSON, Governor

DEPARTMENT OF ENERGY AND NATURAL RESOURCES
FRANK H. BEAL, M.U.P., Director

BOARD OF NATURAL RESOURCES AND CONSERVATION

Frank H. Beal, M.U.P., Chairman
Walter E. Hanson, M.S., Engineering
Laurence L. Slow, Ph.D., Geology
H. S. Gutowsky, Ph.D., Chemistry
Lorin I. Nevling, Ph.D., Forestry
William L. Everitt, E.E., Ph.D.,
University of Illinois
John C. Guyon, Ph.D.,
Southern Illinois University



STATE WATER SURVEY
Stanley A. Changnon, Jr., *Chief*

STATE GEOLOGICAL SURVEY
Robert E. Bergstrom, *Acting Chief*

FOREWORD

This publication summarizes the results of research conducted by the State Water Survey and State Geological Survey. The research was funded (Contract No. R-806304-010) in part by the Solid and Hazardous Waste Research Division (SHWRD), Municipal Environmental Research Laboratory, Cincinnati, Ohio. Project officers were Donald Sanning of SHWRD, and Marion R. Scalf of the R. S. Kerr Environmental Research Laboratory, U.S. Environmental Protection Agency, Ada, Oklahoma.

The report has been reviewed by the U.S. Environmental Protection Agency and released for publication as a combined report. Approval does not signify that the contents necessarily reflect the views and policies of the U.S. Environmental Protection Agency, nor does mention of trade names or commercial products constitute endorsement or recommendation for use by any of the respective agencies.

The research summarized in this report is one component of the technical basis required to operate meaningful groundwater monitoring systems. As such, it should be useful to regulatory agencies, consultants, industry, and other researchers. Additional information on this study can be obtained by contacting the project officers or authors.

James P. Gibb
Head, Groundwater Section
Illinois State Water Survey

Rudolph M. Schuller
Assistant Geochemist
Illinois State Geological Survey

Robert A. Griffin
Head, Geochemistry Section
Illinois State Geological Survey

ABSTRACT

Data collected from six monitoring wells at waste disposal sites in Illinois were used to evaluate procedures for the collection of "representative" water samples from monitoring wells. The effects of four types of pumping mechanisms, the extent of well flushing, the rate and time of pumping, and storage and preservation techniques on chemical composition of water samples were studied. Pump tests and multiple sample experiments provided data on which recommended sampling protocols and sample preservation, preparation, and storage procedures are based.

The selection of the type of sampling device; sample preparation, preservation and storage; and sampling procedures all must be tailored to the size and accessibility of the individual well, its hydrologic and chemical character, the chemical constituents of interest, and the purpose for monitoring the site. Generally recommended sampling procedures include: 1) using peristaltic or submersible diaphragm type pumps when possible; 2) conducting pump tests prior to sampling to determine sampling frequency and time and rate of pumping; 3) flushing the well by pumping four to six well volumes; 4) measuring key parameters such as pH, specific conductance, oxidation-reduction potential, and alkalinity at the time of sample collection; and 5) filtering samples immediately on site through a 0.45 μm pore size filter and then preserving the samples immediately after filtration, according to U.S. EPA (1979) recommended procedures.

CONTENTS

	Page
Foreword.	ii
Abstract.	iii
Figures.	v
Tables.	vii
Acknowledgments.	viii
1. Introduction.	1
2. Conclusions.	5
3. Recommendations.	7
4. Site Selection and Descriptions.	9
5. Pumping Equipment..	17
6. Sample Collection and Preparation	19
7. Chemical Analytical Methods..	21
8. Factors Controlling Groundwater Quality.	22
9. Results.	26
Pump test analyses.	26
Effects of pumping mechanisms on chemical composition	35
Effects of well flushing on chemical composition	43
Effects of sample preparation, preservation and storage on chemical composition	53
References.	60

FIGURES

<u>Number</u>		<u>Page</u>
1	Generalized stratigraphic columns for sites 1-SDV, 2-ELG, 3-FLR, 4-TYL, and 6-DUP.	10
2	Typical well and air-lift pumping mechanism (after Walker, 1974).	18
3	Distribution of species for the $\text{CO}_2\text{-HCO}_3^- \text{-CO}_3^{-2}$ system in water (Manahan, 1972).	24
4	Site 1-SDV: time-drawdown data and theoretical curve	30
5	Aquifer yield curves for all six sites.	30
6	Site 2-ELG: time-drawdown data and theoretical curve	31
7	Site 3-FLR: time-drawdown data and theoretical curve	31
8	Site 4-TYL: time-drawdown data and theoretical curve	31
9	Site 6-DUP: time-drawdown data and theoretical curve	31
10	Percent of aquifer water versus time for different transmissivities.	34
11	Percent of aquifer water versus time for different well casing diameters.	34
12	Effects of pumping mechanism on iron concentrations at site 5-BRD as a function of well volumes pumped	38
13	Effects of pumping mechanism on iron concentrations at site 2-ELG as a function of well volumes pumped	39
14	Effects of pumping mechanism on iron concentrations at site 6-DUP as a function of well volumes pumped	40
15	Site 1-SDV: magnesium, cadmium and manganese concentrations versus volumes pumped (peristaltic pump)..	44
16	Site 1-SDV: selenium, arsenic, boron and copper concentrations versus volumes pumped (peristaltic pump)	45

Figures (cont'd)

<u>Number</u>		<u>Page</u>
17	Site 2-ELG: magnesium, potassium, sodium, and iron concentrations versus volumes pumped (peristaltic pump).	46
18	Sites 3-FLR and 4-TYL: sodium, calcium, magnesium and manganese concentrations versus volumes pumped (peristaltic pump).	47
19	Site 5-BRD: potassium, magnesium, manganese, zinc, and iron concentrations versus volumes pumped (peristaltic pump)	48
20	Site 5-BRD: iron and zinc concentrations versus volumes pumped for two sampling periods (peristaltic pump).	49
21	Site 6-DUP: iron concentrations versus volumes pumped for two sampling periods (peristaltic pump).	52
22	Sites 4-TYL, 5-BRD, and 6-DUP: chloride concentrations versus volumes pumped (peristaltic pump).	54

TABLES

<u>Number</u>		<u>Page</u>
1	Typical detection limits for ICP.21
2	Redox processes in an open system	25
3	Values of the function $F(\mu,)$27
4	Average pH values for the sixth, eighth, and tenth well volumes collected at each site by each pumping mechanism.36
5	Analysis of samples from sites 5-BRD and 6-DUP collected by four pumping mechanisms immediately after flushing ten well volumes.42
6	Analysis of samples from site 2-ELG where the well was placed in geologic materials of low hydraulic conductivity.	55
7	Analysis of samples from site 4-TYL where the well was placed in geologic materials of low hydraulic conductivity.	55
8	Sites 2-ELG, 3-FLR, 5-BRD, and 6-DUP: calcium, magnesium and sodium concentrations of samples filtered through different pore size membranes.57
9	Sites 5-BRD and 6-DUP: iron and zinc concentrations of samples filtered through different pore size membranes.	58
10	Sites 5-BRD and 6-DUP: analysis of the tenth well volume sample used for storage study.59

ACKNOWLEDGMENTS

This project was funded in part by the U.S. Environmental Protection Agency, Solid and Hazardous Waste Research Division, Municipal Environmental Research Laboratory, Cincinnati, Ohio (Grant No. R-806304-010). Special thanks go to Don Sanning and Dick Scalf, Project Officers, for their assistance during the project.

The authors wish to express their gratitude to the operators of the four landfills and two industries that permitted studies to be conducted on their property.

Special thanks go to Michael O'Hearn, Assistant Engineer at the Illinois State Water Survey, for his assistance in conducting pumping tests, collecting samples, and his work with the various types of pumps used in the study. Bill Bogner of the Illinois State Water Survey and Barry Fisher, Bill Roy, and Ivan Krapac of the Illinois State Geological Survey also assisted on various sampling runs. The authors also wish to thank Beverly Herzog and Keros Cartwright for contributing the geologic descriptions of the sites studied during this project.

Use of the inductively coupled argon plasma emission spectrograph was under the general supervision of Dr. Ken Smith, formerly of the Illinois State Natural History Survey, and is gratefully acknowledged.

SECTION 1

INTRODUCTION

Regulatory agencies are charged with the assignment of regulating the disposal of waste to insure that the environment is not adversely affected. To accomplish this task, it is necessary for these agencies to set design and operational standards based on available technology to minimize potential pollution. The operating disposal facilities must then comply with these standards. They also must monitor the effects of their operation on the surrounding environment. The use of wells or piezometers for collecting water samples and water level data has been, and probably will continue to be, the method for monitoring the effects of waste disposal facilities on groundwater.

Considerable research has been conducted to develop analytical laboratory techniques to detect the low levels of various constituents set forth in water quality standards. Water sample collection and preservation techniques have been established by several different laboratories and agencies in an attempt to insure that water samples delivered to the laboratory are chemically representative of the water sampled. However, there is considerable controversy among laboratories, agency policies, and researchers concerning proper techniques of sampling from monitoring wells and appropriate procedures for preserving the original chemical character of the samples. If monitoring wells and water samples are to provide the performance yardstick for disposal facilities' design and operation, the significance of the various sampling procedures and preservation techniques must be determined.

PREVIOUS WORK

Definite protocols can be established for collecting "representative" water samples from monitoring wells. First, it is necessary to select a pumping mechanism that is suitable to the physical limitations of the well (depth, diameter, and yield potential) and that not alter the chemical properties of the water during pumping. It also is necessary to determine when the water being pumped is representative of water contained in the aquifer and is not a mixture of aquifer water and unrepresentative "stagnant" water removed from storage in the well casing.

Once the sample has been taken, it must be decided whether key parameters will be measured on-site at the time of collection or in the laboratory some time later. If the sample is to be returned to the laboratory for analysis, the appropriate techniques of preparation, preservation, and storage must be selected to prevent the chemical composition of the sample from changing between the time of collection and the time of analysis. If the samples are to

be returned to the laboratory without preparation or preservation, the changes in chemical composition occurring during sample storage must be determined.

The choice of pumping mechanism usually is dependent on the diameter of the well, volume of water in the well, depth to water, yield potential of the well, and accessibility of the site. Mooij and Rovers (1975) suggested that a bailer was the best overall water sampling device. However, as Fenn et al. (1977) pointed out, removing a large volume of stagnant water from a well with a bailer can become tedious. It also can become difficult to obtain and measure a steady pumping rate when using a bailer. Using a peristaltic pump eliminates these problems but requires a power source which could cause difficulties when sampling in more remote areas. Peristaltic pumps also are limited in their lift capacities to a theoretical maximum of 9.75 m (32 ft), making sampling from wells with deeper water levels impossible. Although submersible pumps are designed for sampling at greater depths, these are not usually constructed to fit in a small-diameter monitoring well (diameter <2 in.). Walker (1974) designed a sampling device that uses an air compressor or bottled compressed gas to lift a water sample from a monitoring well at greater depths. Sommerfeldt and Campbell. (1975) and Trescott and Pinder (1970) have used similar pumping mechanisms employing gasoline-powered air compressors to sample from as deep as 190 feet. Mooij and Rovers (1975) stated that the effect of the air-lift pumping mechanisms on the chemical composition of a sample collected with an air-lift system was unknown. Wood (1970) and Summers and Brandvold (1967) have, however, cautioned against the exposure of groundwater samples to air. Wallich (1977) showed that exposure of groundwater to the atmosphere resulted in erroneous values for pH, alkalinity, and iron in groundwater samples. Although several studies have been directed toward studying the effects of exposing a groundwater sample to atmospheric conditions, little has been done toward studying the effects of sample collection systems on the chemical composition of groundwater samples.

After selecting the type of pumping mechanism to use, the extent of well flushing needed to clear the stagnant storage water from the well must be determined. Summers and Brandvold (1967) were among the first to document the need to flush a well before collection of a groundwater sample. Although their work involved high volume flowing wells and not shallow monitoring wells, the results showed that pH, temperature, and specific conductance gradually changed with increasing volumes of water pumped until steady values were obtained. Schmidt (1977) also established the need for flushing large capacity wells, but like the previous researchers ventured no estimate of the volume of water to be removed before a representative sample of aquifer water could be taken.

Several investigators have attempted to establish sampling routines for shallow monitoring wells. Hughes et al. (1968) noted the need for flushing a monitoring well before collection of groundwater samples and recommended that two well volumes be pumped. (Well volume constitutes the initial volume of water in the well casing prior to pumping.) Gilkeson et al. (1977) found that reductions in Fe, Pb, Zn, Cu, Cd, and Cr concentrations occurred in collected samples after well flushing. For wells which cannot be pumped dry, Mooij and Rovers (1975) recommend pumping five well volumes before collecting a sample. For wells installed in materials of low hydraulic conductivity, they further

recommend that the well should be pumped dry and allowed to refill before sampling.

Fenn et al. (1977) developed a comprehensive scheme for well flushing, dependent upon the yield potential and the positioning of the pump intake, for wells that could not be pumped dry. They recommended a minimum flushing of one well volume, but preferably three to five well volumes. Mooij and Rovers (1975) and Fenn et al. (1977) recognized the need for well flushing and the dependence of its magnitude on the hydrogeology of the site.

Other considerations for proper sampling are the procedures for sample preparation, preservation, and storage. Hughes et al. (1968), Brown et al. (1970), Chian and DeWalle (1975), and Jackson and Inch (1980) all suggested that certain parameters should be measured on-site at the time of sample collection, since parameters such as pH, specific conductance, temperature, oxidation-reduction potential, and dissolved oxygen are all likely to undergo change before the samples can be transported to the laboratory for analysis.

Once key or target parameters have been determined, the samples must be prepared and returned to the laboratory for analysis. The United States Environmental Protection Agency (1979) recommends filtering groundwater samples through a 0.45 μm pore size membrane on-site immediately after collection unless field filtration is impractical. Field filtration, like measurement of the key parameters, requires transporting additional equipment to the sample collection site. If returning the samples to the laboratory without filtration and preservation would result in no chemical changes, there would be a considerable savings in time and expense. This savings, however, must not be made at the expense of the chemical integrity of the samples. Sample preservation by acidification before filtration is well recognized as causing increased concentrations of clay-related and other colloidal constituents.

The use of the 0.45 μm pore size membrane for filtration of environmental water samples has been universally accepted. However, Kennedy et al. (1974) demonstrated that clay sized particles could pass through 0.45 μm pore size membranes, resulting in increased concentrations of Al, Fe, Mn, and Ti. In a similar study, Wagemann and Brunskill (1975) saw an increase in Al and Fe concentrations in solutions filtered through 0.45 μm pore size membranes, but no changes in Mn and Tl. The use of smaller pore sized membranes would reduce the passage of clay sized particles, but also could greatly increase the filtration time for turbid samples.

Once the samples have been filtered they must be split into aliquots and preserved. Struempfer (1973), Rattonetti (1976), and Subramanian et al. (1978) found it necessary to acidify aqueous samples to a pH <2.0 to avoid loss of cations from solution by precipitation and adsorption on container walls. The U.S. EPA (1979) has established techniques for the preservation of most constituents found in waters and waste waters. Struempfer (1973) and Shendrikar et al. (1975) were among many others who have studied the adsorption characteristics of materials used for sample containers. They found that linear polyethylene and glass were the best storage vessels for aqueous samples for which inorganic constituents were to be determined.

PURPOSE AND SCOPE OF STUDY

The three principal purposes of this study were: 1) to determine if current sampling methods produce samples that are representative of water contained in the aquifer or water-bearing strata being monitored; 2) to determine if groundwater samples collected in the field must be treated (filtered and acidified) on location, or if they can be brought back to the laboratory for treatment without altering their chemical nature; and 3) to determine which sampling and preservation techniques should be accepted as standards for monitoring well sampling. In order to fulfill these purposes, the following specific objectives were set:

- 1) Determine the hydrologic properties of the materials tapped by each monitoring well studied.
- 2) Determine a pumping scheme for each well to obtain water samples representative of the aquifer or water-bearing strata being monitored.
- 3) Collect a series of samples from each well using four different pumping methods.
- 4) Determine the effects that the pumping mechanism, time and rate of pumping, and preservation techniques have on the chemical composition of the samples collected.
- 5) Recommend monitoring well sampling procedures and sample preservation techniques for specific chemical constituents.

Because of the enormous quantity of data produced by the above scheme, certain sampling practices had to be accepted. All of the samples were preserved according to the U.S. EPA's (1979) recommended procedures. Also, all of the samples were stored in linear polyethylene bottles. These practices were well documented in the literature as not being detrimental to a sample's integrity for short time periods. During the collection, preparation, preservation, and storage of the samples, no new procedures or equipment were used. The purpose of this project was to analyze existing procedures and equipment that were available.

SECTION 2

CONCLUSIONS

The results of this study make it apparent that collecting "representative" water samples from monitoring wells is not a straightforward or easily accomplished task. Each monitoring well has its own individual hydrologic and chemical character that must be considered when planning a sampling protocol. The selection of the type of sampling device; sample preparation, preservation, and storage; and sampling procedures all must be tailored to the size and accessibility of the individual well, its hydrologic and chemical character, the chemical constituents of interest, the time of year, and the purpose for monitoring.

It has been demonstrated that meaningful pump tests can and, should be conducted on monitoring wells. The analyses of time-drawdown data from constant rate pump tests using the equations developed by Papadopoulos and Cooper (1967) yielded realistic transmissivity values for the materials tapped by the monitoring wells studied. The determined transmissivities were used to project time-drawdown relationships at various pumping rates and to determine the percent of "aquifer water" contained in the total amounts pumped at any given time. These relationships should be used as guides for obtaining "representative" water samples from monitoring wells.

The transmissivity values are also invaluable when attempting to determine times of travel of groundwater within the aquifer or materials being monitored. By applying appropriate hydraulic gradients, porosities, and transmissivities, the Darcy and real velocities of groundwater movements can be estimated. These velocities can be used to project the rate of migration of pollutants detected in the monitoring well and to describe the geometry and dynamics of the contaminate plume. The velocity of regional groundwater flow should be used to determine realistic and economic frequencies for sample collection. In very "tight" materials (those with low transmissivities) the rates of groundwater movement may be on the order of 0.2 to 1.5 meters (1 to 5 feet) per year. If monthly sampling is prescribed in a case such as this, the same "slug" of water may be sampled for 2 or 3 months consecutively.

Chemical data from samples collected with the four types of pumps used in this study indicated that peristaltic pumps and bailing yielded comparable data and resulted in the least changes in chemical quality of water delivered to the surface. Air- and nitrogen-lift pumping mechanisms increased the pH of water samples during pumping and altered the concentrations of several chemical constituents. Iron and zinc were shown to be particularly sensitive to the use of these types of pumps.

The effects of flushing or pumping a well for a period of time to insure collection of a "representative" sample also have been effectively documented.

In most cases, the water stored in the well casing was of different chemical quality than that contained in the aquifer to be sampled. Usually, the oxidizing environment in the well was sufficiently different from that of the aquifer to create a shift of chemical species in solution.

To insure that a "representative" water sample is collected, the well should be pumped until a high percentage of "aquifer water" is obtained. The length of time of pumping depends on the rate of pumping, well diameter, and transmissivity of the aquifer being sampled. Given these factors, the aquifer water percentages with time can be calculated from the examples in this report and used as a guide for determining the appropriate pumping time before a sample is collected. Monitoring pH while pumping with a peristaltic pump or bailer appears to be a reasonable field check for assuring that a "representative" water sample is being collected. For monitoring wells that can easily be pumped dry, the limited data collected in this study suggest that representative samples can be taken by pumping the well dry and then collecting the sample as the well refills. To insure that the collected samples are truly "fresh" aquifer water flowing into a dewatered well, it is suggested that the water levels in the well be monitored and the sample collected while the water levels are still rising.

Data collected from the same monitoring wells at different times of the year show that significant seasonal variations in chemical quality can occur. These changes can be related to varying rates of recharge and changes in oxidation-reduction conditions in relatively shallow aquifer systems. Awareness of the possibilities of these types of seasonal variations is essential to understand and properly interpret the significance of changes in water quality with time.

Changes in field-measured pH or specific conductance values from one sampling period to another should be expected and are not causes to abandon established sampling procedures. To insure that "representative water samples" are obtained, the time and rate of pumping should be the same each time a particular well is sampled.

Data from the sample preparation, preservation, and storage portions of the study show that when chemical concentrations for certain constituents are desired, samples definitely should be filtered in the field at the time of collection. Chemical constituents sensitive to pH changes can be affected within 7 hours if not filtered and preserved at the time of collection. The constituents found to be most sensitive were Fe and Zn.

In addition, the selection of filter pore sizes used to filter samples can affect the results of the chemical analyses. Mineral constituents associated with clay and colloidal particles increased significantly when the samples were filtered through 3.0 μm pore size membranes. Samples filtered through 0.45 μm pore size membranes had only slightly higher clay and colloidal particle-related mineral values over those filtered through 0.22 μm pore size membranes. For practical purposes, the differences in chemical composition were small and the use of the 0.45 μm pore size membrane appears satisfactory. Use of the smaller pore size filters was more time consuming and resulted in filter clogging problems, particularly for turbid samples.

SECTION 3

RECOMMENDATIONS

On the basis of this study the following recommendations are made:

- 1) A brief 2 or 3 hour pumping test should be conducted on each monitoring well to be sampled. Analyses of the pump test data and other hydrologic information should be used to determine the frequency at which samples will be collected and the rate and period of time each well should be pumped prior to collecting the sample.
- 2) The general rule of thumb of pumping 4 to 6 well volumes will in most cases produce samples representative of aquifer water. For aquifers with unusually high transmissivities, pumping for periods long enough to remove the "stagnant" water column may induce migration of water from parts of the aquifer remote from the monitoring well. The calculations of percent aquifer water with time provide a more rational basis on which the length of pumping can be determined. Samples should be collected in the minimum time required to produce water representative of the aquifer.
- 3) A controlled sampling experiment, similar to those in this study, preferably using a peristaltic or submersible diaphragm type pump, should be conducted to accurately determine the chemical quality of the aquifer water and to verify the response of the monitoring well to pumping as predicted from the pump test data. Once the chemical character and responses of the monitoring systems have been determined, key chemical constituents for routine sampling can be selected.
- 4) Based on the sensitivity of the selected chemical parameters, a choice of pumps for routine sampling can be made. The use of air- or nitrogen-lift pumping mechanisms should be restricted to chemical constituents insensitive to oxidation-reduction reactions and changes in pH. Although this study dealt with inorganic constituents, the data suggest that these types of pumping mechanisms probably would also strip volatile organic compounds from the water during pumping. The peristaltic or submersible diaphragm pumps and the bailer are recommended for most applications. If a bailer is to be used, the procedures outlined in the results sections of this report should be followed.
- 5) The monitoring well should be pumped at a constant rate for a period of time that will result in delivery of at least 95 percent aquifer

water. The rate and time of pumping should be determined on the basis of the transmissivity of the aquifer, the well diameter, and the results of the sampling experiment.

- 6) Measurements of pH, Eh, and specific conductance should be made at the time of sample collection. These measurements should be made within a closed cell, which will prevent the sample from coming into contact with atmospheric conditions. All samples should be promptly filtered through a 0.45 μm pore size membrane and preserved according to recommended U.S. EPA procedures for the chemical constituents of interest.

In addition to the specific recommendations for establishing sampling procedures and sample preparation and preservation protocols noted above, the following general recommendations and suggestions for additional research needs are offered:

- 1) Studies should be conducted to develop optimized sampling procedures for monitoring groundwater for organic compounds.
- 2) Additional studies are needed to develop sampling procedures for geologic strata and materials of very low hydraulic conductivity and for monitoring wells that can easily be pumped dry.
- 3) Studies also should be undertaken to investigate the effects of seasonal and other natural variations in chemical quality of groundwater on sampling protocols and the interpretation of data from monitoring wells.
- 4) Studies are also needed to develop in-situ sampling procedures and apparatus to minimize the possible artificial introduction of contaminants into the well during the monitoring procedure itself.

SECTION 4

SITE SELECTION AND DESCRIPTIONS

Monitoring wells at six sites in the State of Illinois were selected for study. Two sites are active sanitary landfills; two are inactive landfills; one is a stack scrubber lagoon for a secondary zinc smelter; and one is an anaerobic digestion lagoon for a hog processing plant. The wells at all sites were installed prior to this study, and all but one were constructed by persons other than the authors. Five are cased with PVC pipe, either 3.81 or 5.08 cm (1-1/2 or 2 in.) diameter. The sixth well is cased with 5.08 cm (2 in.) diameter galvanized iron. The well depths range from about 5 to 10 m (16 to 30 ft) and have nonpumping water levels from 0 to 5 m (0 to 16 ft) below land surface.

Factors considered in selecting the sites included: 1) accessibility of the monitoring well to vehicles so that pumping tests and sampling could be accomplished with equipment using generated electricity without undue hardship; 2) the physical characteristics of the monitoring well and geology of the location; 3) the potential yield capability of the materials tapped by the monitoring well; and 4) the chemical quality of water obtained from the monitoring well.

SITE 1 - SANDOVAL (1-SDV)

Site 1-SDV is a secondary zinc smelter located in south-central Illinois. It has been in operation since about 1885. In compliance with air pollution control regulations, a scrubber was installed on the emission stack at the plant in 1970. The scrubber waste water is disposed of in a surface impoundment built on a cinder fill derived from early smelting operations. A series of monitoring wells were constructed on the plant property in 1974 and 1975 (Gibb et al., 1978). The monitoring well chosen for use in this study was well no. 12, a 5.08 cm (2 in.) diameter well 4.25 m (14.0 ft) deep. The well is cased with PVC pipe and has slots sawed in the bottom 61.0 cm (2 ft). The well is located about 4.6 m (15 ft) downgradient from the scrubber waste disposal pond. Figure 1 shows the material encountered at this site.

The surficial materials at the site are wastes from early smelting operations. These wastes are cinders and wind-blown ash which are rich in zinc and other heavy metals and which range in thickness from 0.305 to 3.05 m (1 to 10 ft) on the Sandoval property.

Glacial material that underlies the cinders is about 18.3 m (60 ft) at the well and thickens to 22.9 m (75 ft) on the west side of the smelter prop-

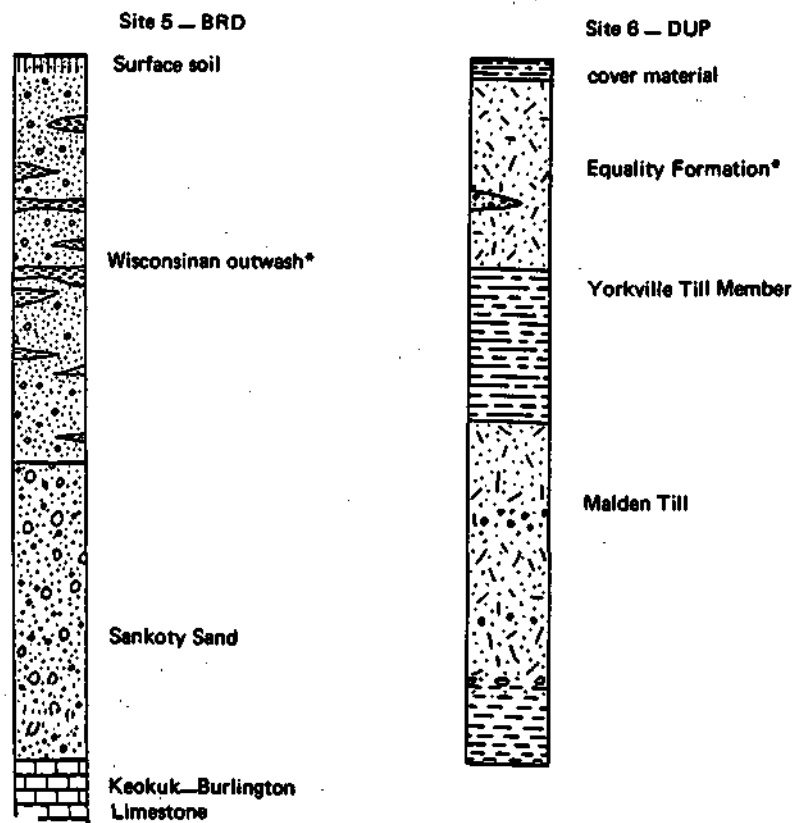
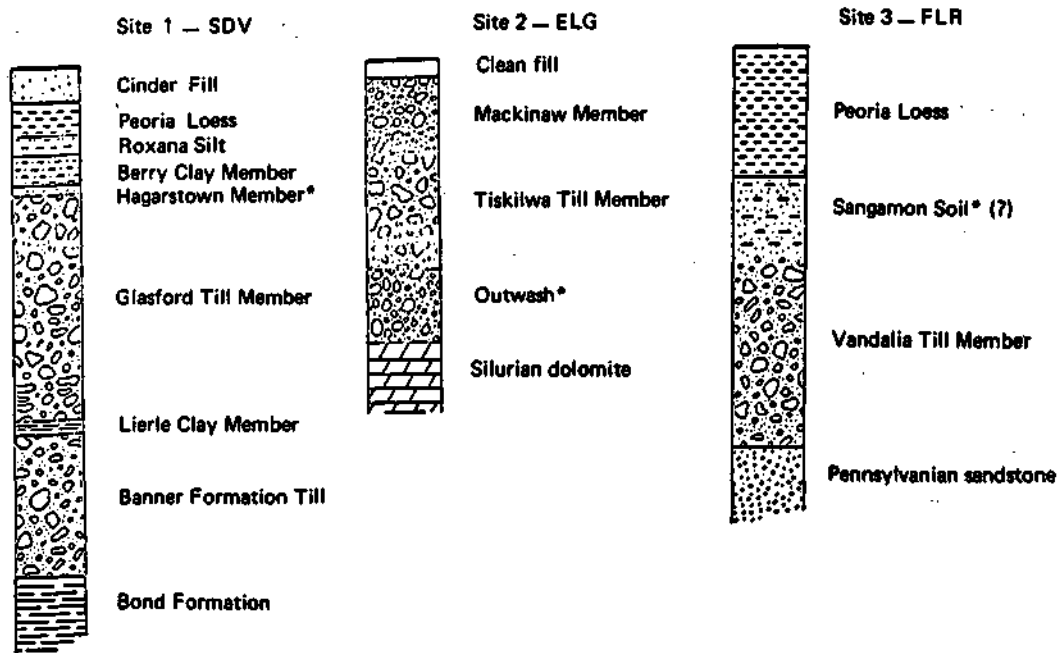

* Stratigraphic unit in which the monitoring wells are finished

Figure 1. Generalized stratigraphic columns for sites 1-SDV, 2-ELG, 3-FLR, 5-BRD, and 6-DUP

erty. The stratigraphic units recognized in the drift are essentially flat lying, uniform in character, and mostly of low hydraulic conductivity.

The uppermost stratigraphic unit in the glacial drift is 1.2-1.8 m (4-6 ft) of a brownish-gray clayey silt called the Peoria Loess. Expandable clay (montmorillonitic) material content averages nearly 85 percent in the loess. The remaining material is predominantly illite and sand. A modern soil profile has developed in the loess.

Less than 1.5 m (5 ft) of Roxana Silt, a dark-brown clayey silt, underlies the Peoria Loess. While the clay mineral content is similar to that of the loess above, the sand content averages 20 percent and may be as much as 34 percent. The lower part of the modern soil profile is probably in the Roxana Silt.

The Glasford Formation lies below the Roxana Silt and has three identifiable members in this area. The uppermost member, the Berry Clay Member, consists of 0.9-1.5 m (3-5 ft) of dark gray silty sandy clay with a trace of gravel. The clay mineral content is similar to that of the overlying loess units, but the sand and gravel percentages increase toward the base. The clay is rich in organic material and iron staining but is lacking in carbonates.

The Hagarstown Member, below the Berry Clay, is the most permeable zone. It consists of 0.3-0.6 m (1-2 ft) of silty sand with some gravel. Its clay content is similar to that found in the Glasford Formation Till below; the sand content is variable and may be as much as 50 percent. The monitoring well used for the study is finished in the Hagarstown Member, which is 45 cm (18 in.) thick at this location.

The Glasford Formation Till comprises approximately 6.1-13.1 m (20-43 ft) of gray to dark gray sandy and silty glacial till. Its thickness is approximately 9.8 m (32 ft) at the test site. Both illite and sand content decrease with depth. Lenses of dark olive-brown leached clay are locally present, as are discontinuous lenses of sand and silt. The Sangamon Soil was formed in the two upper members of the Glasford Formation and in the upper part of the Glasford Formation Till.

The lowest glacial unit present is the Banner Formation, which contains the Lierle Clay Member and the Banner Formation Till. A dark olive-brown silty clay, the Lierle Clay is less than 1.2 m (9 ft) thick. Sand content averages 24 percent, while clay mineral composition is variable. The Banner Formation Till is 3.0-8.8 m (10-29 ft) of gray to pinkish-gray sandy, silty clay till with some gravel. Carbonates are present except locally at the top. Shale fragments and discontinuous sand and silt lenses also occur.

The Bond Formation of Pennsylvanian age forms the bedrock at this site. It is a green shale containing abundant mica. Kaolinite and illite content is high, while montmorillonitic clay content is low.

SITE 2 - ELGIN (2-ELG)

Site 2-ELG is an inactive landfill now used as a county forest preserve. The site originally was a gravel pit, and filling began in 1948 as an open burning dump. In later years controlled filling and covering was undertaken until the site was closed in about 1970. Forty percent of the fill material reportedly is household and garden refuse; 60 percent is industrial waste (Hughes et al., 1971).

The well chosen for use in this study is LW1B constructed in 1967 by Hughes et al. (1971). The well is 3.81 m (1-1/2 in.) in diameter and 7.92 m (26 ft) deep). The well is cased with PVC pipe and has a 91.4 cm (3 ft) screen at depth between 7.01 and 7.92 m (23 and 26 ft). The well is located about 76.2 m (250 ft) downgradient from the eastern edge of the old landfill and within 15 m (50 ft) of the Fox River.

The materials encountered at this site include clean fill and glacial drift. These materials dip eastward west of the monitoring well, but are relatively flat-lying at the site. Depth to bedrock is approximately 15 m (49 ft). Figure 1 shows the sequence of materials encountered.

The surficial material (Mackinaw Member) consists of 0.6-0.9 m (2-3 ft) of clean fill material. The fill is a non-calcareous, clayey to sandy silt. It was most likely derived from the brown to black silt and fine sand that originally formed the top soil in the area.

Below the Mackinaw Member is 3.7-6.4 m (12-21 ft) of the Tiskilwa Member of the Wedron Formation. The Tiskilwa Till Member is a calcareous, pinkish-gray to reddish-brown clay loam till. Gravel is present at scattered locations. At the base of the till, 1.8-4.6 m (6-15 ft) of medium to coarse gravel outwash with abundant dolomite is present at most locations. The monitoring well used in this study is finished in this outwash at the base of the Tiskilwa Till Member above the bedrock.

Silurian dolomite forms the bedrock in the Elgin area. It is fractured and used as an aquifer in the area.

SITE 3 - FLORA (3-FLR)

Site 3-FLR is an active landfill located in the clay pan area of southern Illinois. Landfilling operations began in about 1976. The materials being buried are principally household and garden refuse. No significant industrial waste is permitted for disposal at this site.

The well chosen for study is the northeast well being used for routine monthly monitoring in accordance with Illinois EPA guidelines. The well is 5.08 cm (2 in.) in diameter, is 5.88 m (19.30 ft) deep, and has a 61.0 cm (2 ft) screen between depth of 5.27 and 5.88 m (17.30 and 19.30 ft). It is cased with PVC pipe.

No driller's log is available for the well and there are few well logs from the area to show the geology of the site. The well logs available for the surrounding area are driller's logs and are very sparse in detail.

Available data indicate that the area is characterized by a loess and a till unit overlying a sandstone bedrock. The total drift thickness is less than 15 m (50 ft) thick. Figure 1 shows the materials found in the vicinity of the site.

The surficial deposits consist of an average of about 4 m (13 ft) of wind-blown Peoria Loess. It is described by drillers as yellow clay. Regional evidence suggests the loess is massive and contains the modern soil profile.

Below the Peoria Loess there is assumed to be an average of 1.5 m (5 ft) of Sangamon Soil. The Sangamon Soil is a weathered zone with a range of characteristics similar to, but more highly developed than, a modern soil. It is a sandy clay but may be coarser or finer-grained. The landfill operator reported the monitoring well used in this study to be finished in a thin sand layer (probably Sangamon Soil) overlain by clay and till.

The lowest geological unit present is the Vandalia Till Member of the Glasford Formation. Near Flora, it is a medium-grained, relatively silty, compact till. The density increased greatly toward the base. Thin sandy and pebble zones are common. On the driller's logs, this unit is commonly referred to as blue clay or shale.

Pennsylvanian aged sandstone forms the bedrock in this area. The sandstone is the main source for small domestic wells in the area.

SITE 4 - TAYLORVILLE (4-TYL)

Site 4-TYL is an active landfill located in central Illinois. Landfilling operations began in about 1975. The materials being buried reportedly are about 70 percent household and garden refuse and about 30 percent light industrial wastes.

The well chosen for use in this study is the "northwest" monitoring well being used for monthly monitoring. The well is 5.08 m (2 in.) in diameter and 12.01 m (39.4 ft) deep. The well is cased with PVC pipe and has a 61.0 cm (2 ft) screen between the depths of 11.40 and 12.01 m (37.4 and 39.4 ft).

The landfill is located in two geological terrains: the Shelbyville Moraine and the edge of the flood plain of the South Fork of the Sangamon River. The valley is eroded glacial till that has been filled in with outwash and alluvium. The valley fill thickness is variable and contains large amounts of sand. The sands generally lie between finer-grained sediments above and older tills on bedrock below.

The upland area is mostly till covered by loess. Since the area is near the terminus of the moraine, soils are erratic both in type and distribution.

The soils encountered vary from mixtures of clays, silts, sand, and fine gravel (glacial tills) to fine, silty sands of alluvial origin. The material encountered in nearby borings all had a low permeability. Depth to bedrock beneath the moraine ranges between approximately 7.6 and 46 m (25 and 150 ft). The bedrock is a soft, dark shale of Pennsylvanian age.

No driller's log is available for the well and only one driller's log showing the unconsolidated material was on record for the quarter section. The recorded well was drilled in 1941 and was located on the moraine in the NE 1/4 SE 1/4 SE 1/4 Section 13, T.13N., R.3W. The upper portion of its log reads as follows:

	Thickness	Depth
Clay, yellow	6.1 m (20 ft)	6.1 m (20 ft)
Sand, gravel and clay	3.05 m (10 ft)	9.15 m (30 ft)
Hardpan and sandy clay	11.90 m (39 ft)	21.05 m (69 ft)
Hardpan	3.36 m (11 ft)	24.40 m (80 ft)
Shale, soft, dark	1.53 m (5 ft)	25.95 m (85 ft)

From top to bottom these units most likely are Peoria Loess, Sangamon Soil, Vandalia Till (both units described as hardpan) and Pennsylvanian shale. The landfill operator reported the well to be finished in a slightly sandy clay zone 12.01 m (39.4 ft) deep (probably Vandalia Till) overlain by clay and till (probably Sangamon Soil), as illustrated by the sequence for site 3-FLR shown in Figure 1.

SITE 5 - BEARDSTOWN (5-BRD)

Site 5-BRD is a hog processing plant located in western Illinois. Liquid slaughter and processing wastes are routed through a 3-stage lagoon system and then either irrigated onto grain crops or discharged to the Illinois River.

The well chosen for use in this study is well 11, used by the plant personnel to monitor the effects of their disposal operation on groundwater. The well is 5.08 cm (2 in.) in diameter and 8.43 m (27.65 ft) deep. The well is cased with galvanized iron pipe and reportedly has a 61.0 cm (2 ft) screen between the depths of 7.82 and 8.43 m (25.65 and 27.65 ft). The well is located approximately 61 m (200 ft) downgradient from the first stage anaerobic lagoon.

Driller's logs for the area indicate that the bedrock is more than 30 m (100 ft) below the ground surface. The predominant unconsolidated deposits are about 15 m (50 ft) of sand extending from the surface and 15 m (50 ft) of gravel below. The character of the subsurface deposits is relatively uniform and highly permeable. Figure 1 shows the materials expected at Beardstown.

Top soil was noted on only one log in the Beardstown area. No description was provided of this soil, although regional data suggest that it is loess.

Wisconsinan outwash, 10.7-24.3 m (35-80 ft) thick, is present beginning at or near the surface throughout the area. The outwash is mainly medium to coarse sand, although fine sand has been noted near the top or base of the deposit. A discontinuous, relatively thin, clayey silt layer is found at depths of 1.5 to 4.6 m (5-15 ft) below the land surface in much of the area. The monitoring well used in this study is finished at a depth of 8.43 m (27.65 ft) in the Wisconsinan outwash.

The Sankoty Sand beneath the outwash is at least 6.7-18.3 m (22-60 ft) thick. No wells on file have penetrated the base of this sand in this area. In many locations the sand is actually a fine to coarse gravel deposit with some discontinuous lenses of fine to coarse sand. Large capacity wells (3790 to 5685 Lpm, or 1000 to 1500 gpm) are commonly constructed in this unconsolidated aquifer system.

Mississippian-age Keokuk-Burlington Limestone forms the bedrock in the area. Although no data are available on the limestone in this area, it is generally crinoidal limestone interbedded with fine-grained limestone, argillaceous dolomite and calcareous gray shale.

SITE 6 - DU PAGE (6-DUP)

Site 6-DUP is an inactive landfill located in northeastern Illinois. Filling by the trench and fill method began in 1952 and was completed by the end of 1966 (Hughes et al., 1971). Household and garden refuse was the major component of the fill, but small amounts of spent battery acid, construction debris, and sewage sludge were also buried at the site. The maximum thickness of this debris is about 6 m (20 ft).

The well chosen for study is MM 63, constructed in 1968 by Hughes et al. (1971). The well is 3.81 cm (1-1/2 in.) in diameter and 5.12 m (16.8 ft) deep. It is cased with PVC pipe and has a 30.5 cm (1 ft) screen at depths from 4.82 to 5.12 m (15.8 to 16.8 ft).

The DuPage site lies on a flat upland area between two moraines. The area was originally swampy and is drained by tiles into a creek flowing along the east side of the property. The general sequence of earth materials at the site consists of an upper surficial silty sand overlying till, which lies on dolomite bedrock. The materials slope gently to the east. Figure 1 shows the expected materials at DuPage.

The surficial material at the landfill site consists of 0.6-0.9 m (2-3 ft) of cover material comprised of clay loam, clay, silty clay loam and silt loam. Around the landfill, silty clay loam and clay loam of the Richland Loess constitute the surficial deposits.

Below the landfill is Equality Formation sand, which is probably outwash from the eastern moraine. The upper sand is a sandy silt to a silty sand and is up to 6.4 m (21 ft) thick below the landfill. This thickness decreases toward all edges of the landfill. A sand and gravel bar is present in the southeast corner of the landfill, and other bars are scattered in the field

south of the till. The monitoring well used in this study penetrates the landfill refuse and is completed in a 1.22 m (4 ft) thickness of the Equality Formation sand immediately beneath the refuse.

Two tills of the Wedron Formation occur below the Equality Formation. The upper till formation, the Yorkville Till Member, is a clayey, silty till from 1.5 to 7.5 m (5-25 ft) thick. This deposit is similar to the predominant surficial deposit present throughout northeastern Illinois. The Maiden fill Member, below the Yorkville Till Member, has interbedded sand lenses between two till units. The upper till is about 3.7 to 6.1 m (12-20 ft) of sandy silty till. It is discontinuous beneath the landfill site.

Interbedded lenses of sand below the upper till consist of 0.5-1.5 m (1.5-5 ft) of sand and fine gravel, and are also discontinuous at the site. The lower till is a silty till, approximately 6 m (20 ft) thick, at the base of the section.

Silurian-age fractured dolomite is the bedrock at the site. The dolomite is the major aquifer in the area.

SECTION 5

PUMPING EQUIPMENT

Four types of pumping methods were selected for collecting samples from the monitoring wells. These methods included a peristaltic pump (and/or diaphragm type pump), an air-lift system, a nitrogen-lift system, and a bailer. Most monitoring wells are commonly constructed using 3.81 or 5.08 cm (1-1/2 or 2 in.) diameter PVC pipe. These small diameters create severe limitations on the selection of a pumping apparatus.

In wells where pumping water lifts were within suction lift capabilities, a Masterflex 7545 variable speed drive unit equipped with a 7015 peristaltic pump head was used. When operated on 115 volts (a portable generator), it is capable of producing from about 50 to 1000 mL/min (0.013 to 0.264 gal/min).

For wells where pumping lifts were beyond suction lift capabilities, a diaphragm type pump modeled after the Middleburg pump was constructed and used. This type of pump is available commercially, but on a limited basis. The flow rate and lift capability from this type of pump is controlled by varying the frequency of alternately applied and released pressure on the diaphragm and by regulating the pressure at which it operates. The pump constructed for this project is 45.72 cm (18 in.) long, is 3.18 cm (1-1/4 in.) in diameter, and delivered water from 12.19 cm (40 ft) at a rate of 3500 mL/min (0.92 gal/min). The pump was not tested at greater depths but should be limited only by the operating pressure.

For the air-lift and nitrogen-lift pumping systems, an apparatus similar to that shown in Figure 2 was used. For some sampling runs, a 1.27 cm (1/2 in.) diameter rigid PVC discharge pipe and a 0.635 cm (1/4 in.) plastic airline were used. For others a 0.952 cm (3/8 in.) diameter flexible polyvinyl discharge line and 0.635 cm (1/4 in.) plastic airline were used. For all air-lift runs, a four-cylinder electric driven air compressor was used.

For the operation of the nitrogen-lift pumping mechanism, cylinders of compressed nitrogen gas were used to pressurize the identical apparatus used in the air-lift pumping experiments. A pressure regulator and flow-meter were used to control the pressure and flow rate to the gas line. Physical dimensions affecting the operation and efficiency of the air-lift or nitrogen-lift pumping mechanisms include: 1) the operating pressure should be 1 or 2 psi greater than the hydrostatic pressure at the pump intake; 2) the rate of air or nitrogen delivery to the system is dependent on the diameter of the discharge pipe; and 3) this type of system generally will not operate efficiently at a submergence of less than 1/3 of the total lift to be overcome.

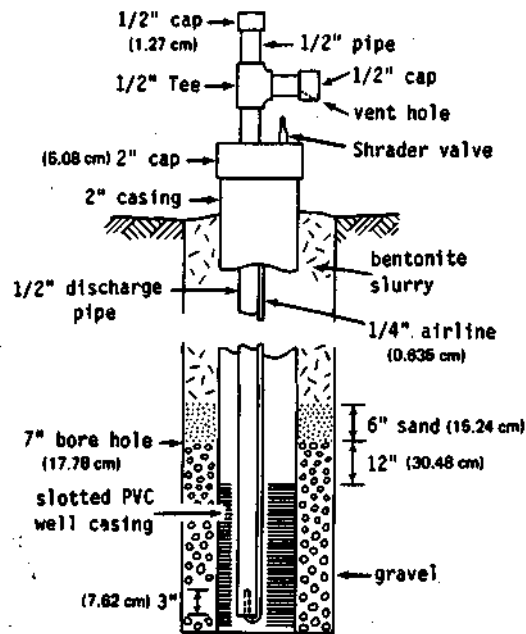

Figure 2. Typical well and air-lift pumping mechanism (after Walker, 1974)

For bailing, a 2.54 cm (1 in.) diameter stainless steel bailer, 0.914 m (36 in.) long, was constructed. The bailer retrieved a sample of about 300 mL (0.08 gal).

For purposes of comparison, the vertical point of sample collection from within the well for all pumping mechanisms was the mid-point of the well screen. The pump intakes for the peristaltic, air-lift, and nitrogen-lift systems were set in each well at the mid-point of the screen. When bailing, the bailer rope was marked such that the bottom of the bailer would be lowered to the same point in the well (the mid-point of the screen) during each successive bail.

Controlled pumping tests were conducted on the six wells to determine the hydraulic characteristics of the materials in which the wells were finished. Pumping tests were conducted using a peristaltic pump. The pump rates were determined by a graduated cylinder and stop watch. Water levels were measured with a steel tape.

SECTION 6

SAMPLE COLLECTION AND PREPARATION

Each of the six sites was sampled a maximum of once a month by one of the four pumping mechanisms. This sampling scheme was used to study the effects of the pumping mechanisms, well flushing, and filtration on sample composition. The frequency of sampling allowed ample time for the wells to recover from the pumping that had occurred during the previous sample collection.

Samples were taken from the initial water in storage, designated as the zero well volume, and at 1/2, 1, 1-1/2, 2, 4, 6, 8, and 10 well volume intervals. One well volume is defined as the amount of water occupying the well casing before pumping was initiated. The volumes of the samples collected were determined by the amount of water available per well volume and the amount needed for the analysis to be conducted. Measurements of pH, specific conductance, and alkalinity were made on unfiltered aliquots of each of the well volumes or partial well volumes that were sampled. These measurements were conducted immediately after the aliquots were collected to minimize opportunities for changes in chemical composition due to exposure with the atmosphere.

The sample aliquots were subdivided into three portions by filtering through either a 3.0 μm , 0.45 μm , or 0.22 μm pore size Millipore^R membrane. Satorius^R plastic filter holders fitted for 47 mm diameter filters were used with compressed nitrogen gas over pressure to speed filtration. Each filtered subsample was then further subdivided into samples for total organic carbon (TOC), cation, and anion analysis. All filtering was conducted in the field immediately after each sample was collected.

Samples for sulfate, chloride, ammonia, and nitrate determinations were stored on ice while in the field and later at 4°C in the laboratory. Aliquots for total organic carbon (TOC) were preserved by addition of a few drops of concentrated sulfuric acid, and the samples for cation analysis were acidified with nitric acid to a pH <1.5. Samples were acidified immediately after filtration. Detailed procedures used for sample preservation are given by the U.S. EPA (1979).

All samples were stored in linear polyethylene bottles that had been washed with dilute nitric acid and rinsed with dionized water. The preservation techniques and use of linear polyethylene bottles have been well documented in the literature, as stated previously, and no variations of any of these preservations procedures were attempted.

To study the effects of sample storage on sample integrity and to further study the effects of the pump systems on chemical composition, an additional sampling scheme was conducted. At sites 5-BRD and 6-DUP, large volume samples (4 L) were collected from the 0, 1, 2, 4, 6, 8, and 10th well volumes pumped with the peristaltic pump. A small aliquot of each of the collected samples was immediately filtered and preserved. After pumping ten well volumes, the pump was withdrawn from the well and replaced with the air-lift mechanism, and a second 4-L sample was taken using compressed air. Nitrogen gas was then substituted for the air and used to collect another 4-L sample. The air-nitrogen-lift mechanism was then removed from the well and a 4-L sample was collected using a bailer. On-site pH measurements were made on each of the unfiltered samples, after which small aliquots of each were filtered and preserved. The remaining large volume samples were returned to the laboratory unfiltered, without preservation. Samples were taken in the laboratory the same day as field sampling and every succeeding day for a period of 4 days. For this part of the project only the 0.45 μm pore size membranes were used for filtration.

SECTION 7

CHEMICAL ANALYTICAL METHODS

The Jarrell-Ash^R Atom Comp 975 inductively coupled argon plasma source direct reading emission spectrophotometer (ICP) was used for the determination of Al, As, B, Ca, Cd, Cr, Co, Fe, Mg, Mn, Pb, Se, and Zn. Table 1 lists the typical detection limits for the ICP used during this study. Na and K were determined by atomic absorption, while Cl^- , F^- , and pH were measured electrometrically using specific ion electrodes. Sulfate was determined turbidimetrically. Nitrate analysis was accomplished by the cadmium reduction method, and TOC (total organic carbon) was measured using an Oceanographic International 0524B total carbon system.

Field measurement of pH was conducted with an Orion^R 407A field model pH meter. Specific conductance (EC) was measured with a YSI^R model 33 S-C-T meter, and alkalinity was determined by titration to the methyl orange end point.

Table 1. Typical Detection Limits for ICP
(concentrations in mg/L)

Al	0.09
As	0.07
B	0.01
Ca	0.004
Cd	0.01
Cr	0.02
Co	0.01
Cu	0.01
Fe	0.05
Mg	0.01
Mn	0.005
Pb	0.03
Se	0.05
Zn	0.05

SECTION 8

FACTORS CONTROLLING GROUNDWATER QUALITY

Prior to studying the effects of pumping mechanisms and well flushing on groundwater quality, it would be instructive to briefly review the factors controlling groundwater quality. An understanding of these factors allows for a clearer definition of the mechanisms induced by sampling that are responsible for changes in chemical composition of groundwater samples.

Each of the six monitoring wells sampled during this project was situated either into or adjacent to areas being used for solid or liquid waste disposal. Thus, the water quality at the sites was influenced by the types of waste materials and the disposal methods used at the individual sites. A discussion of the transport mechanisms and mobility of contaminants in ground water at these sites is beyond the scope of this report. Such a discussion would require a detailed knowledge of the hydrogeology of each site, the disposal methodology, materials disposed, and detailed background data on water quality and atmospheric conditions. With this information, a mass balance analysis of mineral weathering, dissolution of the wastes, and chemical reactions responsible for the groundwater quality could be attempted. However, studying the factors influencing the in situ groundwater quality at the disposal sites was not the objective of this study. The objective of the project was to develop a methodology for the sampling of groundwater from monitoring wells at disposal sites that would produce samples representative of the water in the aquifer under study. Therefore, the subjects to be reviewed here are the factors that would induce changes in chemical composition of groundwater samples by sampling, not those that affect ground water quality in the aquifer. The discussion will be further limited to those mechanisms and reactions that affected samples collected at the six sites studied during this project.

Groundwater quality is primarily a function of the mineralogy of the medium through which the water flows, the residence time of the water within the medium, and the mixing of waters of different quality. Within an aquifer there are six major processes that may alter the chemical character of the groundwater. These are:

- 1) complex formation
- 2) acid-base reactions
- 3) oxidation-reduction processes
- 4) precipitation-dissolution reactions
- 5) adsorption-desorption reactions
- 6) microbial processes

All of these processes can be affected by the methods used to obtain a water sample from an aquifer, which may result in production of a sample that may not be representative of the water from the aquifer. Changes may occur when the groundwater is removed from the aquifer and exposed to atmospheric conditions where the temperature, pressure, O₂, and CO₂ content may be different from that in the aquifer. The degree of change in water quality will often depend upon the magnitude of difference between the groundwater and surface environments.

The basis for many acid-base reactions in groundwater is the availability of carbonate sources. To a large extent, the presence of carbon dioxide in water is the result of the decomposition of organic matter by bacteria. If rain water percolates down through surface organic matter, it may dissolve a significant quantity of CO₂. Carbon dioxide exhibits limited solubility. For the reaction

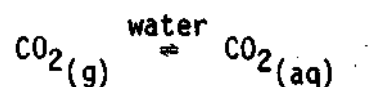

the equilibrium constant at 25°C is:

$$K = \frac{[\text{CO}_2(\text{aq})]}{P_{\text{CO}_2}} = 3.4 \times 10^{-2} \frac{\text{moles}}{\text{L} \times \text{atm}}$$

The carbonate system in water can be described by the following set of reactions:

Dissolution of CO₂ in H₂O:

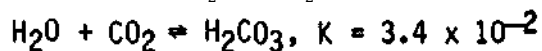

First Acid Dissociation:

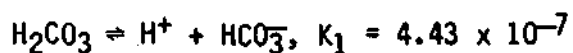

Second Acid Dissociation:

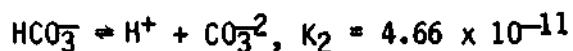

Given the equilibrium constants (K, K₁, and K₂), a distribution of species diagram for the carbon dioxide, bicarbonate ion, and carbonate ion system can be prepared with pH as the controlling variable. According to Figure 3, for most groundwaters the predominant species is HCO₃⁻.

The concentration of HCO₃⁻ may be enhanced in some groundwater systems by the dissolution of calcite by dissolved CO₂ in groundwater:

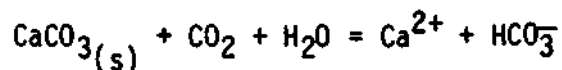

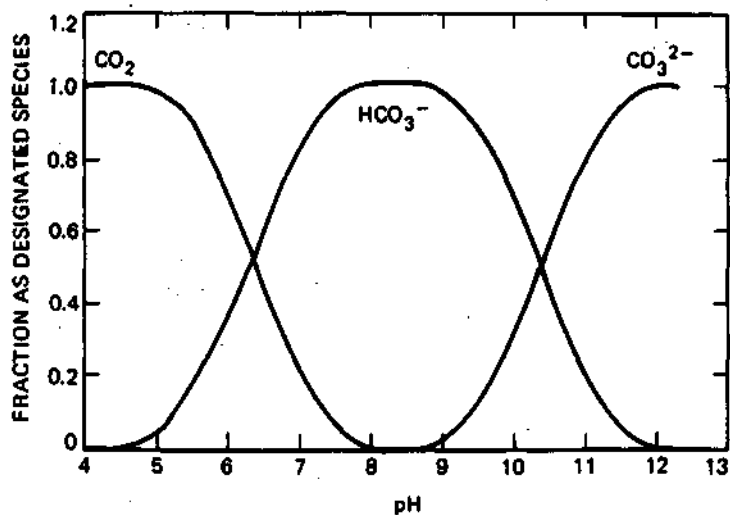
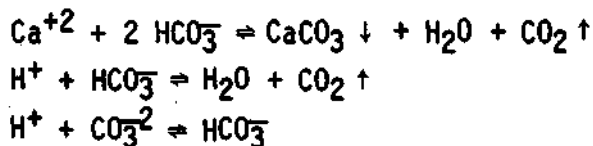

Figure 3. Distribution of species for the $\text{CO}_2\text{-HCO}_3^-\text{-CO}_3^{2-}$ system in water (Manahan, 1972)

An unstable condition is created when a groundwater sample, equilibrated with carbonate minerals, is exposed to the surface environment. The sample will de-gas or lose a quantity of CO_2 to the atmosphere. Since the partial pressure of atmospheric CO_2 is generally lower than that of groundwater, the sample will begin to equilibrate to atmospheric conditions. A study by Wallich (1977) revealed a similar condition where sample pH levels were elevated by the loss of CO_2 according to the following equations:



Thus, the loss of CO_2 from the system decreases the hydrogen ion activity and increases pH. In Wallich's (1977) study, pH increases were as great as 0.5 pH units. Interestingly, the loss of carbonate from the system was further suggested by the precipitation of CaCO_3 .

Oxidation-reduction reactions are also a major mechanism responsible for the collection of nonrepresentative aquifer water. Jackson and Inch (1980) reported a sequence of redox processes (Table 2) that would occur, according to thermodynamic calculations, in reduced groundwaters exposed to dissolved oxygen. This sequence represents such groundwater phenomena as the purification of leachate by oxygenated groundwaters, and the oxidation of spring waters. It also can represent oxidation reactions occurring in a groundwater sample upon exposure to atmospheric conditions. According to Stumm and Morgan (1970), the following redox processes should take place under these conditions:

- 1) oxidation of organics
- 2) oxidation of sulfide to sulfate
- 3) oxidation of ferrous iron and precipitation of $\text{Fe}(\text{OH})_3$
- 4) oxidation of ammonium ion to nitrate
- 5) oxidation of Mn and precipitation of MnO_2 or similar hydrous oxide

Table 2. Redox Processes in an Open System (Jackson and Inch, 1980, modified after Stumm and Morgan, 1970)

Reaction	Equation
(1) Aerobic respiration	$O_{2(g)} + CH_2O = CO_{2(g)} + H_2O$
(2) Sulfide oxidation	$O_{2(g)} + 1/2 HS^- = SO_4^{2-} + 1/2 H^+$
(3) Fe(II) oxidation	$O_{2(g)} + 4 Fe^{2+} + 10 H_2O = 4 Fe(OH)_3 + 8 H^+$
(4) Nitrification	$O_{2(g)} + 1/2 NH_4^+ = 1/2 NO_3^- + H^+ + 1/2 H_2O$
(5) Mn(II) oxidation	$O_{2(g)} + 2 Mn^{2+} + 2 H_2O = 2 MnO_{2(s)} + 4 H^+$

The occurrence and magnitude of these processes depend on the groundwater quality. Complex-ion formation may bind the Fe and Mn in the groundwaters in a nonoxidizable form. The exposure of the reduced water sample to surface atmospheric conditions would then have little if any effect on the Fe and Mn concentrations in solution.

The kinetics of Mn oxidation are considerably slower than those for Fe oxidation. It is possible to collect a water sample that is representative of the aquifer water with respect to one constituent (Mn) and not another (Fe), depending on how rapidly the sample is preserved after collection. Thus, the extent of error induced by redox processes when measuring aquifer water quality is constituent specific.

Precipitation of hydrous Fe and Mn oxides presents another problem to the sampler. It is well documented (Jenne, 1968) that hydrous Fe and Mn oxide precipitates and coatings on sediment are a control on the sorption from solution of many heavy metals, including Co, Ni, Cu, and Zn. Thus, precipitation of Fe and Mn may result in loss from solution of other constituents by adsorption or co-precipitation with hydrous oxides that were not directly subject to oxidation themselves.

There are many changes that can take place in a groundwater sample between collection and preservation. The above discussion has treated the principal mechanisms responsible for change in chemical composition as they are thought to have affected water samples collected during this project. Samples collected from monitoring wells at other sites may respond differently to the same processes depending on the chemical composition of the groundwater at each site.

SECTION 9

RESULTS

PUMP TEST ANALYSIS

Traditional analyses of pump test data usually use the equations derived by Theis (1935) and Jacob (1950). One of the basic assumptions made in deriving those equations is that all of the water pumped from a well during the pumping test comes from the aquifer and that none comes from storage within the well. Since this condition is not always fulfilled in practice, particularly for low yielding wells commonly used for monitoring wells, Theis' and Jacob's equations are somewhat inappropriate for describing the behavior of water levels during pumping for most monitoring wells.

Papadopoulos and Cooper (1967) presented an equation describing the discharge from a pumped well, which takes into account the volume of water removed from casing storage.

The drawdown (s) inside the well is expressed as

$$s = (6.875 Q/T) F(u, \alpha) \quad (1)$$

where

s = drawdown in the well after a given pumping time in meters

Q = pumping rate in L/sec

T = transmissivity in m²/day

F(u,) = well function as defined by Papadopoulos and Cooper (1967)

Table 3 presents values of the function F(u,0) as defined by Papadopoulos and Cooper. The values of u for each time increment can be calculated using equation (2).

$$u = \frac{360r^2S}{Tt} \quad (2)$$

where

r = radius of the well in meters

S = coefficient of storage

T = transmissivity in m²/day

t = time in minutes

The value of 0 is synonymous with the coefficient of storage (S).

Table 3. Values of the Function $F(\mu,)$

u	$\alpha=10^{-1}$	$\alpha=10^{-2}$	$\alpha=10^{-3}$	$\alpha=10^{-4}$	$\alpha=10^{-5}$
10	9.755×10^{-3}	9.976×10^{-4}	9.998×10^{-5}	1.000×10^{-5}	1.000×10^{-6}
1	9.192×10^{-2}	9.914×10^{-3}	9.991×10^{-4}	1.000×10^{-4}	1.000×10^{-5}
5×10^{-1}	1.767×10^{-1}	1.974×10^{-2}	1.997×10^{-3}	2.000	2.000
2	4.062	4.800	4.989	4.999	5.000
1	7.336	9.665	9.966	9.997	1.000×10^{-4}
5×10^{-2}	1.260×10^0	1.896×10^{-1}	1.989×10^{-2}	1.999×10^{-3}	2.000
2	2.303	4.529	4.949	4.995	5.000
1	3.276	8.520	9.834	9.984	1.000×10^{-3}
5×10^{-3}	4.255	1.540×10^0	1.945×10^{-1}	1.994×10^{-2}	2.000
2	5.420	3.043	4.725	4.972	4.998
1	6.212	4.545	9.069	9.901	9.992
5×10^{-4}	6.960	6.031	1.688×10^0	1.965×10^{-1}	1.997×10^{-2}
2	7.866	7.557	3.523	4.814	4.982
1	8.572	8.443	5.526	9.349	9.932
5×10^{-5}	9.318	9.229	7.631	1.768×10^0	1.975×10^{-1}
2	1.024×10^1	1.020×10^1	9.676	3.828	4.861
1	1.093	1.087	1.068×10^1	6.245	9.493
5×10^{-6}	1.163	1.162	1.150	8.991	1.817×10^0
2	1.255	1.254	1.249	1.174×10^1	4.033
1	1.324	1.324	1.321	1.291	6.779
5×10^{-7}	1.393	1.393	1.392	1.378	1.013×10^1
2	1.485	1.485	1.484	1.479	1.371
1	1.554	1.554	1.554	1.551	1.513
5×10^{-8}	1.623	1.623	1.623	1.662	1.605
2	1.705	1.705	1.705	1.714	1.708
1	1.784	1.784	1.784	1.784	1.781
5×10^{-9}	1.854	1.854	1.854	1.854	1.851
2	1.945	1.945	1.945	1.945	1.940
1	2.015	2.015	2.015	2.015	2.015

Drawdown values calculated from equation (1) differ significantly from those based on Theis' and Jacob's equations during the early portion of the pumping test when a relatively high percentage of the discharge comes from casing storage. During the later stages of the pumping test, when only a negligible quantity of water is obtained from casing storage, the equations produce equivalent results. If the effects of casing storage are not taken into account, it is possible with many monitoring wells to misinterpret the data and assume an erroneous T (transmissivity) value based on early drawdown data.

In order to avoid misinterpretation of the data, it is necessary to have some method for determining when the effect of casing storage becomes negligible. To accomplish this, Papadopulos and Cooper developed equation (3) for calculating the time at which the effects of casing storage are no longer significant.

$$t_c = \frac{1440(r_c^2 - r_p^2)}{T} \quad (3)$$

where

t_c = time in minutes after which the effects of casing storage can be ignored (assuming a 1 percent error in drawdown values)

r_c = radius of well casing (inside dimension) in meters

r_p = radius of pump column or discharge pipe (outside dimension) in meters

T = transmissivity in m^2/day

The above equation requires prior knowledge of a transmissivity value and assumes a 100 percent efficient well. Schafer (1978) suggests using the following equation to estimate the t_c :

$$t_c = \frac{1440(d_c^2 - d_p^2)}{Q/s} \quad (4)$$

where

t_c = time in minutes when casing storage effects become negligible

d_c = inside diameter of well casing in meters

d_p = outside diameter of pump column in meters

Q/s = specific capacity of the well in m^2/day of drawdown at t_c

Pump test data for sites 1-SDV, 2-ELG, 3-FLR, 4-TYL, and 6-DUP were analyzed using equations (1), (2), and (4) described above. At all of the sites analyzed, the nonpumping water levels were significantly above the tops of the aquifers tapped, suggesting artesian conditions. A storage coefficient (S) of 0.0001 was chosen and used in all analyses. The drawdown values as described by the Papadopulos and Cooper equation are relatively insensitive to changes in storage coefficient. The storage coefficient value selected, therefore, should have little effect on the aquifer properties determined for each site.

Site 1-SDV

A pumping test was conducted on the site 1-SDV well on January 11, 1979. The well at site 1-SDV was pumped with a Jabsco self-priming pump at rates varying from 1759 mL/min to 1000 mL/min for a period of 15 minutes before the pump broke suction. Water level recovery data were collected for a period of 30 minutes after pumping stopped. Since the length of time of pumping was not long, the recovery data were used to determine an aquifer transmissivity of about 1.24 m²/day (100 gpd/ft). Figure 4 illustrates the general agreement between adjusted pump test results and the theoretical drawdown curve.

The Papadopoulos and Cooper method of analyses can be used to develop theoretical drawdown curves, but more importantly for collection of monitoring well samples, the amount of water coming from the aquifer can be calculated for each time increment. These amounts as percentages of total pumpage, $(Q_a/Q_t) \times 100$, are presented in Figure 5 for a pumping rate of 500 mL/min for all six sites. Based on these calculations it appears that a pumping rate of 500 mL/min for the site 1-SDV well should produce water samples containing approximately 90 percent aquifer water in about 10 minutes. This conclusion is based on the assumption that the pump intake is located in the screened portion of the well near the bottom so that mixing of aquifer and casing water will be minimal. The net effect is to "isolate" the stagnant water in the well casing.

Site 2-ELG

A pumping test was conducted on the site 2-ELG well on January 17, 1979. The well at site 2-ELG was pumped with the peristaltic pump at rates varying from 725 to 775 mL/min for a period of 2 hours. Recovery measurements were taken for 30 minutes after pumping stopped.

With the analysis method developed by Papadopoulos and Cooper, an aquifer transmissivity of about 0.56 m²/day (45 gpd/ft) was calculated. Figure 6 illustrates the general agreement between the early pump test results and the theoretical drawdown curve.

Calculations of the percent of aquifer water pumped at 500 mL/min indicate that this well also will deliver approximately 90 percent aquifer water in about 10 minutes (Figure 5). Because of the small diameter of the well and the low yield potential of the aquifer at the start of pumping, a smaller percentage of aquifer water is obtained than for the site 1-SDV well.

Site 3-FLR

A pump test was conducted on the site 3-FLR well on August 9, 1979. The well at site 3-FLR was pumped with the peristaltic pump at rates of 425 to 400 mL/min for a period of 90 minutes. Water level recovery measurements were made for a period of 30 minutes after pumping stopped.

The method of analysis developed by Papadopoulos and Cooper was used and an aquifer transmissivity of about 1.55 m²/day (125 gpd/ft) was calculated.

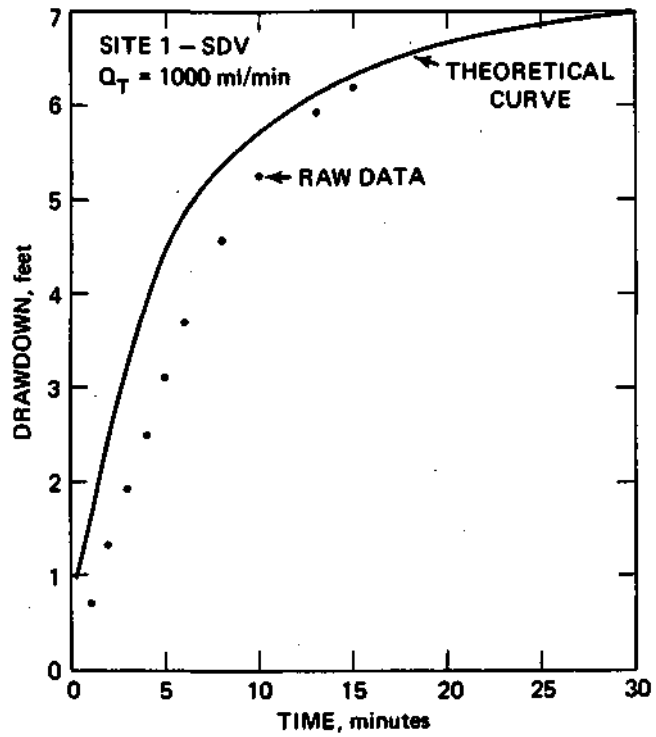

Figure 4. Site 1-SDV: time-drawdown data and theoretical curve

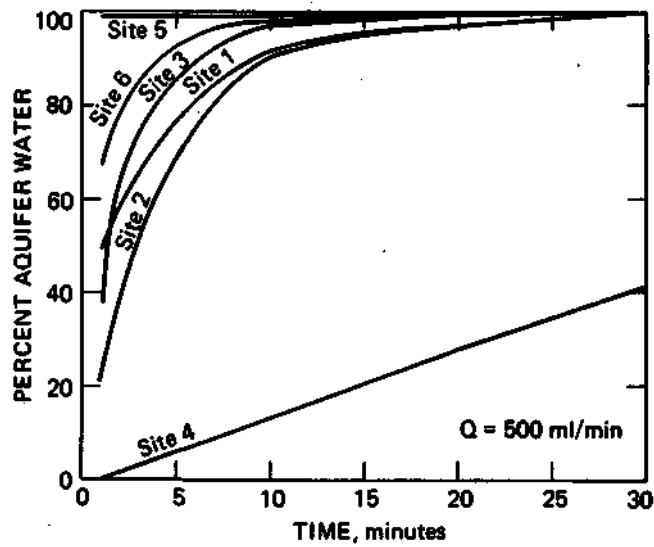

Figure 5. Aquifer yield curves for all six sites

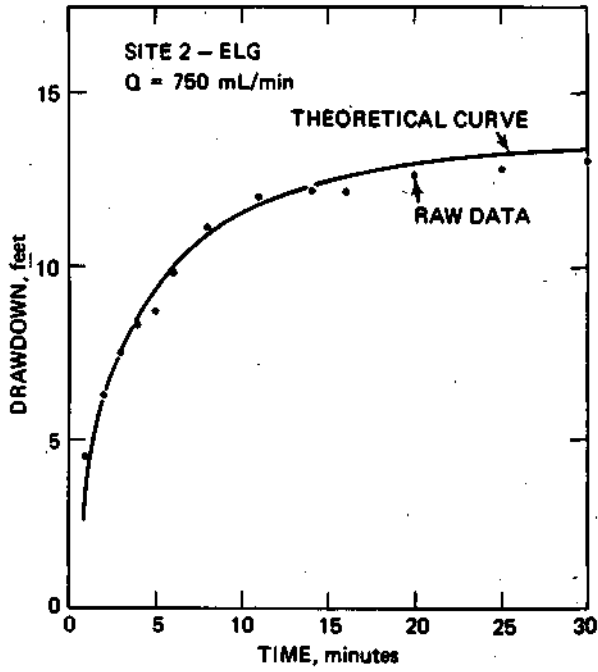

Figure 6. Site 2-ELG: time-drawdown data and theoretical curve

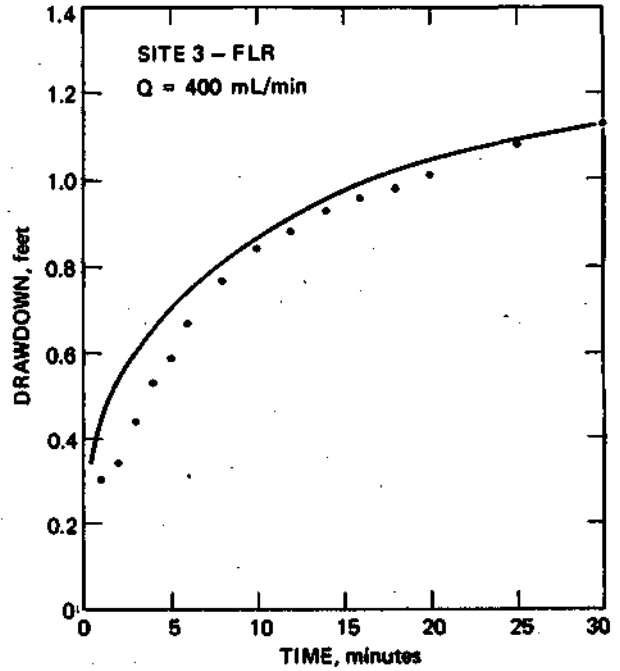

Figure 7. Site 3-FLR: time-drawdown data and theoretical curve

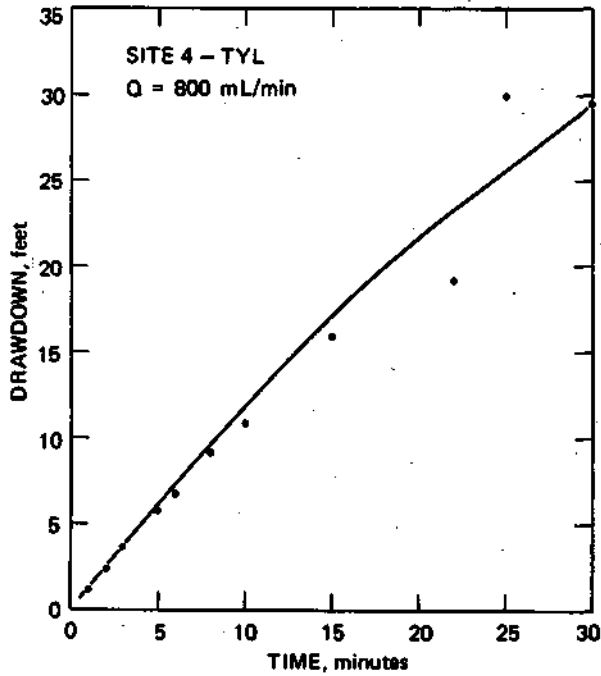

Figure 8. Site 4-TYL: time-drawdown data and theoretical curve

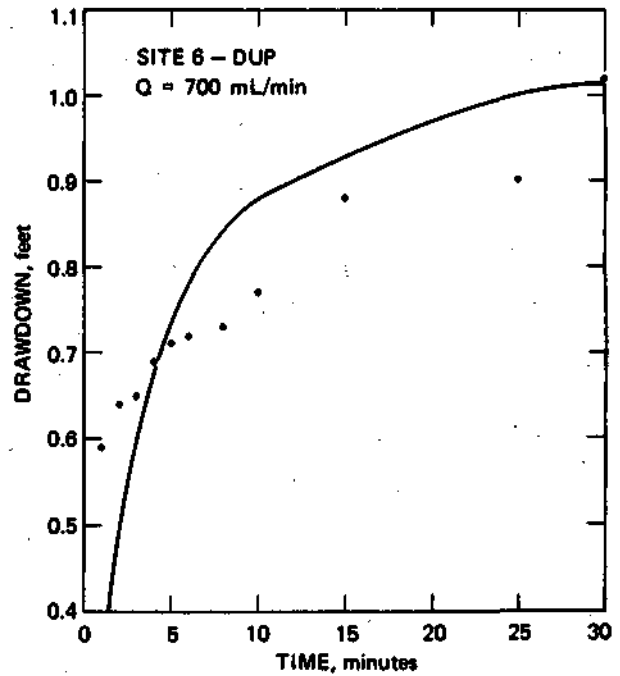

Figure 9. Site 6-DUP: time-drawdown data and theoretical curve

Figure 7 illustrates the general agreement between the early pump test results and the theoretical drawdown curve.

The aquifer yield curves presented in Figure 5 suggest that when pumped at 500 mL/min this well will produce about 90 percent aquifer water in about 5 minutes.

Site 4-TYL

A pumping test was conducted on the site 4-TYL well on November 18, 1978. The monitoring well at site 4-TYL was pumped with the peristaltic pump at rates from 715 to 600 mL/min for a period of 20 minutes, and water level recovery measurements were made for a period of 30 minutes after pumping stopped.

On the basis of the results of the recovery data, an aquifer transmissivity of about $0.05 \text{ m}^2/\text{day}$ (4 gpd/ft) was determined. Figure 8 illustrates the general agreement between the early pump test results and the theoretical drawdown curve.

Figure 5 illustrates the percent aquifer water pumped with time at 500 mL/min. Because of the extremely low transmissivity value at this site, it is unlikely that a significant percentage of aquifer water could be obtained at even lower pumping rates. At pumping rates of 50 and 100 mL/min, calculations show that only 42 percent aquifer water is pumped after 30 minutes. For this reason it may be desirable and more practical to simply pump the well dry, allow it to recover, and then collect the sample. Results of sampling using this procedure are presented later in this report for wells at sites 2-ELG and 4-TYL.

Site 5-BRD

A pump test was attempted on the site 5-BRD well on August 22, 1979. The well at site 5-BRD was pumped with the peristaltic pump at rates from 750 to 650 mL/min for a period of 2 hours. The total water level drawdown for the period of pumping was only 5.18 cm (0.17 ft). The data obtained from this test proved to be of little value in determining aquifer properties except to point out that the transmissivities were very high relative to the other sites.

Because of the small diameter of the well and the high water-yielding character of the aquifer, a pump of adequate capacity that would fit into the well and still permit measurement of water levels could not be found. Regional data on larger production wells tapping the same aquifer in the same area indicate a range of aquifer transmissivities from about 3,700 to 9,900 m^2/day (300,000 to 800,000 gpd/ft).

Based on the inability to pump the well at rates sufficient to create significantly measurable drawdown, it can be assumed that essentially all water pumped during the sampling runs to be discussed later was "aquifer water" and not water from storage within the well casing (Figure 5).

Site 6-DUP

A pumping test was conducted on the site 6-DUP well on July 24, 1979. The well at site 6-DUP was also pumped with a peristaltic pump at rates from 765 to 620 mL/min for a period of 2 hours. Recovery measurements were taken for 10 minutes after pumping stopped.

An aquifer transmissivity of 2.48 m²/day (200 gpd/ft) was determined. Figure 9 shows the general agreement between the early pump test results and the calculated theoretical drawdown curve. According to Figure 5, this well should yield about 92 percent aquifer water in about 5 minutes when pumped at 500 mL/min.

On the basis of the results of the pumping tests at five of the sites, three basic principles have been substantiated: (1) constant rate pumping tests can be performed on monitoring wells and the results analyzed to determine aquifer properties; (2) the proper applications of the equations developed by Papadopulos and Cooper allow for straightforward determination of realistic transmissivity values for the water strata being sampled by the monitoring well; and (3) once the transmissivity of the aquifer tapped by a monitoring well has been determined, the percent of water coming from the aquifer and that from storage can be determined as a function of pumping time. Figure 10 illustrates the percent of water pumped that is coming from this aquifer at a pumping rate of 500 mL/min. As expected from the results of the pump tests presented in Figure 5, the higher percentages of aquifer water are derived from the higher yielding wells (larger T values). Once a T value of 62.0 m²/day (5000 gpd/ft) is encountered, larger values of T make little or no difference at a pumping rate of 500 mL/min. Thus, if the yield capability of the well is sufficiently large (T > 5000 gpd/ft), then the effects of water from storage become negligible for 5.08 cm (2 in.) diameter wells and can be ignored when establishing a sampling protocol at this pumping rate.

Additional calculations illustrate the effect of the diameter of the well on the percent of aquifer water removed at a constant pumping rate and transmissivity (see Figure 11). For a T of 2.48 m²/day (200 gpd/ft) and a pumping rate of 500 mL/min, well diameters larger than 5.08 cm (2 in.) have a significant effect on the percent of aquifer water pumped, particularly during the very early stages of pumping. Results from analyses of pump test data provide the basic hydrologic information needed to permit a better understanding of the changes in chemical quality of water that are likely to occur as a function of pumping time as the sample is pumped from a monitoring well.

During the course of conducting pumping tests on monitoring wells, various problems can be encountered. The following are suggestions to avoid those potential problems:

- 1) During the course of a pumping test the water levels drop and the yield capability of the peristaltic pump also declines. To compensate for declining pumping rates (or to maintain a constant pumping rate) it may be necessary to use a variable speed peristaltic pump and a slower overall pumping rate. As the water levels drop, the speed of the pump can be increased to maintain a relatively constant

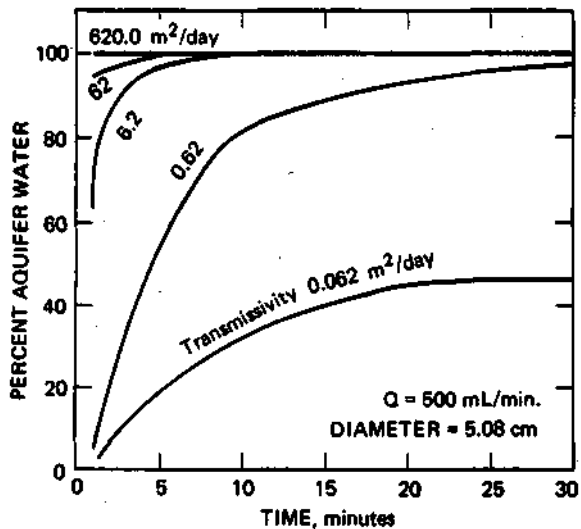

Figure 10. Percent of aquifer water versus time for different transmissivities

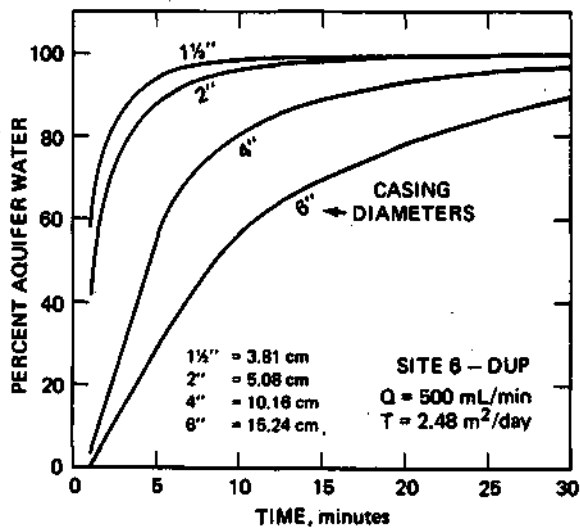

Figure 11. Percent of aquifer water versus time for different well casing diameters

pumping rate. The selection of a smaller pumping rate will probably be dictated by the anticipated total final drawdown or water level and the pump yield capacity at that particular pumping lift.

- 2) For low yielding wells it may be very difficult to maintain a constant pumping rate for a period of time adequate to provide data suitable for analyses. Pumping rates less than 100 mL/min for periods up to 2 or 3 hours may be necessary.
- 3) For very high yielding wells the peristaltic pump may not be capable of pumping at rates sufficient to induce enough drawdown to permit meaningful analyses. The use of the diaphragm type Middleburg pump with higher pumping rates may be helpful.

If pumping tests on monitoring wells are conducted correctly, it is felt that they provide more useful and valid data than those obtained from slug tests.

EFFECTS OF PUMPING MECHANISMS ON CHEMICAL COMPOSITION

As noted earlier, each of the six study sites was sampled using a peristaltic, air-lift, nitrogen-lift, and bailing mechanism. The sites were visited at one-month intervals to simulate monthly sampling as required by many regulatory agencies. For the purpose of discussing the effects of pumping mechanisms on sample chemistry, only data for samples filtered through 0.45 μm pore size membranes are presented.

Probably the single most important parameter affecting the chemical composition of groundwater is pH. Therefore, anything that alters the pH of the groundwater samples is likely to alter the groundwater composition. On-site pH measurements at all six sites using the four pumping mechanisms were analyzed. The data illustrate two possible effects of the type of pumping mechanism on chemical composition of samples. For comparative purposes, the averages of the pH values for the sixth, eighth, and tenth well volumes collected at each site by each of the four pump mechanisms are listed in Table 4. The pH values for the samples collected with the peristaltic pump and the bailer are lower by as much as 1.1 pH unit than the pH values for those samples taken with the air- and nitrogen-lift systems.

The size of the discharge pipe used with the air- and nitrogen-lift systems when collecting samples also affects their pH. Samples collected with either the air- or nitrogen-lift systems using a 0.952 cm (3/8 in.) diameter discharge pipe possess lower pH's than samples taken by either pump system when using a 1.27 cm (1/2 in.) diameter discharge pipe.

The increased pH values of samples collected with these pump systems are a result of bubbles of air or nitrogen rising through the water in the discharge pipe and stripping dissolved CO_2 from the water. The smaller changes in pH noted in the samples collected using the 0.952 cm (3/8 in.) discharge pipe occurred because less air or nitrogen was needed to pump the same quantity of water than with the 1.27 cm (1/2 in.) discharge pipe.

Table 4. Average pH Values for the Sixth, Eighth, and Tenth Well Volumes Collected at Each Site by Each Pump Mechanism

Site	Pump System			
	peristaltic	air	N ₂	bailer
1-SDV	4.5	5.4	5.3	5.2
2-ELG	7.0	8.0 ²	8.1 ²	ND ³
3-FLR	7.1	8.2 ²	7.6 ¹	7.3
4-TYL	7.2	8.2 ²	7.8 ¹	7.0
5-BRD	6.8	7.6 ¹	7.5 ¹	6.8
6-DUP	7.1	7.8 ¹	7.6 ¹	7.0

¹ 0.952 cm (3/8") id inlet line

² 1.27 cm (1/2") id inlet line

³ Not Determined

The gas-to-water ratios for the samples collected using the 0.952 cm (3/8 in.) diameter pipe varied from about 3.4 to 9.5, with the higher ratios generally resulting in larger pH changes. The gas-to-water ratios for the samples collected using the 1.27 cm (1/2 in.) diameter pipe were much higher (30 to 40) and appear to have effectively stripped the samples of most of their excess dissolved CO₂, resulting in pH values of 8.2 to 8.3. This can be compared with pH values of 6.9 to 7.0 when the peristaltic pump was used to collect samples.

Data from samples collected at site 5-BRD using an air-lift pumping mechanism dramatically illustrate the effect of discharge pipe size on pH. During the first stage of pumping (volumes 0 through 2), a 1.27 cm (1/2 in.) discharge pipe was used. To increase the pumping rate, the 1.27 cm (1/2 in.) pipe was withdrawn and a 0.952 cm (3/8 in.) pipe inserted between well volumes 2 and 4. The pH immediately dropped from 8.2 to 7.5, confirming the important effect of the gas-to-water ratios on the pH of water samples collected with gas-lift devices.

With the exception of site 1-SDV, the pH of samples collected with the peristaltic pump and bailer were similar. During the period between sampling at site 1-SDV with the nitrogen-lift system and with the bailer, the scrubber waste disposal pond had drained completely as it was no longer being used for disposal. Therefore, the hydrogeology of the site and the source of low pH water had been altered, making interpretation of the bailer data difficult.

It was not possible to make direct interpretation of the bailer data for site 1-SDV shown in table 4 to that collected by the other mechanisms.

Of the 20 chemical constituents and parameters measured, only pH, Fe, and Zn were found to be affected by the type of pump mechanism used to collect the samples. There were no obvious effects of any of the four pump mechanisms on the concentrations of alkalinity, Ca, Cl^- , F^- , Mg, Mn, Na, specific conductance, or TOC in the samples. Only in the site 1-SDV samples were there sufficient concentrations of Al, B, Cd, Cr, Ca, and Pb to assess the effects of the pump mechanisms. The overall variability of the water composition at site 1-SDV and the high concentrations of Zn (=25,000 mg/L) and Ca (2,000 mg/L) resulted in both chemical and physical interferences to the analytical procedures being used. Thus an evaluation of the effects of the pump mechanisms on Al, B, Cd, Cr, Cu, and Pb was not possible. It is suspected, however, that some if not all of these constituents will have their concentrations affected by the pump mechanism used for sample collection and their responses will be similar to that displayed by Fe and Zn.

For all of the sites where detectable Fe concentrations were found (sites 2-ELG, 5-BRD, and 6-DUP), the highest concentrations were in the samples collected with a peristaltic pump or bailer, followed by the samples taken with a nitrogen-lift. Only trace dissolved Fe concentrations were detected in any of the samples collected with the air-lift mechanism.

Figure 12 is a plot of the Fe concentrations in samples from site 5-BRD and clearly illustrates the effect of the pumping mechanisms on Fe content. Soluble Fe concentrations in the initial (zero) well volume taken by the peristaltic pump, bailer, and nitrogen-lift were 14.6, 17.4, and 22.8 mg/L, respectively. The dissolved Fe concentration in the zero well volume taken with the air-lift was 0.66 mg/L. The indication is that the use of an air-lift pumping mechanism results in partial removal of the available Fe from solution, probably by oxidation and/or a rise in pH with subsequent precipitation. The soluble Fe data plotted for the samples taken with the other mechanisms show a decline in concentration until the fourth well volume had been removed. The samples collected with the peristaltic pump and bailer maintained relatively similar Fe concentrations throughout the series. Although the samples taken with the nitrogen-lift exhibit an Fe-concentration well-volume curve similar to that of the bailed and mechanically pumped samples, the values are considerably lower. This lower concentration of Fe was felt to represent partial oxidation of the Fe by oxygen contamination in the compressed nitrogen gas, and/or precipitation due to the increase in pH brought about by the stripping of CO_2 by the nitrogen gas.

Figures 13 and 14 are plots of dissolved Fe versus volumes pumped for sites 2-ELG and 6-DUP. Again, the bailed and peristaltic pumped samples for both sites follow very similar trends. For site 2-ELG (Figure 13) the soluble Fe concentrations remain relatively constant, and for site 6-DUP (Figure 14) the values decrease during pumping of the first three to four well volumes, after which the concentrations stabilize. The differences in the dissolved Fe concentrations between the samples collected with the peristaltic pump and the bailer at each site may represent seasonal variations in the groundwater quality. The samples collected using nitrogen- and air-lift pumping mechanisms

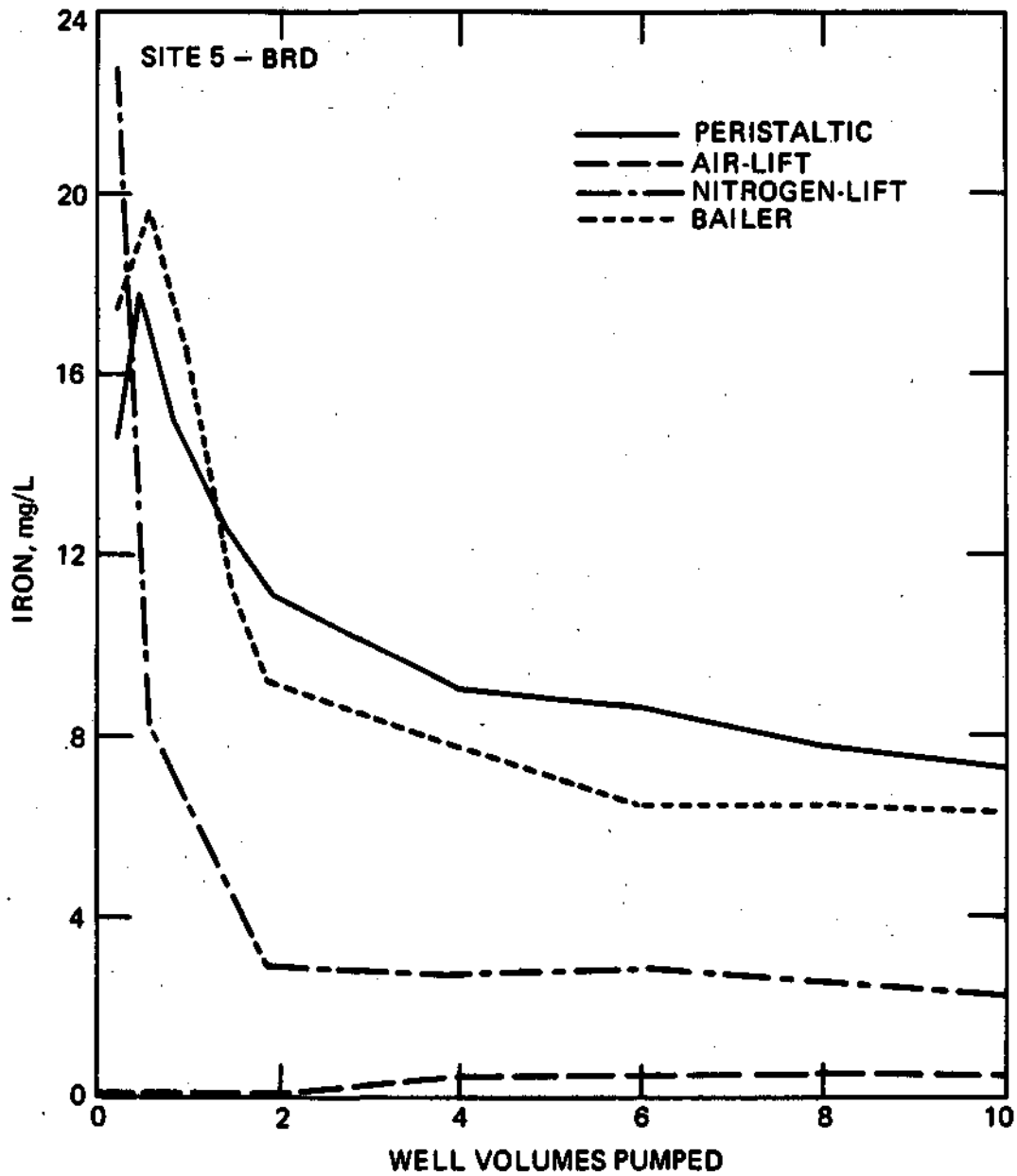

Figure 12. Effects of pumping mechanism on iron concentrations at site 5-BRD as a function of well volumes pumped

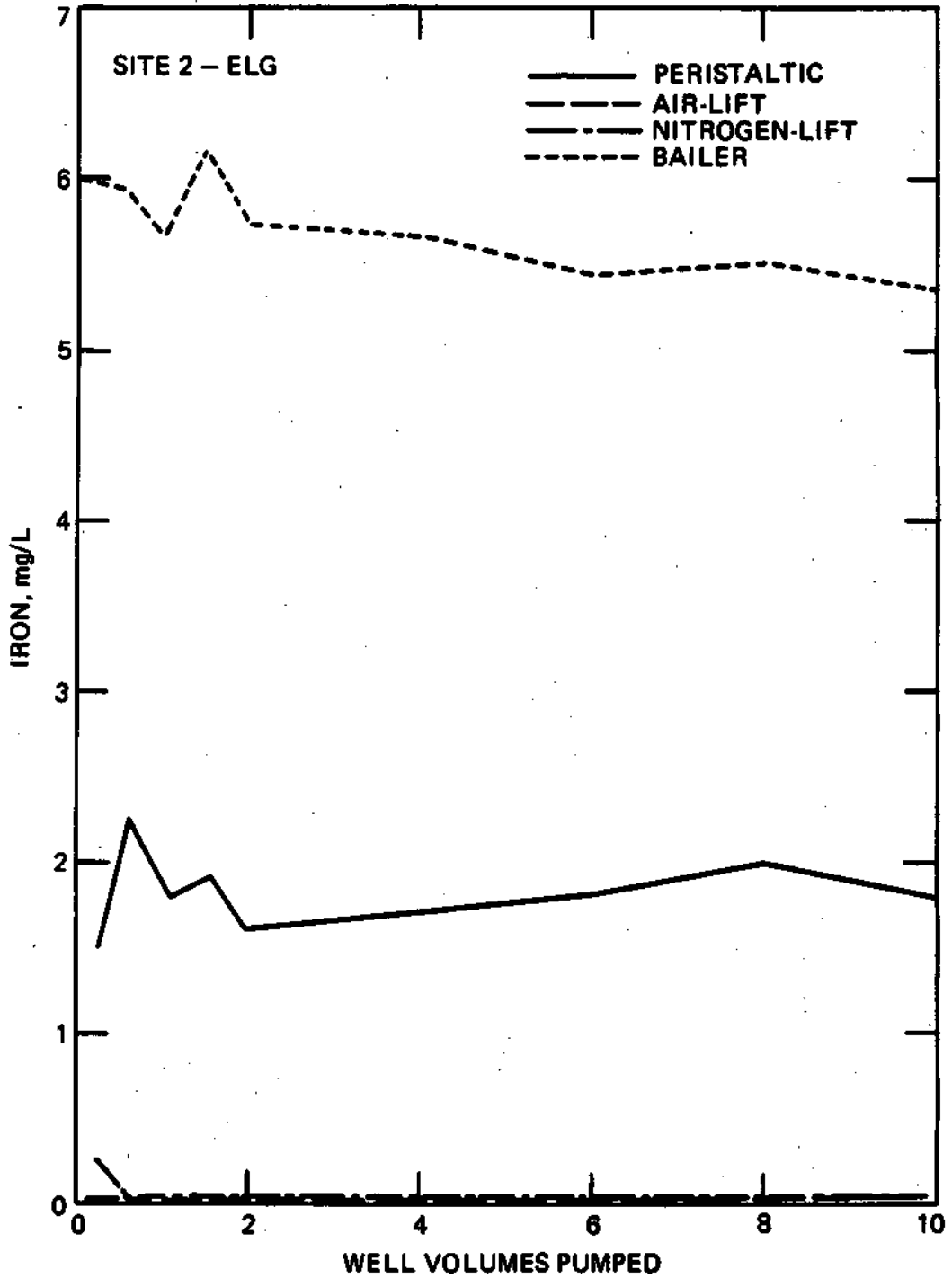

Figure 13. Effects of pumping mechanism on iron concentrations at site 2-ELG as a function of well volumes pumped

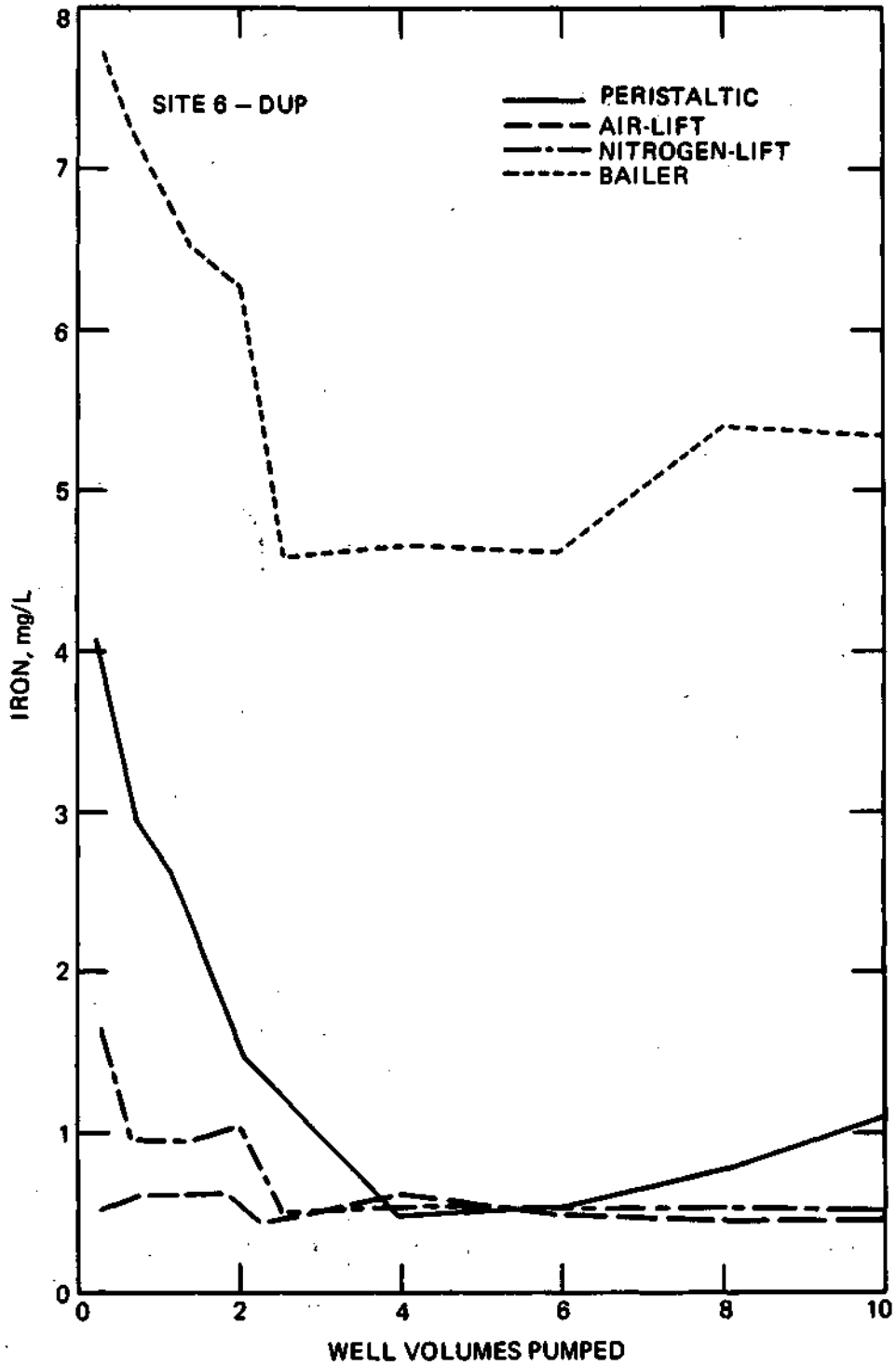

Figure 14. Effects of pumping mechanism on iron concentrations at site 6-DUP as a function of well volumes pumped

for site 2-ELG show only trace levels of dissolved Fe present and are considered to be a response of the samples to oxidation and changes in pH.

At site 6-DUP the soluble Fe concentrations in the samples taken with an air-lift mechanism remain almost constant through the ten well volumes (approximately 0.60 mg/L). The initial Fe concentrations in the samples collected with the mechanical and nitrogen-lift mechanisms were 4.0 and 1.7 mg/L, respectively. However, after pumping four well volumes using the three mechanisms, the resultant dissolved Fe concentrations in the samples were nearly identical. This would indicate that the groundwater in the aquifer (volumes four through ten) possessed a lower level (approximately 0.60 mg/L) of Fe than the storage water in the well casing and that the Fe is in a form not readily affected by the introduction of air or nitrogen into the system.

The sampling routine, using all four pump mechanisms on one date, was conducted to verify that the changes in pH, Fe, and Zn concentrations were due to the pump used and not to seasonal variations over the initial four-month sampling period. Table 5 lists the results of the sample collections at sites 5-BRD and 6-DUP, where all four pumping mechanisms were used on the same day after ten well volumes had been pumped with the peristaltic pump. The order of pumping mechanisms listed in the tables was the order in which they were used. Again, the pH values of the samples taken with the peristaltic pump and bailer are as much as 1.0 pH unit less than those samples taken with the air- and nitrogen-lifts. Table 5 also shows that the Fe concentrations for both sites and the Zn concentrations for site 5-BRD were affected by the choice of pumping system used to collect the samples. The choice of pump systems did not affect the concentrations of Ca, K, Mg, and Na in any consistent way. The loss of Fe from solution is most probably due to the precipitation of hydrous Fe oxides. Adsorption of Zn onto the Fe precipitates is presumed to be responsible for the loss of Zn. At both sites, the dissolved Fe concentrations found in the bailed samples were higher than in the samples taken with the peristaltic pump. This was believed to be a result of precipitated iron from the air- and nitrogen-lift pumping sequences being taken back into solution by the lower pH water entering the well from the aquifer and subsequently being collected with the bailer.

On the basis of the results of this portion of the study, the peristaltic pump and bailer appear to be the best types of sampling mechanisms to minimize chemical changes in water samples. This recommendation should be considered particularly when sampling for pH sensitive or volatile chemical parameters. The air- and nitrogen-lift systems are not recommended except in cases where pH insensitive and non-volatile species are to be measured in the samples.

For wells with water levels within suction lift capabilities, a peristaltic pump can be used. For wells with water levels below suction lift capabilities (about 5.2 m or 17 ft), the submersible diaphragm type of pump is recommended when the air- and nitrogen-lift systems are precluded due to the presence of sensitive chemical constituents. If the use of one of these types of pumps is not practical, a bailer is the next best choice. However, when collecting a water sample with a bailer, certain procedures need to be followed. The following is a partial listing of procedures which will aid in collecting representative samples with a bailer:

Table 5. Analysis of Samples from Sites 5-BRD and 6-DUP Collected by Four Pumping Mechanisms Immediately after Flushing Ten Well Volumes (Concentrations in mg/L)

Site 5-BRD

Sequence	Pumping Mechanism	pH	Ca	Fe	K	Mg	Na	Zn
1	Peristaltic	6.7	111	11.6	ND*	44.6	186	0.18
2	Nitrogen-lift	7.7	106	3.7	ND*	44.0	183	0.03
3	Air-lift	7.5	105	0.7	ND*	43.6	182	0.03
4	Bailer	6.8	105	13.5	ND*	42.2	179	0.96

Site 6-DUP

Sequence	Pumping Mechanism	pH	Ca	Fe	K	Mg	Na	Zn
1	Peristaltic	6.8	32.5	5.74	189	94.2	215	ND*
2	Nitrogen-lift	7.8	36.1	1.79	202	111	239	ND*
3	Air-lift	7.8	37.1	.57	199	115	247	ND*
4	Bailer	6.8	42.3	7.42	193	114	235	ND*

*ND - not detectable

- 1) The bailer should be constructed of a noncontaminating material.
- 2) A pass-through type flapper valve should be used to minimize disturbance as the bailer is lowered through the water column.
- 3) The bailer should be lowered to the same depth (the top of the well screen) every time to create the same effect as pumping with a peristaltic pump.
- 4) Bailing should be timed to approach a constant pumping rate and should continue until the appropriate well volumes are removed prior to collecting the sample.
- 5) The rope used to operate the bailer should be of a noncontaminating material and should be held off the ground during the bailing process.
- 6) The bailer and rope should be thoroughly cleaned before use in each well.

EFFECTS OF WELL FLUSHING ON CHEMICAL COMPOSITION

One recommended procedure for the collection of representative ground-water samples from monitoring wells is to flush the monitoring well to remove the stagnant water held in storage in the well casing, or to pump until a high percentage of aquifer water is being received. Storage water is defined as the water that does not come into contact with the flowing groundwater. Because of the existence of site-specific variables of geology, hydrology, transmissivity values, and chemistry between waste disposal sites, the extent of well flushing required will be different for each well. As demonstrated in Figures 5 and 10, a specific volume of water pumped from one monitoring well before sample collection may be sufficient to produce a representative sample of the aquifer, but at another site the same volume may be insufficient or perhaps may result in overpumping. Over-pumping may introduce groundwater from a distant source that could dilute or concentrate certain constituents and result in erratic or misleading data.

To assess the phenomenon of well flushing, the concentrations of the major constituents in the groundwater at each of the six sites, were plotted versus the well volumes pumped by the peristaltic pump (Figures 15 through 20). Due to the differences in chemistry and hydrology between the sites, it was instructive to plot the data for each site individually with the exception of sites 3-FLR and 4-TYL, which were chemically similar. Unless otherwise noted, all the data discussed were from samples prepared by filtration through a 0.45 μm pore size membrane.

Determinations of SO_4^{2-} , Cl^- , and F^- were conducted. However, only the Cl^- data for a few of the sites will be discussed. Overall, these constituents were not present in the samples in concentrations exceeding the detection limits of the analytical procedures used.

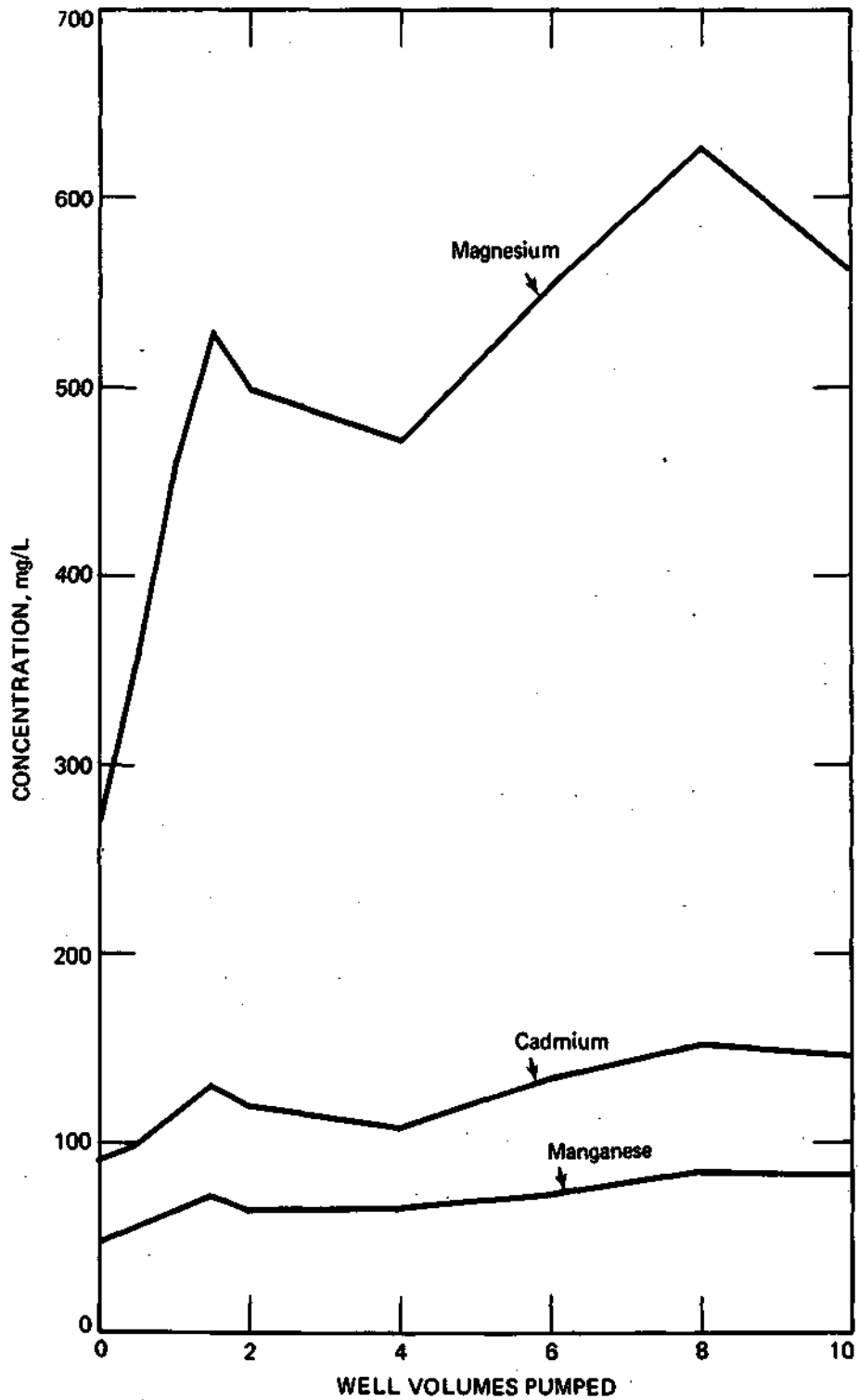

Figure 15. Site 1-SDV: magnesium, cadmium, and manganese concentrations versus volumes pumped (peristaltic pump)

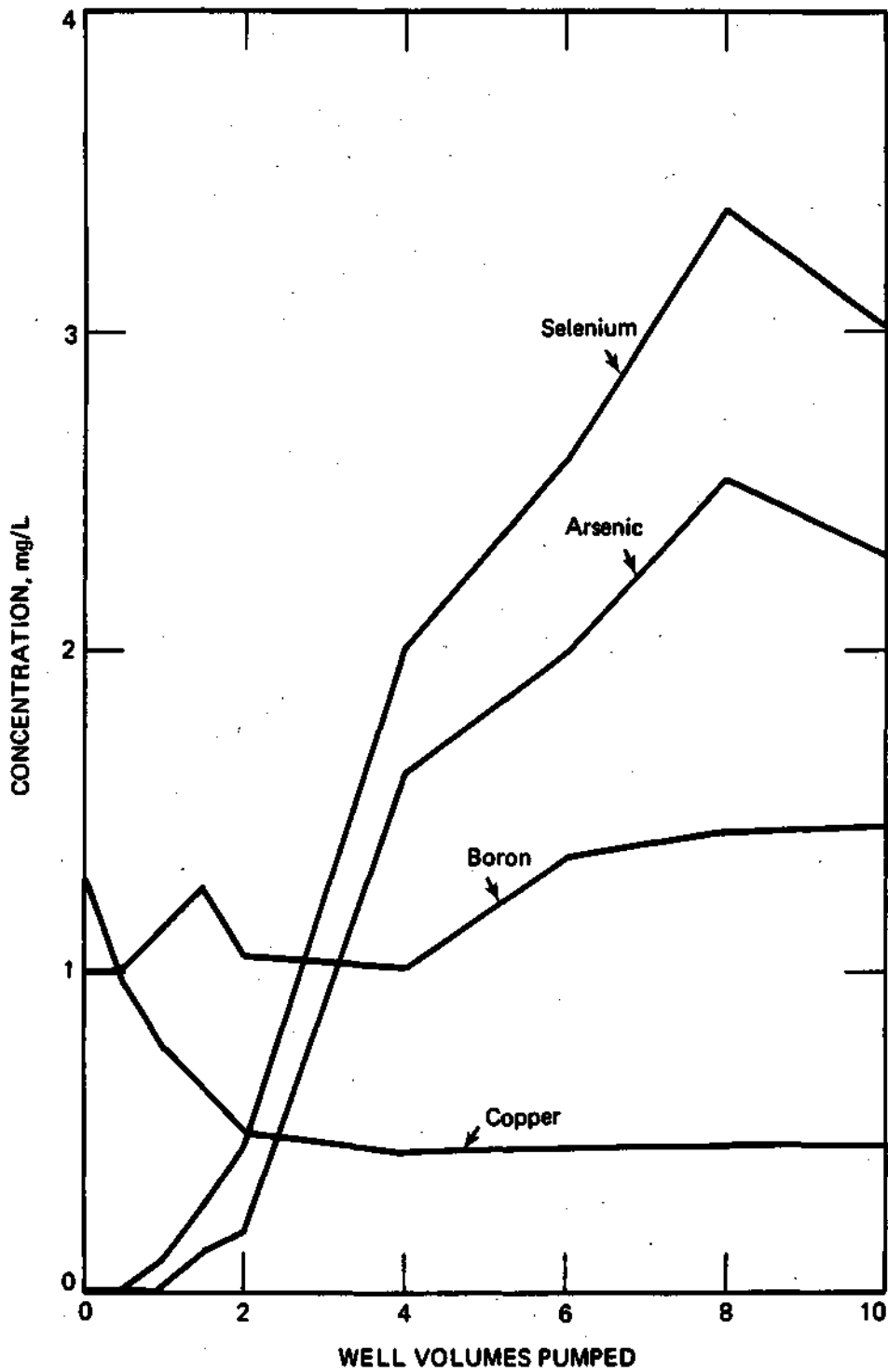

Figure 16. Site 1-SDV: selenium, arsenic, boron, and copper concentrations versus volumes pumped (peristaltic pump)

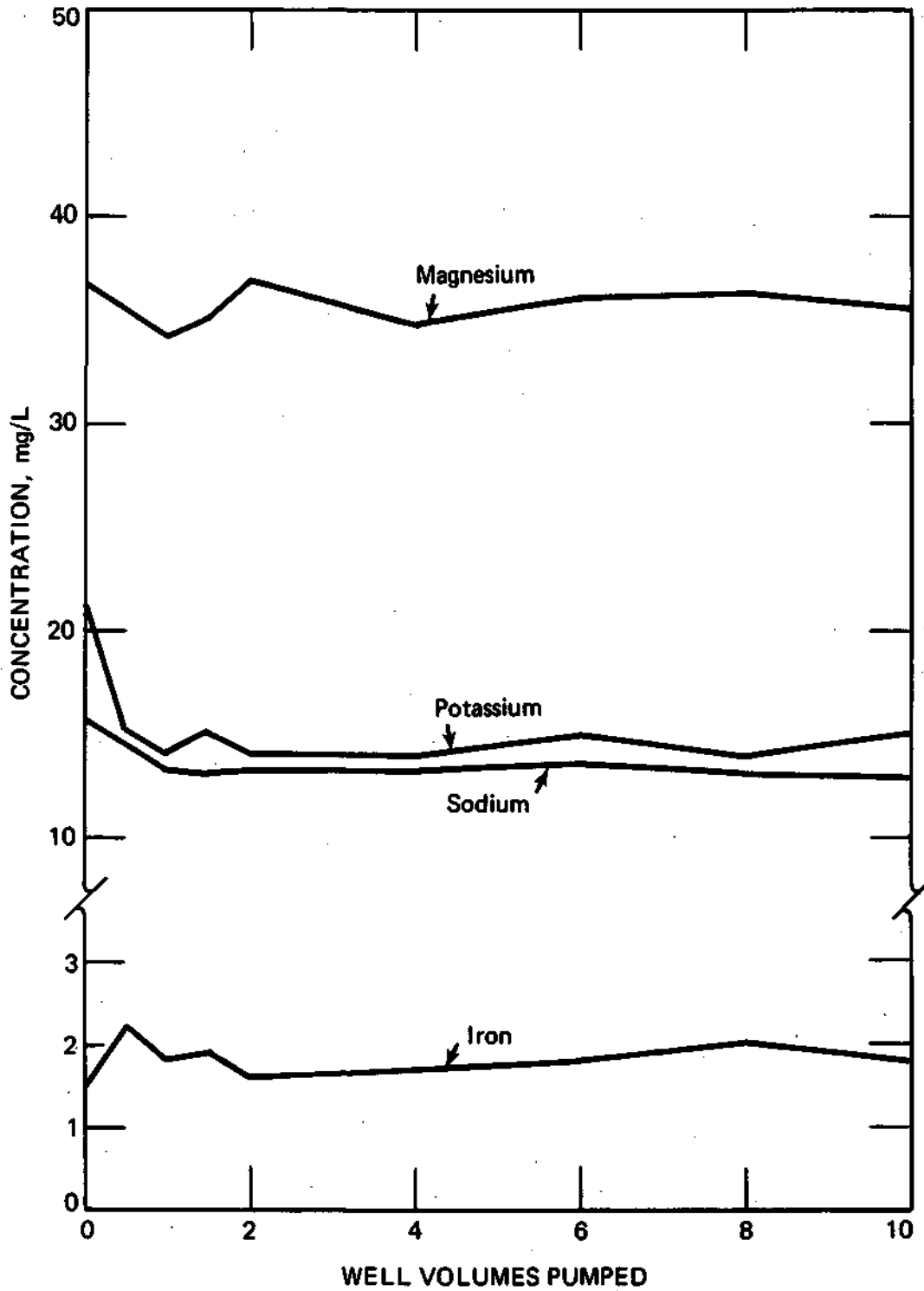

Figure 17. Site 2-ELG: magnesium, potassium, sodium, and iron concentrations versus volumes pumped (peristaltic pump)

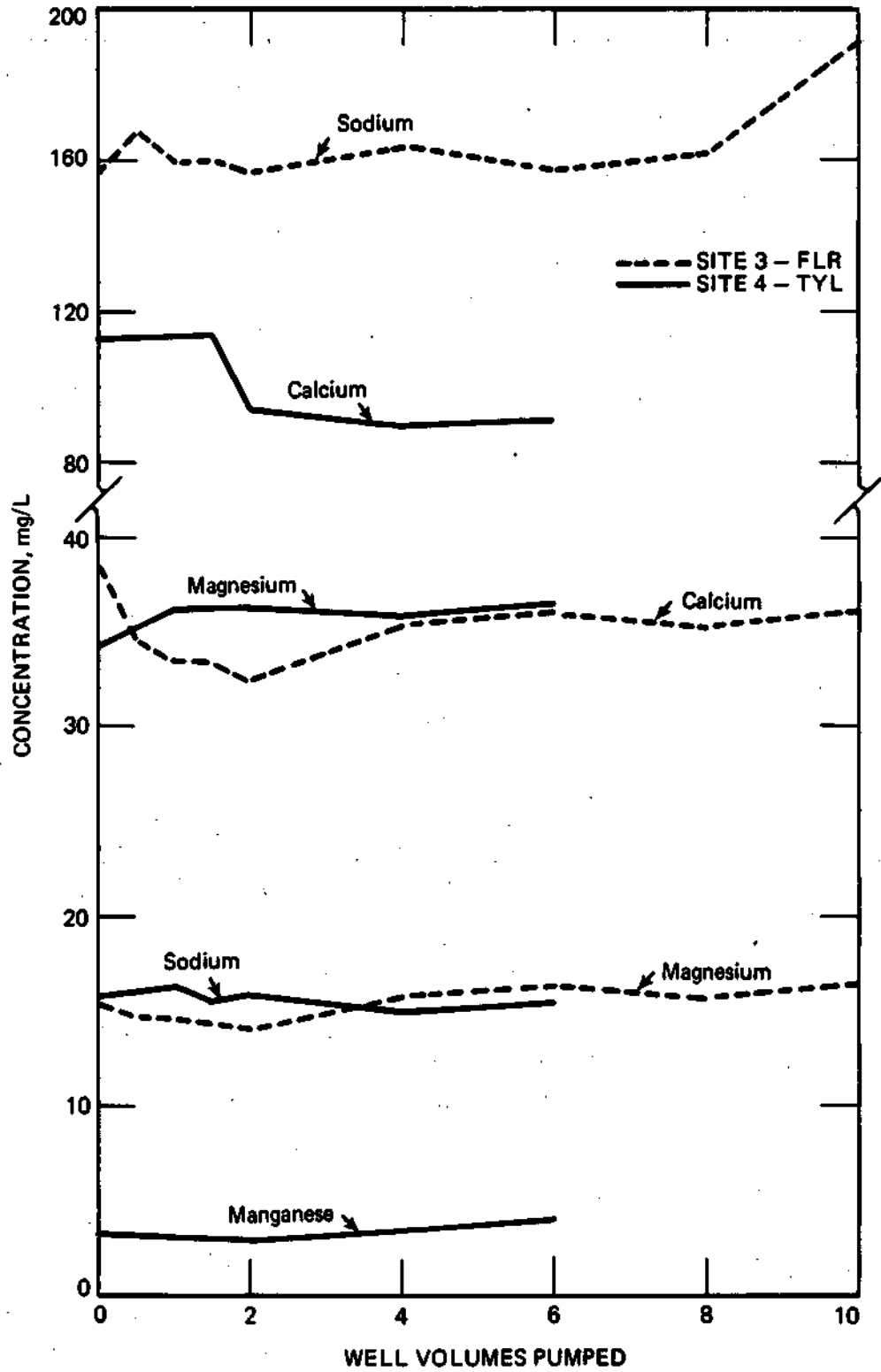

Figure 18. Sites 3-FLR and 4-TYL: sodium, calcium, magnesium, and manganese concentrations versus volumes pumped (peristaltic pump)

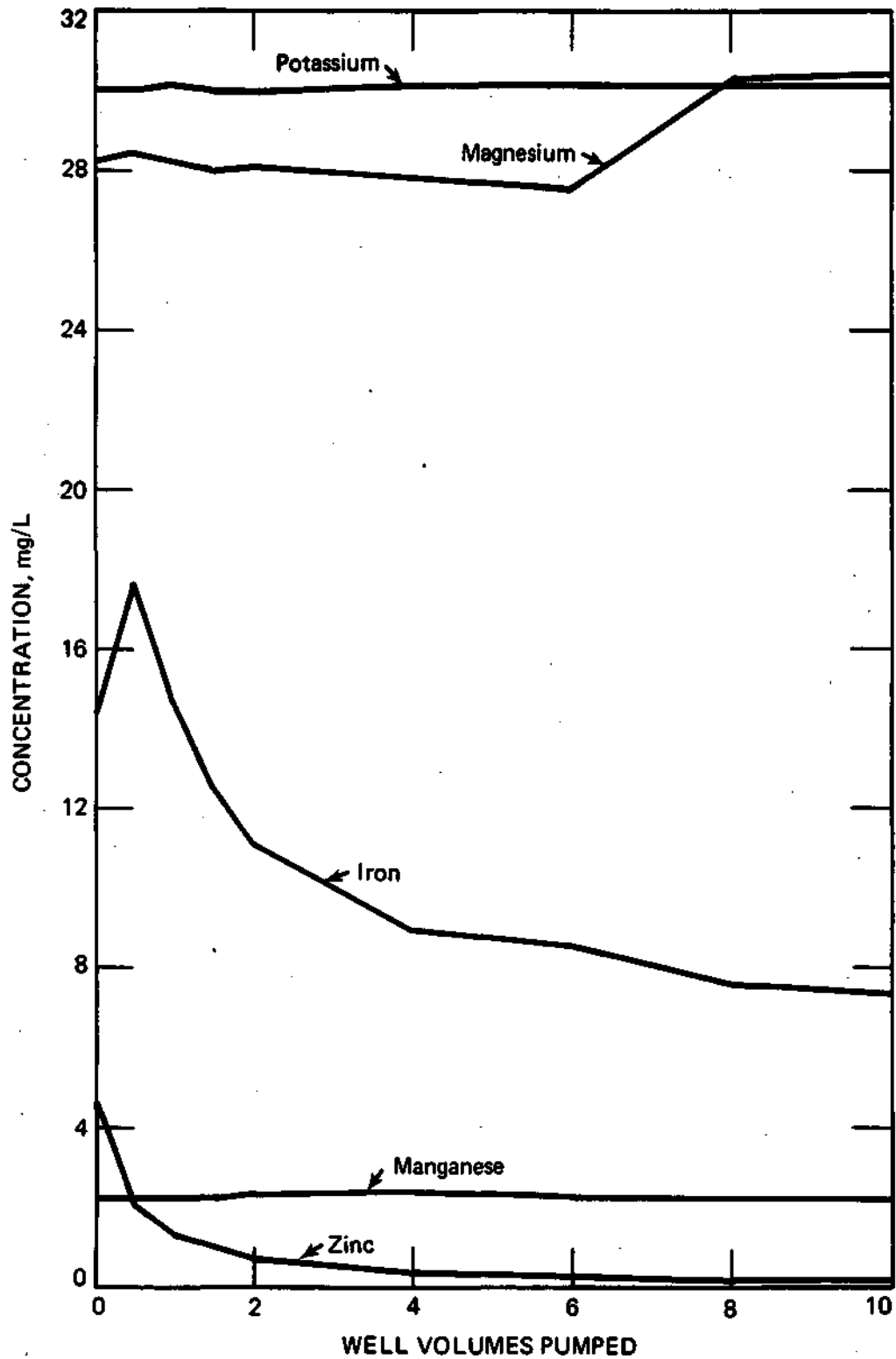

Figure 19. Site 5-BRD: potassium, magnesium, manganese, zinc, and iron concentrations versus volumes pumped (peristaltic pump)

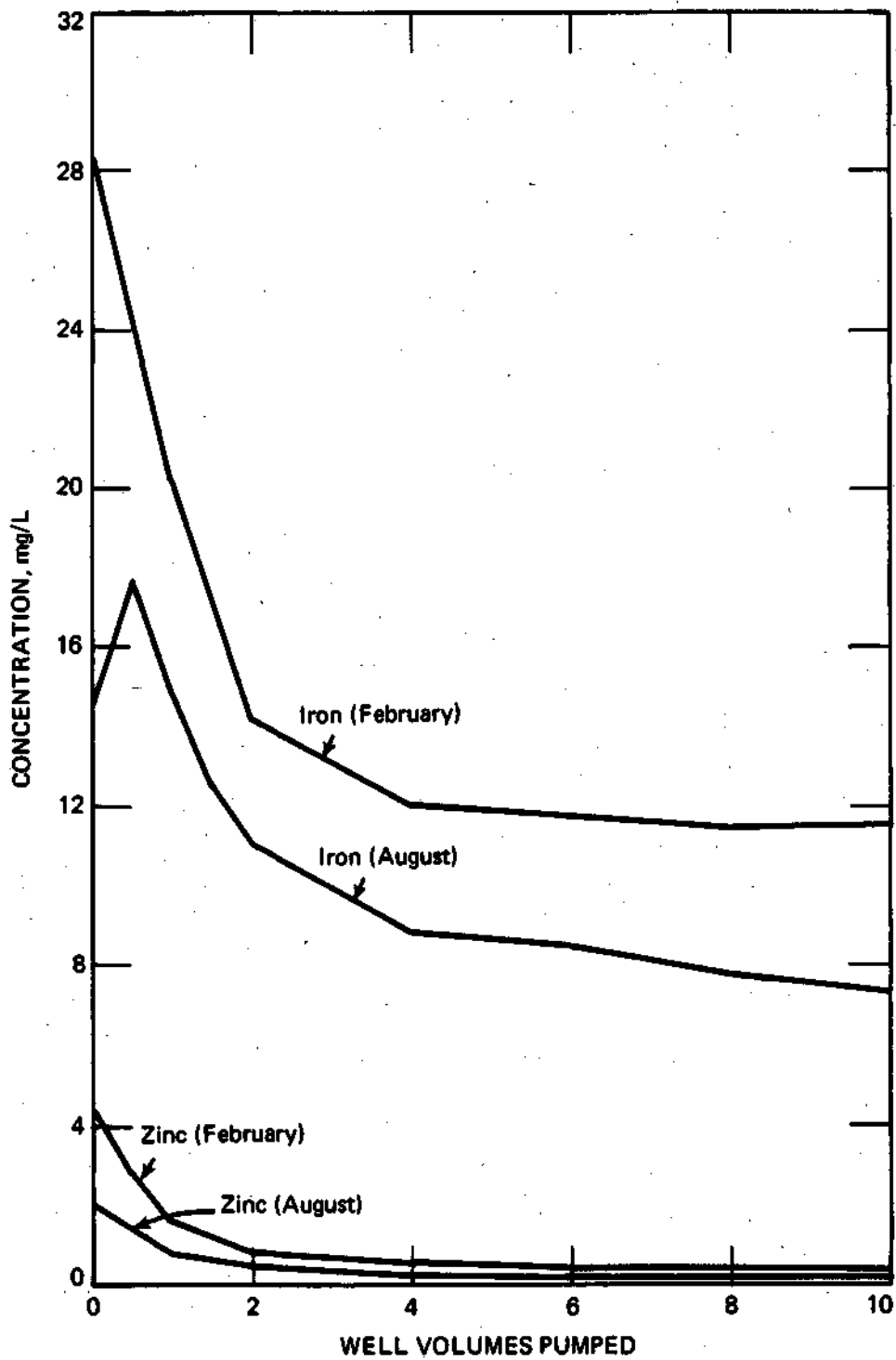

Figure 20. Site 5-BRD: iron and zinc concentrations versus volumes pumped for two sampling periods (peristaltic pump)

Sites 1-SDV and 6-DUP possessed the most unusual hydrogeologic settings of the six sites. In both cases, the monitoring wells were either located in or immediately adjacent to a source of leachate. The close proximity of the monitoring wells to the leachate source presents some additional complications in the interpretation of results. The difficulties encountered at site 6-DUP will be discussed later.

Figures 15 and 16 are plots of some of the major constituents found in the groundwater at site 1-SDV. These figures indicate the changes in these constituent concentrations with the number of well volumes pumped. The sixth, eighth, and tenth well volumes represent relatively consistent concentrations for B, Cu, Cd, and Mn. Boron, Cd, and Mn display similar trends of increasing concentrations in the first four well volumes. The plot of the Cu values shows a steady decrease in the first four well volumes until a stable concentration was reached. Variability in constituent concentration during the first two to four well volumes pumped was presumed to represent mixing of aquifer and storage water. The stable concentrations obtained during the sixth, eighth, and tenth well volumes could be interpreted as "representative" aquifer water. However, the data for As, Se, and Mg, along with Ca and Zn, which were not plotted, indicate an overall increase in concentration of these constituents during the pumping of all ten well volumes. It is believed that this is a case of overpumping due to the placement of the monitoring well next to the waste settling pond, which permits the waste leachate to be drawn directly into the well during extensive pumping. This makes it difficult to determine when a "representative" sample of the aquifer has been obtained for these latter constituents.

Figures 17 and 18 are plots of the major constituents found in the groundwater at sites 2-ELG, 3-FLR, and 4-TYL. The data for these wells indicate that the constituent concentrations do not change appreciably during pumping. This indicates that the water in storage is similar to the water in the aquifer. The lack of any change in the Fe concentration at site 2-ELG was of particular interest. Of all the constituents measured, soluble Fe was perhaps the most likely to exhibit concentration changes between water being held in storage and that present in the groundwater.

Data collected at site 5-BRD dramatically demonstrate the effects of well flushing on sample collection. Figure 19 illustrates the effect of pumping on the concentrations of the major constituents in samples from site 5-BRD. As was the case for the previous sites, K, Mg, and Mn show only slight changes in concentration with the number of well volumes pumped. However, Figure 19 shows that it was necessary to remove as many as eight to ten well volumes before samples with stable concentrations of Fe and Zn were received and a "representative" sample of the aquifer could be collected.

This is in apparent conflict with information derived from the pump test analysis portion of this study, which suggests that nearly 100 percent aquifer water should be expected from the very start of pumping. The decrease of dissolved Fe and Zn concentrations with pumping would indicate that the water in storage was higher in soluble Fe than the aquifer water. It is quite possible since the well at site 5-BRD was the only one studied where the casing material was galvanized steel. The presence of Fe and Zn in the storage water may

be a result of corrosion of or leaching from the well casing. The Fe and Zn may also migrate into the aquifer for a short distance around the well. The removal of this anomalously high Fe and Zn water from the aquifer would be necessary before representative aquifer water samples could be obtained.

For another phase of the project an additional series of samples were collected at sites 5-BRD and 6-DUP using a peristaltic pump. These samples were collected in early February, approximately six months after the first series of samples were taken from the sites using a peristaltic pump. Comparison of the data from the samples collected in February and those collected in August illustrates two additional problems encountered in sampling from shallow monitoring wells.

Figure 20 shows the Fe and Zn values for samples collected from site 5-BRD. The trends of decreasing concentration with volumes pumped were similar for both constituents during both sampling intervals. Although the trends were nearly identical, the concentrations in the samples collected in February were somewhat higher than those in the samples collected in August. This is probably due to seasonal fluctuations in groundwater chemistry induced by rainfall events and temperature changes.

As mentioned previously, the monitoring well at site 6-DUP is similar to the well at site 1-SDV with respect to its proximity to the disposal site. The well at site 6-DUP was placed directly beneath the refuse at a municipal landfill. The landfill also possesses a relatively thin soil cover that allows for rapid recharge by infiltrating rainwater. These factors increase the possibility of seasonal variations in groundwater composition at the site.

Groundwater within the landfill also has an extremely heterogeneous chemical nature, dependent upon its immediate environment within the landfill (Hughes et al., 1968). Thus, sampling from a well placed directly into or beneath the refuse could result in samples exhibiting large fluctuations in chemical composition.

Figure 21 depicts the change in Fe concentration during the pumping of ten well volumes when the well was sampled in both August and February using a peristaltic pump. The decrease in Fe during pumping in August was believed to reflect an aquifer under oxidizing conditions. The trend of increasing Fe in the February samples would indicate that the aquifer (or refuse) was under a reduced environment with more Fe in solution. The presence of a frozen soil cover during winter, creating a closed system and not permitting the introduction of air (oxidants), could explain the reducing environment. The samples collected during August reflect the effects of well flushing (volumes 0 through 4), the oxidizing environment of the summer months (the lower overall Fe concentrations), and the heterogeneous nature of water contained in the refuse (volumes 6 through 10). It appears that it would be very difficult to obtain reproducible "representative" samples of water from this monitoring well. There are too many factors affecting the chemical characteristics of water contained in the water-bearing strata.

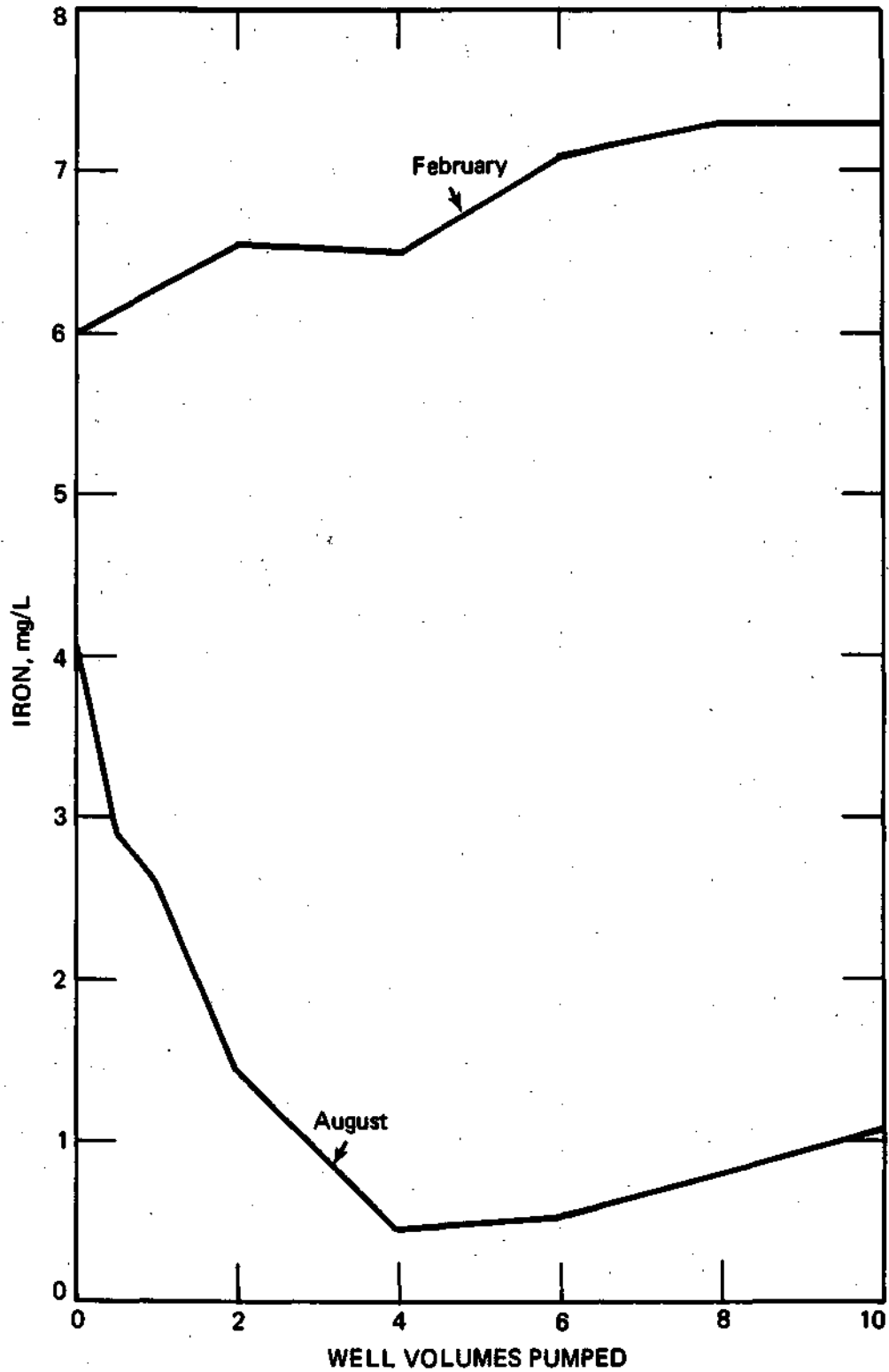

Figure 21. Site 6-DUP: iron concentrations versus volumes pumped for two sampling periods (peristaltic pump)

As previously stated, SO_4^{2-} , F^- , and Cl^- determinations were made on samples collected by peristaltic pump at each of the sites. However, only Cl^- was found at levels above the detection limits of the analytical procedures used. The results of the Cl^- analysis versus well volumes pumped at sites 4-TYL, 5-BRD, and 6-DUP are shown in Figure 22. There were no appreciable changes in Cl^- concentration in the samples taken from sites 4-TYL and 5-BRD. Data from site 6-DUP show some initial fluctuation in the Cl^- values before stable concentrations were obtained. Overall, the data suggest that Cl^- concentrations found in the storage waters were similar to those in the aquifers. The effect of pumping on Cl^- concentrations is of concern since Cl^- , along with pH, temperature, and specific conductance, has often been used to indicate when representative groundwater samples have been obtained. For sites 5-BRD and 6-DUP the Cl^- values vary only slightly with volumes pumped, as do many of the other principal constituents. This suggests that Cl^- would not be a good indicator of when representative aquifer water has been obtained.

In addition to collecting water samples while pumping to determine the effects of well flushing, two sites (2-ELG and 4-TYL) were pumped dry and allowed to recover, and samples were collected. Because of the extremely low permeabilities of the materials tapped by some monitoring wells, it is not always practical to pump all monitoring wells for long periods of time. Tables 6 and 7 present data from samples collected during pumping and immediately after the site 2-ELG and 4-TYL wells were pumped dry with the peristaltic pump.

On the basis of the results of these two brief experiments, it appears that pumping low yielding monitoring wells dry, allowing them to recover, and collecting a water sample during recovery would yield representative chemical results. However, because of the numerous geologic, hydrologic, and chemical factors that can affect the chemical composition of collected samples, it is recommended that a brief experiment similar to those at sites 2-ELG and 4-TYL be conducted prior to accepting this sampling procedure for a particular site.

The chemical data from this portion of the study have verified the theoretical ratios of aquifer to stored water predicted during the pump tests. One group of elements—Na, K, Mg, Ca, and Cl—has been shown to be relatively insensitive to time of pumping or well flushing. Another group of elements—Fe, Mn, Mg, Zn, Cd, Cu, As, Se, and B—is sensitive to the effects of well flushing. These constituents apparently undergo chemical changes when stored in the well casings. These constituents, along with pH, could be used as indicators of when representative samples have been obtained from an aquifer when using a pump system that will not affect their concentrations. The selection of the most suitable indicator should be based on the hydrologic and chemical characteristics of the groundwater at each individual site.

EFFECTS OF SAMPLE PREPARATION, PRESERVATION, AND STORAGE ON CHEMICAL COMPOSITION

The effort to collect a representative groundwater sample from an aquifer via a monitoring well would be futile if the chemical composition of the

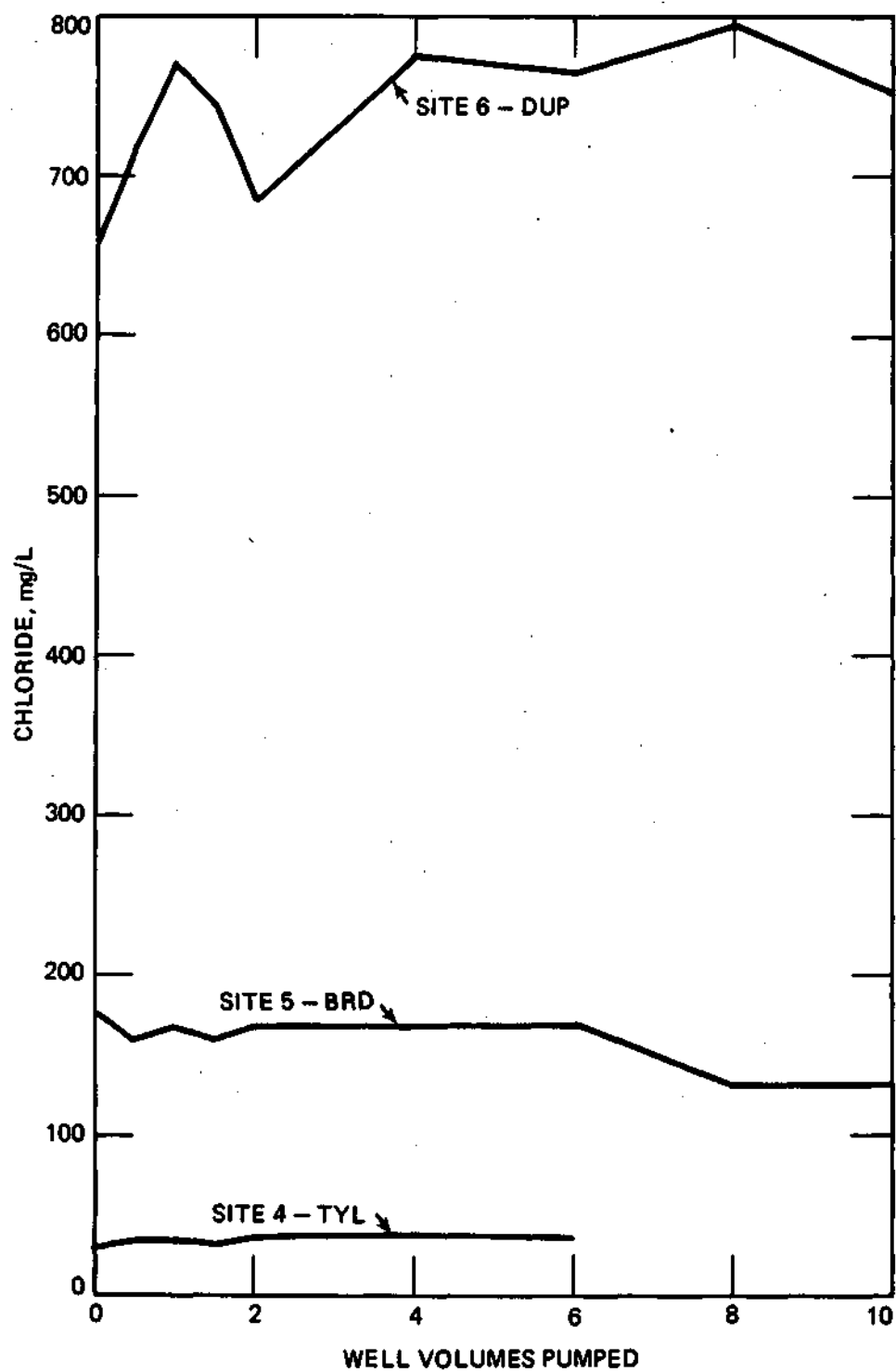

Figure 22. Sites 4-TYL, 5-BRD, and 6-DUP: chloride concentrations versus volumes pumped (peristaltic pump)

Table 6. Analysis of Samples from Site 2-ELG Where the Well Was Placed in Geologic Materials of Low Hydraulic Conductivity (Concentrations in mg/L)

Well	Volume	Ca	Fe	K	Mg	Mn	Na	Zn
	0	13.6	<.01	5.47	4.45	.011	4.35	.188
	2	61.6	5.40	2.51	35.2	.111	14.0	.359
	4	60.9	4.86	2.41	34.5	.098	13.4	.795
	6	60.6	4.53	2.00	34.5	.097	13.4	.222
	after recharge	61.4	4.66	2.03	34.9	.094	13.8	.203

Note: The well was sampled as it was being pumped dry with the peristaltic pump and then resampled after recharge.

Table 7. Analysis of Samples from Site 4-TYL Where the Well Was Placed in Geologic Materials of Low Hydraulic Conductivity (Concentrations in mg/L)

Well	Volume	Ca	Fe	K	Mg	Mn	Na	Zn
	0	104	.018	<1.0	40.0	.118	14.9	.037
	1	102	.182	<1.0	39.5	.727	17.1	.025
	1 1/2	107	.503	<1.0	39.2	2.06	15.1	.019
	after recharge	102	.757	<1.0	39.2	2.03	16.2	.003

Note: The well was sampled as it was being pumped dry with the peristaltic pump and then resampled after recharge.

sample changed between the time of collection and analysis. Proper sample preparation, preservation, and storage can help prevent such changes from occurring. Adequate procedures have been developed for sample preservation, and many investigations into the proper vessels for sample storage have also been completed. This phase of the project was primarily concerned with whether these prescribed procedures for preparation and preservation of samples should be applied on-site immediately after sample collection or in the laboratory some time later.

The effects of filter pore size on sample chemical composition were also studied. Subsamples, filtered through either a 3.0, 0.45, or 0.22 μm pore size filter, were taken from each well volume or partial well volume collected during the monthly sampling routines. The analyses of these subsamples were then compared to determine the effect of membrane pore size on constituent concentration in the filtered samples. Tables 8 and 9 list representative results from the filtration study. These data show that the membrane pore size used for sample preparation does not affect the concentrations of Ca, Mg, and Na in solution. The same was found to be true for K and Mn.

However, the Fe and Zn concentrations showed a definite effect from filter pore sizes. The highest Fe and Zn concentrations were found in the samples filtered through the 3.0 μm pore size membrane. The next highest concentrations were found in the samples filtered through the 0.45 μm filters. The lowest concentrations of Fe and Zn were found in samples filtered through the 0.22 μm filters. The disparity in concentration values was considerably greater for those samples filtered through a 3.0 μm pore size membrane than for those filtered through the 0.45 and 0.22 μm pore size membranes. This was especially true for the site 6-DUP samples.

The site 5-BRD samples did not show as great a difference in Fe concentration between those samples filtered with the 3.0 μm pore size membranes and those filtered through either 0.45 or 0.22 μm pore size membranes. The site 6-DUP samples were very turbid, and colloidal material was observed to pass through the 3.0 μm membrane but not the 0.45 or 0.22 μm pore size membranes. Subsequent acidification of the samples for preservation resulted in leaching or dissolution of Fe and Zn from these colloidal particles.

The 4-L samples taken at the tenth well volumes from sites 5-BRD and 6-DUP during the February samplings were used for the storage analysis. The results of this phase of the project are presented in Table 10.

Calcium, K, Mg, Mn, and Na show little change in chemical composition in response to storage time. During the 72-hour period of the study, these constituents displayed only a slight fluctuation in concentration. This fluctuation may have been due to difficulty in subsampling the 4-L bottles.

The changes in pH, Fe, and Zn, however, were immediate. During the 7 hours between collection of the samples and return to the laboratory, where a subsample of the larger volumes was taken, these parameters underwent significant change. The initial pH for samples from both sites increased 0.3 and 0.4 pH units for sites 5-BRD and 6-DUP, respectively, during the first 7 hours. After that time, the values remained constant. Almost all of the

Table 8. Sites 2-ELG, 3-FLR, 5-BRD, and 6-DUP: Calcium, Magnesium and Sodium Concentrations of Samples Filtered Through Different Pore Size Membranes (Concentrations in mg/L)

Well Volume	Pore Size	Ca		Mg		Na	
		Site 3	Site 5	Site 3	Site 6	Site 2	Site 6
0	3.0	39.5	76.6	15.7	118	17.8	192
	.45	38.8	75.9	15.2	114	17.9	222
	.22	39.5	75.1	15.6	113	17.9	228
1/2	3.0	34.6	72.6	14.6	122	14.6	262
	.45	34.4	72.0	14.7	127	14.9	260
	.22	34.9	72.6	14.8	124	15.2	252
1	3.0	34.0	70.9	14.7	121	14.7	268
	.45	33.4	70.5	14.4	118	14.6	238
	.22	34.6	71.1	14.9	121	14.5	250
1-1/2	3.0	32.9	70.1	14.1	119	14.2	224
	.45	33.3	69.5	14.3	124	13.9	246
	.22	33.5	69.7	14.3	121	14.0	248
2	3.0	32.8	73.2	14.2	121	17.3	246
	.45	32.5	73.0	14.0	120	14.2	200
	.22	33.1	73.3	14.2	122	14.0	250
4	3.0	35.5	71.9	15.8	137	13.4	250
	.45	35.6	72.0	15.9	135	13.6	246
	.22	35.6	71.4	15.9	136	13.4	248
6	3.0	35.6	72.4	16.0	135	13.8	258
	.45	36.3	71.7	16.3	134	13.9	260
	.22	36.6	72.6	16.7	132	13.8	248
8	3.0	35.5	73.0	16.1	134	16.2	262
	.45	35.3	72.2	15.9	136	16.1	258
	.22	35.1	73.3	15.9	131	15.9	258
10	3.0	35.7	71.7	16.4	130	19.5	266
	.45	36.1	72.5	16.5	131	19.4	266
	.22	36.4	74.6	16.6	132	19.7	268

Table 9. Sites 5-BRD and 6-DUP: Iron and Zinc Concentrations of Samples Filtered Through Different Pore Size Membranes (Concentrations in mg/L)

Well Volume	Pore Size	Fe			Zn		
		Site 5 (mech)*	Site 6 (air)**	Site 6 (mech)	Site 5 (mech)	Site 6 (mech)	Site 6 (air)
0	3.0	14.7	3.44	4.89	4.69	.428	.137
	.45	14.6	.52	4.04	4.54	.066	.078
	.22	14.1	.49	2.69	4.45	.077	.075
1/2	3.0	18.1	3.40	7.65	2.22	.039	.088
	.45	17.7	.62	2.92	2.09	.037	.057
	.22	17.3	.51	2.30	2.00	.032	.053
1	3.0	15.4	3.67	7.35	1.54	.039	.064
	.45	14.9	.61	2.61	1.43	.031	.043
	.22	15.1	.52	2.51	1.43	.024	.044
1-1/2	3.0	13.1	3.12	8.37	1.19	.039	.079
	.45	12.6	.63	6.96	1.11	.036	.049
	.22	12.4	.49	3.02	1.08	.022	.044
2	3.0	11.7	4.67	4.52	1.09	.037	.060
	.45	11.1	.45	1.46	.89	.023	.035
	.22	11.1	.42	1.39	.88	.022	.037
4	3.0	9.23	5.46	1.41	.66	.034	.084
	.45	9.00	.62	.47	.51	.022	.056
	.22	8.82	.50	.50	.51	.022	.053
6	3.0	9.01	4.10	.93	.55	.032	.063
	.45	8.64	.49	.52	.37	.019	.037
	.22	8.66	.44	.74	.36	.019	.037
8	3.0	8.09	4.91	1.67	.42	.026	.044
	.45	7.75	.46	.78	.28	.017	.064
	.22	7.76	.46	.75	.26	.021	.030
10	3.0	7.56	4.84	2.66	.39	.021	.040
	.45	7.36	.46	1.10	.24	.016	.024
	.22	7.33	.44	1.31	.22	.018	.032

* mech = peristaltic pump

** air = air lift pump

dissolved Fe and Zn present in the samples was lost during the first 7 hours of storage. This loss could be due to adsorption onto the walls of the container. The latter is unlikely due to the magnitude of the concentration decrease. The most probable cause of reduction of the Fe concentrations is precipitation.

Parameters such as pH, Eh, and specific conductance should be measured in the field at the time of sample collection. A closed cell that permits these measurements to be made on samples before they are exposed to atmospheric conditions is recommended. All samples should be filtered through a 0.45 µm pore size membrane while on-site, immediately after sample collection. The samples should then be preserved and stored in linear polyethylene bottles and returned to the laboratory according to recommended methods (U.S. EPA, 1979).

Table 10. Sites 5-BRD and 6-DUP: Analysis of the Tenth Well Volume Sample Used for Storage Study (Concentrations in mg/L)

Site 5-BRD

Hours after collection- before preservation	pH	Ca	Fe	K	Mg	Mn	Na	Zn
0	6.7	111.	11.6	32	44.6	3.81	186	0.18
7	7.0	110.	.33	31	41.9	3.15	172	0.02
24	7.0	104.	<.03	35	41.4	3.10	181	0.02
48	7.0	99.	.03	33	39.5	2.98	171	0.02

Site 6-DUP

Hours after collection- before preservation	pH	Ca	Fe	K	Mg	Mn	Na	Zn
0	6.8	32.5	5.74	189	94.2	ND*	215	ND*
7	7.2	35.2	<.08	203	110.	ND*	242	ND*
24	7.2	32.0	<.08	204	96.6	ND*	223	ND*
48	7.2	30.1	.34	184	89.1	ND*	204	ND*

*ND - not detectable

REFERENCES

- Brown, E., M. W. Skougstad, and M. J. Fishman. 1970. Methods for Collection and Analysis of Water Samples for Dissolved Minerals and Gases. Tech. Water-Resources Inv., Bk. 5, Chap. A1, U.S. Geological Survey.
- Chian, Edward S., and Foppe B. DeWalle. 1975. Compilation of Methodology Used for Measuring Pollution Parameters of Sanitary Landfill Leachates. U.S. Environmental Protection Agency, Cincinnati, OH. EPA-600/3-75-011.
- Fenn, D., E. Cocozza, J. Isbister, O. Braids, B. Yare, and P. Roux. 1977. Procedures Manual for Ground Water Monitoring at Solid Waste Disposal Facilities. U.S. Environmental Protection Agency, Cincinnati, OH. EPA/530/SW-611.
- Gibb, J. P., K. Cartwright, D. Lindorff, and A. Hartley. 1978. Field Verification of Hazardous Waste Migration from Land Disposal Sites, EPA publication in press.
- Gilkeson, R. H., K. Cartwright, L. R. Follmer, and T. M. Johnson. 1977. Contribution of Surficial Deposits, Bedrock and Industrial Wastes to Certain Trace Elements in Ground Water. Proceedings of the 15th Annual Symposium on Engineering Geology, Pocatello, Idaho.
- Hughes, G. M., R. A. Landon, and R. N. Farvolden. 1968. Hydrogeology of Solid Waste Disposal Sites in Northeastern Illinois. Progress Report to the Department of Health, Education, and Welfare on Demonstration Grant No. 5-D01-00006-02.
- Hughes, G. M., R. A. Landon, and R. N. Farvolden. 1971. Hydrogeology of Solid Waste Disposal Sites in Northeastern Illinois. U.S. Environmental Protection Agency, Washington, D.C. SW-12d.
- Jackson, R. E., and K. J. Inch. 1980. Hydrogeochemical Processes Affecting the Migration of Radionuclides in a Fluvial Sand Aquifer at the Chalk River Nuclear Laboratories. Environment Canada, NHRI Paper No. 7, Scientific Series No. 104.
- Jacob, D. E. 1950. Flow of Ground Water. Engineering Hydraulics, edited by H. Rouse, John Wiley and Sons, New York.
- Jenne, E. A. 1968. Controls of Mn, Fe, Co, Ni, Cu, and Zn Concentrations in Soils and Water: The Significant Roles of Hydrous Mn and Fe Oxides, in Trace Organics in Water. Amer. Chem. Soc. Adv. Chem., Ser. 73.
- Kennedy, V. C, G. W. Zellweger, and B. F. Jones. 1974. Filter Pore-Size Effects on the Analysis of Al, Fe, Mn, and Ti in Water. Water Resources Research, vol. 10, p. 785-790.
- Manahan, S. E. 1972. Environmental Chemistry. Willard Grant Press, Boston, Massachusetts.

- Mooij, H., and F. Rovers. 1975. Recommended Groundwater and Soil Sampling Procedures. Environment Canada, Seminar Proceedings, Sept. 18 and 19.
- Papadopoulos, I. S., and H. Cooper. 1967. Drawdown in a Well of Large Diameter. Water Resources Research, 3(1):241-244.
- Rattonetti, A. 1976. Stability of Metal Ions in Aqueous Environmental Samples. National Bureau of Standards Special Publication 422, p. 633-648.
- Schafer, D. C. 1978. Casing Storage Can Affect Pumping Test Data. The Johnson Drillers Journal.
- Schmidt, K. D. 1977. Water Quality Variations for Pumping Wells. Groundwater, vol. 15, no. 2, p. 130-137.
- Shendrikar, A. D., V. Dharmarajan, H. Walker-Merrick, and P. W. West. 1975. Adsorption Characteristics of Traces of Barium, Beryllium, Cadmium, Manganese, Lead, and Zinc on Selected Surfaces. Anal. Chem. Acta, 84, p. 409-417.
- Sommerfeldt, T. G., and D. E. Campbell. 1975. A Pneumatic System to Pump Water from Piezometers. Ground Water, 13(3), p. 293.
- Struempfer, A. W. 1973. Adsorption Characteristics of Silver, Lead, Cadmium, Zinc, and Nickel on Borosilicate Glass, Polyethylene, and Polypropylene Container Surfaces. Anal. Chem., vol. 45, no. 13.
- Stumm, W., and J. J. Morgan. 1970. Aquatic Chemistry. New York: Wiley-Interscience.
- Subramanian, K. S., C. L. Chakrabarti, J. E. Sueiras, and I. S. Maines. 1978. Preservation of Some Trace Metals in Samples of Natural Waters. Anal. Chem., vol. 50, no. 3.
- Summers, W. K., and C. A. Brandvold. 1967. Physical and Chemical Variations in the Discharge of a Flowing Well. Ground Water, vol. 5-6, no. 1.
- Theis, C. V. 1935. The Relation Between the Lowering of the Piezometric Surface and the Rate and Duration of Discharge of a Well Using Ground-Water Storage, Trans. Am. Geophys. Union, 16, 518-524.
- Trescott, P. C, and G. F. Pinder. 1970. Air Pump for Small-Diameter Piezometers. Ground Water, vol. 8, no. 3.
- United States Environmental Protection Agency. 1979. Methods for Chemical Analysis of Water and Wastes. EPA-600/4-79-020. Cincinnati, Ohio.
- Wagemann, R., and C. J. Brunskill. 1975. The Effect of Filter Pore-Size on Analytical Concentrations of Some Trace Elements in Filtrates of Natural Water. Intern. J. Environ. Anal. Chem., vol. 4, pp. 75-84.