

ISWS
B
26
Loan c. 3

STATE OF ILLINOIS
DEPARTMENT OF REGISTRATION AND EDUCATION

DIVISION OF THE
STATE WATER SURVEY
A. M. BUSWELL, Chief

BULLETIN NO. 26

THE DEPTH OF SEWAGE FILTERS AND
THE DEGREE OF PURIFICATION

BY A. M. BUSWELL, S. I. STRICKHOUSER,
AND OTHERS



[Printed by authority of the State of Illinois]

URBANA ILLINOIS

BULLETINS OF THE ILLINOIS STATE WATER SURVEY

No. 19.

No. 10.

No. 11.

No. 12.

No. 13.

No. 14.

No. 15.

No. 16.

No. 17.

No. 18.

No. 19.

No. 20.

DATE DUE

Report

Report

Report

Report

Report

Report

Report

print.
49 pp.
de on
son of

A

No. 21.

No. 22.

No. 23.

No. 24.

No. 25.

No. 26.

No. 27.

on of
(nts.)
cuts.

tion,

ago.

aps.

50

nts.

otic

ISWS
B
26
Loan
c. 3
05032004
2204
CHAMPAIGN

**Buswell, A.M.
THE DEPTH OF SEWAGE
FILTERS AND THE
DEGREE OF PURIFICATION.**

DEMCO

For c

STATE OF ILLINOIS
DEPARTMENT OF REGISTRATION AND EDUCATION

DIVISION OF THE
STATE WATER SURVEY
A. M. BUSWELL, Chief

BULLETIN NO. 26

THE DEPTH OF SEWAGE FILTERS AND
THE DEGREE OF PURIFICATION

BY A. M. BUSWELL, S. I. STRICKHOUSER,
AND OTHERS



[Printed by authority of the State of Illinois]

URBANA. ILLINOIS

ORGANIZATION

STATE OF ILLINOIS

LEN SMALL, *Governor*

DEPARTMENT OF REGISTRATION AND EDUCATION

A. M. SHELTON, *Director*

Board of Natural Resources and Conservation Advisers

A. M. SHELTON, *Chairman*

WILLIAM A. NOTES, Chemistry,
Secretary

JOHN W. ALVORD, Engineering

EDSON S. BASTIN, Geology

HENRY C. COWLES, Forestry

WILLIAM TRELEASE, Biology

C. M. THOMPSON, Representing
the president of the University
of Illinois

State Water Survey Division Committee

A. M. SHELTON

C. M. THOMPSON

WILLIAM A. NOYES

JOHN W. ALVORD

STATE WATER SURVEY DIVISION

A. M. BUSWELL, *Chief*

CONTENTS

	PAGE
Letter of transmittal	4
Part I. Studies on the relation of the depth of a sprinkling filter to the degree of purification, by S. I. STRICKHOUSER with A. M. BUSWELL	5
Development of the sprinkling filter.....	8
Theory of purification by the sprinkling filter.....	14
Review of previous work on the relation of depth to degree of purification	26
Experimental procedure and results.	37
Discussion of results.	61
General summary.	64
Appendix to Part I	65
Bibliography.	78
Part II. Confirmatory data from experimental trickling filter, by A. M. BUSWELL, E. L. PEARSON, and G. E. SYMONS.	81
Part III. Trickling filter dosing, by G. C. HABERMEYER and H. L. WHITE	91
Part IV. Biological data on the sprinkling filter, by S. L. NEAVE with A. M. BUSWELL.....	95

LETTER OF TRANSMITTAL

August 7, 1928.

A. M. Shelion, Chairman, and Members of the Board of Natural Resources and Conservation Advisers:

GENTLEMEN : Herewith I submit a report of studies on the depth of sewage filters and the degree of purification, and recommend that it be published as Bulletin No. 26 of the Illinois State Water Survey. This report summarizes work carried on in part at the treatment works of the Urbana-Champaign Sanitary District and in part at the experimental plant maintained in cooperation with the University of Illinois. The assistance of cooperating agencies is hereby gratefully acknowledged.

We trust that the results of the investigation will justify a more economical design of sewage filters than has formerly been considered necessary.

Respectfully submitted,

A. M. BUSWELL, *Chief.*

PART I

**STUDIES ON THE RELATION OF
THE DEPTH OF A SPRINKLING
FILTER TO THE DEGREE
OF PURIFICATION***

BY S. I. STRICKHOUSER WITH A. M. BUSWELL

The problem of the treatment and disposal of human wastes is one which is demanding an ever-increasing amount of attention. It has long been known that the health of a community depends upon the prompt disposal of its sewage, and it is now being gradually recognized that the community should assume the responsibility for the treatment of its own sewage and not put this unnatural load on the rivers and lakes. Proper treatment of sewage safeguards the public health, preserves the normal aquatic life in our streams, and prevents nuisances which offend the eye and destroy the scenic beauties of our natural watercourses.

The earliest methods for the disposal of sewage were direct discharge into a watercourse and application to land. Direct discharge into a stream is generally satisfactory to the community immediately concerned, but in most cases it is a most harmful and undesirable practice to the people down-stream. Application to land in such quantities as to allow sufficient aeration and drainage offers a method for obtaining rapid disintegration and oxidation to stable organic material, but because of the large area required this method is impracticable for the treatment of the sewage of a large modern city.

In Europe, sewage treatment by irrigation was begun before 1400 in Lausanne, when a brook receiving some sewage was used for

* A thesis submitted in partial fulfillment of the requirements for the Degree of Doctor of Philosophy in Chemistry in the graduate School of the University of Illinois, 1926.

irrigation purposes. The first project of this type designed primarily to treat sewage was begun in Bunzlau, Prussia, in 1559. For over three hundred years this area purified sewage without any appreciable decrease in efficiency.

In a report on the "Health of the Working Classes" in 1842, Chadwick called the attention of English authorities to the fact that Craigentenny Meadows had successfully handled Edinburgh sewage for many decades without losing its efficacy as a purifying agent. This observation marked the beginning of a long series of sewage irrigation projects in England. These so-called "sewage farms" were not the outcome of scientific research, but were rather the blind imitation of successful precedent.

The principles of scientific investigation were not applied to the question of sewage treatment until 1868, when Sir Edward Frankland, a member of the Royal Commission of 1868, conducted a series of experiments on sewage filtration. He showed that natural land or artificial filters did not clog if the sewage was applied in small quantities and allowed to trickle away before the application of the next dose. This principle of "intermittent filtration" is the fundamental one upon which all further progress in this field has been founded.

The outcome of Frankland's early experiments on filtration of sewage is the modern sprinkling filter. The present-day importance of this method of treatment entitles its development to a separate discussion, which will be presented later. Only a general statement of the construction and theory of operation of the sprinkling filter is given at this point.

Sprinkling filters are sometimes called percolating filters, intermittent-continuous filters, oxidizing beds, bacteria beds or biological filters. While each of these names has some merit, the term "sprinkling filters" seems to be the most widely used and will be adhered to in this discussion.

Sprinkling filters are beds of crushed rock or other coarse material, such as coke or clinkers, upon which sewage is distributed and through which it trickles freely. The sewage is generally applied by spraying, although other means are sometimes employed whereby an equally effective distribution is obtained.

Although much has been learned about the theory and operation of the sprinkling filter in the last twenty-five years, many of its interesting problems are still awaiting solution. One of these problems

concerning which there is a difference of opinion is the determination of the relation of the depth of the filter to the degree of purification obtained.

The Fifth Report of the British Royal Commission on Sewage Disposal describes the earliest scientific studies on the most effective depth for coarse-grained filters. As a result of studies on sprinkling filters at Ilford, England, they formulated the opinion that within certain limits a cubic yard of filter medium will perform the same amount of work in a shallow filter as in a deep one. The results of their observations form the basis of the current engineering practice in the design of sprinkling filters, which rates the capacity of the filter on a population per acre-foot basis (see page 27). On this basis, it is implied that a filter ten feet deep will treat twice as much sewage as a filter of equal area five feet deep. Such practice assumes that the purification process is directly proportional to the depth of the filter, and that the purification per foot of depth is constant.

A second view resulted from experiments at Baltimore (see page 28) and Philadelphia (see page 29) about 1908, which indicated that there was a definite limit to the depth of the filter, beyond which the degree of purification was increased only slightly or not at all. Opposed to this is a third view based on experimental evidence obtained about 1914 at the Lawrence Experiment Station (see page 50), from which it was concluded that, as the depth of the bed was increased, the rate of filtration could be increased to a greater extent than the arithmetical proportion would indicate.

A fourth view has been maintained by Eudolfs (see page 33), working at the Sewage Substation of the New Jersey Agricultural Experiment Station. Experiments on the sprinkling filters at Plainfield seemed to show that only the last six inches of the filter were effective. Nitrification and removal of ammonia were said to take place almost exclusively in this six-inch layer of "activated humus."

In 1924 the construction of a ten-foot sprinkling filter for the Urbana-Champaign Sanitary District offered an opportunity for the study of this problem: namely, the progress of the purification in the filter at various depths. This thesis is the report of the investigation carried out on this question.

DEVELOPMENT OF THE SPRINKLING FILTER

About 1865, Dr. Alexander Mueller,¹ a well-known chemist of Berlin, showed that sewage could be purified through digestion and mineralization by micro-organisms. His experiments, however, did not meet with such lasting success as did the classical ones of Sir Edward Frankland² in 1868. Frankland set up filtration experiments in the laboratory, using glass cylinders six feet high and about ten inches in diameter, open at the top and bottom and placed over earthenware troughs. A glass tube was inserted in the middle for aeration purposes. Five different filter media were used: coarse gravel, sand, soil, loamy marl and peaty soil. The filters were dosed morning and evening with crude London sewage applied at different rates. After four months of successful purification, Frankland laid down the well-known principle of "intermittent filtration" mentioned in the introduction. So favorably were the members of the Royal Commission impressed with the results, that they recommended intermittent land filtration as a satisfactory method for the treatment of sewage.

After a series of thirty-eight unsuccessful experiments by English towns on this method of land filtration, it seemed probable that Frankland's observations were soon to be forgotten. It was not recognized at that time that the failures recorded were due to the use of unsuitable land, overloading, or inadequate resting and aeration.

In 1886, the Massachusetts State Board of Health was granted the power to study the general question of stream pollution and sewage treatment. For this purpose, an experiment station was established at Lawrence in 1887. In the Board Report for that year it was stated that for Massachusetts interests, as well as the general interest, it was necessary to carry out careful experiments on Frankland's filtration process. These studies showed the correctness of Frankland's early views and furnished much valuable data on the theory and operation of the intermittent sand filter. Just as Frankland's experiments may be regarded as forming the foundation of natural biological methods of sewage treatment, so may the early work of the Lawrence Experiment Station be regarded as forming the basis for modern artificial biological methods.

The study of the intermittent sand filter at Lawrence led to a search for methods of obtaining higher rates of filtration and a decrease in surface clogging and accumulation of solids in the bed. As a beginning in this direction, two gravel filters, each being one twenty-thousandth of an acre in area and about five feet deep, were constructed and put into operation in June, 1889.³ The stones used in one of these filters were of such size that they would pass through a mesh .375 inch square but not through a mesh .125 inch square. "The stones used in the other filter were somewhat larger, being of such size that they would pass through a mesh 1.25 inches square but not through a mesh .75 inch square.

Sewage was applied to one of these filters, number 16 A, at the average rate of 70,000 gallons per acre per day for a period of four months. This rate was secured by the application of sewage to a depth of about one-third of an inch on the filter surface at hourly intervals for nine hours a day. Nitrification became very active in less than four weeks, and during the entire period of operation the nitrates in the effluent averaged 10.6 parts per million.

The results obtained in the operation of these small filters led to the observation that purification of sewage by nitrification, and the removal of bacteria, is not mechanical to any great extent. This had been suggested in the case of the sand filter, but it was not so clearly demonstrated as with a filter of coarse gravel. With such material, the possibility of straining through fine pores is practically eliminated. The essential feature of filtration through a coarse medium, as stated in the Lawrence reports, is "the slow movement of the liquid in films over the surface of the stones in contact with air."

The adoption of coarse gravel as a filtering medium made it necessary to find a new means of distributing the sewage over the bed. In the sand filters, sewage was allowed to flow onto the bed and distribute itself by flooding the entire filter. In the gravel filters, sewage did not spread out over the surface, but passed directly downward through the large interstices without being purified. It was early determined⁴ that without effective distribution at the surface the sewage could not percolate through the bed in films; instead, it would rush downward in large volumes in some parts of the filter and not reach other parts. The earliest means used for securing equal distribution over such a filter was an automatic siphon discharging upon a dash-plate on the surface of the filter, described by the Lawrence Experiment Station⁵ in 1891. This device gave fairly

satisfactory results on the small experimental filters, but was impracticable for any large installation.

In 1891, O. E. Waring, Jr.⁶ patented a filter which required forced aeration. A top layer of fine gravel placed over the coarser material of the filter was used to secure even distribution by causing the sewage to flood the top of the bed. The fine surface layer hindered the natural aeration of the filter, and for this reason it was necessary to blow air up through the bed. In Waring's words: "the sewage trickles down in a thin film over the surfaces of the particles of coke or other filtering material, while through the voids between the particles, and in immediate contact with the trickling films of liquid, a current of air is constantly rising, being introduced at the bottom of the tank by a blower." His filter successfully purified the effluent from a preliminary strainer at the rate of 800,000 gallons per acre per day. The principle of oxidation of the organic matter employed in this filter is undoubtedly correct; the means of attaining this end, however, are rather involved and need close attention. A large-scale installation at East Cleveland, Ohio, had to be abandoned because of clogging and imperfect purification.

At this point, a brief mention will be made of the development of artificial biological methods in another direction. At Barking, England, a coke breeze filter three feet deep and covered with a three-inch layer of gravel was constructed by Binnie, Crimp, and Dibden.¹³ After unsuccessfully operating this filter by intermittent-continuous dosing, they obtained good purification on the fill and draw basis. This method of operation, known as contact filtration, has not been so generally adopted because the rate of filtration is only half that which can be obtained with the sprinkling filter and, hence, requires more area than the latter method. Contact filters are used to some extent for small installations where their comparative freedom from odors, and their ability to operate on a small head are real advantages.

Dibden,¹³ after some experimentation on contact filtration, constructed his well-known slate bed for the aerobic treatment of sewage. He claims that his bed will go far in reducing the amount of sludge obtained from sewage, by aerobically and inoffensively digesting it on the slates where it is originally deposited. These slate beds have not been adopted very generally because the additional removal of material does not seem to be at all commensurate with the cost of construction.

Lowcock,⁷ in 1892, filtered the effluent from a chemical precipitation process at Malvern through a gravel filter at the rate of 300,000

gallons per acre per day. He also used a fine surface layer of gravel to distribute the sewage. Hence in order to maintain aerobic conditions, compressed air was forced into the lower layers of the filter through perforated pipes. A satisfactory effluent was produced, but the cost of compressing the air was too high to warrant extensive adoption of this type of filter. Furthermore, a very serious objection to this and to Waring's filter is the difficulty of securing an even distribution of air throughout the entire filter bed.

In 1892, the Lawrence Experiment Station⁸ constructed two gravel filters using a forced downward draft. Sewage was applied at the rate of about 500,000 gallons per acre per day. Two similar filters were constructed in 1895⁹ and operated at rates of 698,000 and 1,000,000 gallons per acre per day. Good nitrification was obtained and the effluents were stable.¹⁰ During the course of the experiments, the amount of aeration was gradually reduced until a minimum of two hours aeration a day was reached. The principle of forced aeration was abandoned later, and all subsequent filters were built to receive only natural aeration.

In 1893, J. Corbett,¹¹ borough surveyor of Salford, England, was confronted with the necessity of finding some means of treating the sewage of the rapidly growing population of that industrial town. As neither irrigation nor land filtration could be adopted, he turned to artificial filtration for a solution to his problem. He based his work on the early Lawrence experiments which verified Frankland's principle of allowing the liquid to trickle away freely. Appreciating the importance of even distribution of the sewage, he directed all his efforts towards finding the most satisfactory method for sewage distribution.

At first he used wooden troughs for distributing the sewage. Later he raised these troughs several feet above the surface of the bed to let the sewage fall on the filter in a shower. He also constructed a filter in several units, or layers, having air spaces between the layers. The sewage in passing through the filter dropped from one of these units to the next in the form of a rain. This arrangement, however, seemed to give less satisfactory results than that having the filtering medium in one compact body. Still later he used rotating sprinklers, and finally, in 1894, he adopted the fixed spray jet which has become the most widely used method of distribution for sprinkling filters.

At about the same time that Corbett began his experiments, Wallis Stoddart¹² of Bristol described an apparatus for purifying

sewage, based on the trickling of sewage over coarse material with natural aeration. He exhibited his apparatus before the British Medical Association of 1894. It consisted of two burettes filled with coarse chalk and placed one directly under the other. The sewage was allowed to drip on the chalk in the upper burette and trickle successively through the two burettes. Sewage so treated was completely nitrified when applied at a rate of 1,200,000 gallons per acre per day and was well purified at a rate of 5,800,000 gallons per acre per day. A solution containing 140 parts per million of nitrogen in the form of ammonium sulfate was almost completely nitrified when used at a rate of 11,600,000 gallons per acre per day.

With only a small but constant trickle of sewage falling on the coarse chalk, the interstices were never filled with sewage to the exclusion of air. The sewage percolated in thin films over the chalk, always in contact with the interstitial air. These were precisely the conditions which the Lawrence Experiment Station had proved to be essential in continuous filtration. Stoddart pointed out that the exceptional activity of his filter was due to the regular and continuous flow combined with perfect aeration.

Stoddart maintained that Frankland's principles alone formed the basis of his filtration experiments and that he was in no way influenced by the work of the Lawrence Experiment Station. He even asserted that the Massachusetts data had been of no importance in the development of the coarse-grained filter. This statement has been refuted, however, by Dunbar¹³ who gives proper credit to the Lawrence work. Stoddart's claim on priority in continuous percolating filtration cannot be upheld, for Corbett's experiments were well under way in 1893 when Stoddart published his first paper. By continuous percolating filtration is meant the filtration of sewage through a coarse medium at relatively high rates. This term is used in opposition to intermittent filtration, where the sewage is applied to the land or sand at intervals of a few days. In the so-called continuous filtration the sewage is applied to a coarse medium at intervals of only a few minutes.

In 1899, Stoddart constructed a large filter at Horfield, using corrugated perforated plates to effect distribution of the sewage. Sewage flowed through the holes in the plate and thence along the under surface until it reached numerous small projections, from the lower points of which it fell on the bed in drops. The distribution and purification were good, providing the plates were perfectly level. The difficulty of keeping the plates level and of preventing growths in the perforations renders this method of distribution of doubtful practical value.

Dunbar,¹³ in 1901, worked out the so-called Hamburg type of trickling filter for the treatment of small amounts of sewage obtained from institutions. He used twenty inches of 0.04- to 0.12-inch material on top, then four inches of 0.12- to 0.4-inch material, and then four inches of 0.4- to 1.2-inch material over the coarse material of the filter. The distribution was effected by this fine layer of material, and clogging could be remedied by occasionally turning over the upper six inches with a shovel and resting the bed for a day or two.

Many other devices have been suggested for distributing the sewage over a filter. Most of them have not been widely adopted in this country and will only be mentioned to show the trend of experiments in this field. Garfield, in 1896, used fixed perforated pipes fed by a siphon. Later the pipes were made movable; first, about a center and, finally, to cover a rectangular area. Whittaker and Bryant, in 1898, used rotary sprinklers fed by a pulsometer pump which also served to warm the sewage. They attached much importance to the heating of the sewage, but later experiments at Leeds have shown that heating has no advantages. Candy, in the same year, used a rotary sprinkler differing from the previous one by being fed from a vessel at the junction of the distributing arms. Mather and Platt used open rotating troughs in an attempt to avoid the shortcomings of perforated pipes. Scott-Moncrieff used a motor-driven rotating open trough. Although the distribution was excellent, the cost was prohibitive. Travelling distributors operated by electricity or by overdriven water-wheels have been used to some extent in England. Ducat built a filter having walls of nearly horizontal drain-pipes to aerate the bed. In addition to providing for as complete aeration as possible, he supplied external heat to aid in the purification.

Such, in brief, has been the gradual evolution of the sprinkling filter as we know it today. The principle was discovered by Frankland; the coarse-grain filtering medium was introduced by the Lawrence Experiment Station; and the fixed spray jet was invented by Corbett.

We are indebted to Mr. Kenneth Allen, Sanitary Engineer of the City of New York Board of Estimate and Apportionment, for the following additional information concerning the history of trickling filters:

"1. The small plant installed October 25, 1897, by Scott-Moncrieff, consisting of a tier of trays containing coke, etc., through which septic effluent was passed with a remarkable increase in nitrites and nitrates due to the selective development of bacteria on the different trays. The

passage through the plant took but 8 minutes. (See Jour. San. Inst. Vol. XIX, Part 4. Also, Appendix I, Rep. Baltimore Sewerage Commission, 1899, and "The Polytechnic" Sept. 1890,—college periodical of the Rens. Polyt. Inst.)

"2. The old Reading, Pa., sewage filter. This received sewage that had been strained through coke and consisted of 10 beds of sand and cinder supported by a platform of " pipe. The sewage was delivered to semicircular galvanized troughs 6" diam. x 4' apart from which it overflowed to wooden gratings on which iron plates were placed to aid distribution and prevent scour. These beds were dosed intermittently, the sewage dropping through a space of about 10 ft. as a shower to a lower filter of sand on slag resting on concrete. The rate of filtration was about 7 mgd. per acre of each filter. The effluent was excellent in appearance but as the upper filter was supported on a steel structure the first cost was high and the plant was abandoned some years ago. It was, however an interesting attempt to apply the principles governing purification as then known. (See Appendix H, Rep. Baltimore Sew. Com. 1899. Also Eng. News, Jan. 27, 1928.)"

THEORY OF PURIFICATION BY THE SPRINKLING FILTER

General Considerations.—The effluent from a sprinkling filter presents a marked contrast to the sewage with which the filter is treated. The improvement makes itself evident first of all by the appearance of the samples. The settled sewage applied to the filter is quite turbid and milky in appearance, whereas the settled effluent is clear and almost free from turbidity. The effluent contains about as much filterable suspended matter as the sewage itself, but of an entirely different character. The brownish flocculent material in the effluent settles out quite readily, leaving the supernatant liquid clear. Sewage solids, on the other hand, will not settle because of their colloidal nature, and are hard to remove even by laboratory filtration methods. Lederer¹⁴ has found that the finely divided, slow-settling suspended matter and pseudo-colloidal matter cause most of the putrescibility of raw sewage. The chemical nature of the effluent solids is such that they are far more resistant to biological decomposition than the fresh sewage solids.¹⁵ Buswell¹⁶ has illustrated the progress of this change from putrescible matter to stable organic humus by means of a spiral (Fig. 1).

At *A* in Fig. 1, we have the soluble and colloidal organic matter in sewage. The bacteria and higher forms of life in the filter feed on this matter and convert it into the living protoplasm of their bodies. This point is represented by *B* on the spiral. These or-

ganisms form carbon dioxide, ammonia and nitrates for awhile and finally die, bringing the process around to point A.¹ The distance from A to A,¹ then, represents the combustion, or "wet-burning," of the organic matter from which the bacteria, protozoa, etc., have secured energy for their vital functions. Other cycles follow, as represented in the spiral, until a point near the center is reached. At this point, the available food material has been worked over by the successive generations of organisms so completely that not enough carbon and nitrogen are present in the proper form to support further life. This highly resistant residue, which sloughs off the stones¹ at intervals, forms the bulk of the sediment in normal filter effluents.

Chemical analyses of the sewage and effluent reveal still greater differences. The raw sewage shows relatively large amounts of free ammonia and albuminoid nitrogen, organic nitrogen and "oxygen consumed." Nitrates, nitrites and dissolved oxygen are present in very small amounts, if at all. On the other hand, the settled filter effluent is low in free ammonia and albuminoid nitrogen, organic nitrogen and oxygen consumed. Nitrates, nitrites and dissolved oxygen are present in fairly large amounts. These conditions give to the effluent its "stability," or resistance to putrefactive decomposition.

Nitrogen Cycle.—One of the characteristics of the filtration process is the conversion of putrescible nitrogenous matter to stable mineral salts. This change of nitrogen from one type of compound

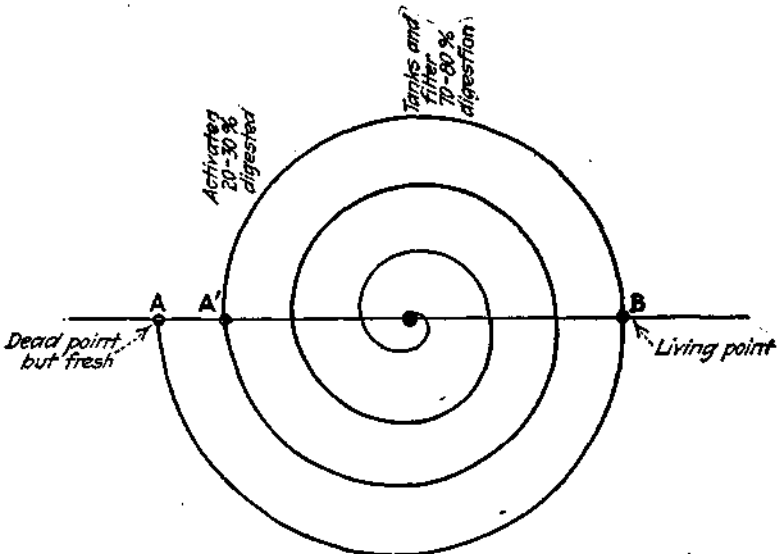

FIG. 1.—SPIRAL ILLUSTRATION OF THE CYCLES IN DIGESTION OF SLUDGE.

to another has been represented by the well-known nitrogen cycle.¹⁷ Because of the inclusion of death and the resultant irreversibility of the processes in this cycle, Buswell¹⁸ proposed a new nitrogen cycle to represent the changes occurring in sewage purification (Fig. 2).

In the sprinkling filter, the summation of the reactions is represented in Fig. 2 by arrows 1, 3, 5, showing the final production of

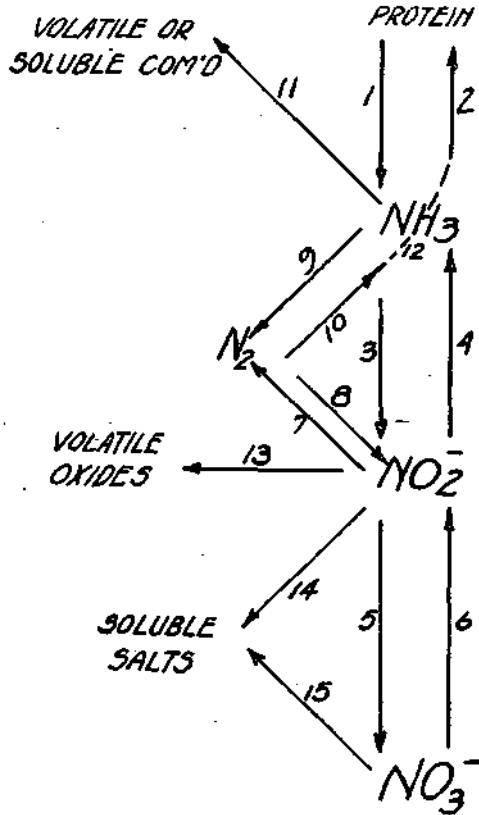

FIG. 2.

nitrate. It is well known that many organisms form ammonia from protein matter,¹⁷ and the researches of Robinson and Tartar¹⁹ have shown that this takes place first by the splitting of the protein molecule to simple amino acids. Then, by hydrolysis, reduction or oxidation, the amino groups of these acids are liberated in the form of ammonia. The formation of nitrite from ammonia is accomplished

by specific organisms like nitrosomonas. Nitrate is then formed from nitrite by such specific organisms as nitrobacter. Winslow and Phelps²⁰ have presented curves to show the dependence of nitrate formation on nitrite formation in sprinkling filters.

Mumford²¹ explains the mechanism of nitrification by the oxidation of ammonium salts in several stages. Hydrogen atoms are successively hydroxylated, with the subsequent elimination of water from the molecule. In support of this theory, he has found hydroxylamine salts and salts of hyponitrous and nitrous acid in the reaction mixture during the oxidation. Any nitrogen loss as gaseous nitrogen is due to the interaction of the intermediate products. Furthermore, since the relative concentration of these intermediates is dependent upon aeration, we have an explanation of the differences in nitrogen losses from contact and sprinkling filters.

Clark and Adams²² have shown that nitrification ceases when the carbon-to-nitrogen ratio in the sewage becomes too great. Good purification and production of a satisfactory effluent can be secured, nevertheless, if the filter is gradually accustomed to such sewage by the application of increasingly larger doses.

That the reverse reactions represented in the diagram by arrows 7, 9 may take place, has also been reported by Chick,²³ who found that some nitrogen was lost in trickling filters as gaseous nitrogen. Chick did not take into account, however, the nitrogen used in building up the microbial growth on the stones as would be represented by arrows 6, 4, 2. Similar omissions were made by Adeney,²⁴ and by Muntz³ and Laine.²⁵ From a survey of the literature on this question, Buswell¹⁸ has concluded that there are "no data in the literature - showing that nitrogen gas is formed to any great extent during the reactions of sewage purification. The forms of nitrogen left undetermined by the earlier experimenters would probably have accounted for most of the loss." In some activated-sludge experiments, he obtained a balance between the nitrogen in the influent and the sum of the nitrogen in the effluent and the sludge drawn from the tanks. This further supports the statement that nitrogen does not seem to be lost as the gaseous element in sewage purification reactions.

Rudolfs,²⁶ however, states that in all probability denitrification goes on continuously and simultaneously with nitrification in a sprinkling filter, but becomes apparent only when it exceeds the latter. This occurs in the spring just before the bed begins to "unload."

Theories of Purification.—The earliest theory advanced to explain the mechanism of purification was based on the Lawrence experiments with intermittent sand filters. According to this theory, the suspended solids in the sewage are mechanically strained out by the fine pores of the filter. This feature of the theory can only be applied with reservations to the action of the coarse-grained filter. The suspended matter so held in the filter is gradually oxidized, leaving a small residue of humus-like material. Organic matter in solution (and presumably pseudo-solution) is oxidized and mineralized directly by bacterial action during its passage through the filter. This simple view of the mechanism of the process was generally accepted even as late as 1909.

The Dunbar Absorption Theory.—As a result of a series of experiments extending from 1897 to 1900, at the Hamburg Hygienic Institute, Dunbar¹³ advanced his "absorption theory" of sewage purification. According to Dunbar, it was not possible for the organic matter to be completely oxidized to nitrate in the short time of passage through the filter; the mechanism was more complex than that. By way of explanation, it may be stated that absorption as used by Dunbar bears a closer resemblance to adsorption as we know it today than to true absorption.

According to the absorption theory, the important factors in the purification are the mechanical action of the filter, absorption, chemical combination, condensed oxygen, enzymes, micro-organisms and higher forms of plant and animal life. Mechanical action and absorption cause the fixation in the filter of the putrescible organic matter. Chemical combination also aids in this process to a limited extent, but is more generally associated with subsequent changes in the absorbed substances. The last three factors mentioned above are concerned with the later decomposition of the retained solids.

Suspended matters are arrested to some extent by fine pores in the filter medium but far more effectively by the slimy bacterial film which accumulates in a mature filter. This film consists principally of "organic matter, of humus material like colloids, which forms a honeycombed network possessing the properties of a sponge." The film or coating has an extraordinarily large surface and the liquid adhering to the outer surface, as well as the interstitial liquid, is under great pressure. Only those substances, the solubilities of which increase with pressure, are absorbed by the surface film; all others, of which sodium chloride is an example, pass through the

filter unabsorbed and unchanged. Thus, the mineralized products formed on the outer surface of the film diffuse into the succeeding dose of sewage because they are more soluble at the lower pressure of the sewage (viz., atmospheric pressure) than at the enormous pressures obtaining in the film.

These phenomena are due to the attainment of natural equilibria which can best be explained by absorption. Absorption would cease with the establishment of equilibrium; but in a biological filter this condition is never attained, because of the continuous action on the absorbed substances by bacterial and biological life in contact with atmospheric oxygen. Thus the equilibrium involving absorption, oxidation and diffusion of mineral salts is maintained in the bacterial film. This theory explains the need for intermittency in purification processes on the basis of the time necessary to decompose and oxidize the absorbed organic matter. A residue consisting of organic matter which is highly resistant to further oxidation gradually accumulates in the filter and is discharged at intervals in the effluent.

The Hampton Doctrine.—After studying the relation of sewage colloids to sludge production in filters at Hampton, England, Travis²⁷ advanced the Hampton Doctrine to explain the mechanism of purification. This theory states that the purification process is essentially a de-solution phenomenon effected by physical forces within the filter. The solid substances which had been disintegrated and dispersed in the crude sewage are physically reflocculated and collected in the filters, allowing the clear liquid to pass on. The doctrine emphatically denies the importance of bacterial or biological factors and states that any such action is "definitely ancillary to the purification process." Suspended matters are arrested by the pores of the filter, and by adhering to the filter medium and the bacterial slime which accumulates in the mature filter. Such retention is mechanical. Colloidal solids are deposited on the film in virtue of a physical operation, while soluble organic substances, ammonia, hydrogen sulfide and volatile products are all absorbed by the film. The fixation of these substances on the bacterial film is a physical action due to the ability of the film to concentrate colloidal and dissolved molecules in that layer of solution which is in immediate contact with the film itself. Volatile products are retained in a more or less insoluble and non-volatile state. Salts of ammonia and the alkalis can also be adsorbed after a preliminary chemical change. The degree to which this de-solution effect is carried is dependent upon

the effective surface and the amount of accumulated solids in the filter. The finer the particles and the more choked the bed, the better becomes the effluent. The added amount of sludge formed by the coagulation of colloids accumulates in the filter or is discharged in the effluent. In either event, the biolytic action is so slow as to be negligible and the sludge accumulation in the bed then becomes the total of the suspended matter in the applied sewage plus the colloidal solids precipitated within the filter, and termed by Travis "ultra-sludge."

Much polemical discussion on these conflicting theories has appeared in the literature. The papers by Travis²⁸ and by Lubbert²⁹ are especially to be recommended for a thorough study of the differences between the theories. Chick,²³ Fowler and Gaunt,³⁰ and Stoddart³¹ have shown that ammonium salts are not absorbed under sterile conditions except with clinkers or with material which allows of chemical combination. Stoddart also found the same to be true with albumin. Such data, however, should not be used to disprove the absorption theory, because with sterile substances, an equilibrium is quickly established and absorption comes to a standstill. One of the essential features of the absorption theory as Dunbar postulated it, is the existence of a dynamic equilibrium in which bacterial action plays an important part.

To sum up the evidence which is available at present, Ardern³² makes the following statements. Stoddart's experiments designed to show the direct oxidation by bacterial action of the organic matter in colloidal solution are not conclusive. But on the other hand, Clifford³³ and Tatham³⁴ have shown that under favorable conditions, the time of passage of the sewage through the bed may be long enough to allow of some direct oxidation. Although it may be true that sewage colloids are coagulated and precipitated by surface action, this de-solution theory cannot explain the entire phenomenon, since such physical actions would continue in the absence of micro-organisms. The conditions obtaining in a mature and efficient filter are such that absorption phenomena play an important part in the removal of matter from colloidal solution.

Proposed Concepts of Mechanism of Purification.—In the light of recent developments in the field of colloid chemistry, it is felt that certain of the phenomena in the purification process can be explained on a more rational basis. The correct interpretation of the phenomenon of adsorption will undoubtedly throw much light on the

mechanism of purification, and as W. C. McC. Lewis says, "There can be no doubt that more complete information of this purely physical phenomenon is the first step towards a rational understanding of the more complicated phenomena of the dye-house and the filter-bed." It is believed that such indefinite terms as "enormous pressures" and "absorption" used by Dunbar, and such vague terms as "de-solution" and "physical forces" used by Travis can be replaced by a more exact analysis of the fundamental principles underlying the whole process of purification.

As postulated in the older theories, coarse suspended solids are arrested and held by the slimy bacterial film. Such action is attributed to the gelatinous nature of this growth and to the formation of fine pores by adjacent films, through which large particles cannot pass. However, the growth which accumulates in a mature filter is characterized by an extremely large surface area, and hence exhibits, to a maximum degree, the surface phenomenon of adsorption, which will be discussed later.

Gibbs³⁵ has determined, from thermodynamical considerations, that, when a change in surface tension takes place due to the formation of a solution, a change in concentration also occurs, the surface film having a different concentration from the main portion of the solution. Film concentrations tend to change so as to decrease surface tension. In other words, if a solute increases the surface tension of the solution, the film will be more dilute than the main portion of the solution; if it decreases the surface tension, then the solute will concentrate in the surface film. The rule is expressed mathematically by the equation:—

$$C = - \frac{c}{RT} \cdot \frac{ds}{dc}$$

Thus, when the surface tension decreases with increasing concentration of solute $\left(\frac{ds}{dc} \right)$ the concentration of solute (C) in the surface layer, is positive and hence greater than in the main body of the solution. Freundlich³⁶ gives the complete thermodynamic derivation, which need not be reproduced here.

Most salts and all strong bases increase the surface tension of water; but ammonia, nitric and hydrochloric acids decrease it,³⁷ Gibbs' rule applies only to substances in true solution, but a similar

phenomenon has been found to occur in colloidal solutions. Many substances like soaps and proteins form colloidal solutions which have lower surface tensions than pure water.³⁸ Ramsden³⁹ found such substances to concentrate in the surface film. Our interest in these substances arises from the fact that such organic material must be removed from sewage in order to destroy its putrescibility. It has been shown by Willows and Hatschek⁴⁰ that surface concentrations of such colloids as Congo red, methyl orange, etc., are twenty to one-hundred times as great as those calculated from the formula. No expression has been derived to cover the behavior of colloids in this respect.

In sewage, we have colloidal soaps and proteins which tend to concentrate in a surface film as pointed out above. This need not be only the air-liquid interface, but can be the interface between the bacterial jelly and the sewage. For example, Donnan and Lewis,⁴¹ "in using oil drops to measure surface concentrations of colloids, obtained some results which showed large discrepancies from the calculated figures. They ascribed this to colloidal gelatinization or flocculation on the oil surface and stated that it may be regarded as excessive adsorption due to the marked lowering of the surface tension, resulting in the overstepping of the solubility of the solute and the consequent flocculation on the surface layer.

The substances which concentrate at the jelly-sewage interface are attacked by the bacterial and biological life of the jelly. As rapidly as these substances are removed by digestion, others come to the interface until the surface tension is reduced to its previous value. Thus a dynamic equilibrium is maintained between the removal of organic matter from the interface by digestion, and the addition of more organic matter to the interface by virtue of surface tension lowering.

Soluble products, such as ammonia, which lower the surface tension of water, obey Gibbs' rule closely and therefore concentrate at the interface. Because of their solubility, they may also be removed by direct preferential absorption into the living cells present in the jelly.

The bacterial film or jelly always contains dissolved and probably adsorbed oxygen, obtained chiefly from the air drawn into the bed, but to some extent from that dissolved in the incoming sewage. In the presence of oxygen, bacterial and biological agencies decompose the organic matter, with the final production of nitrate, carbon dioxide and a humus-like residue. It is certain that enzymes play an important part, at least in the initial states of the decomposition

of proteins.⁴² Nitrates raise the surface tension of water and are therefore driven away from the interface into the main body of the liquid and thus pass out of the filter. The humus remains on the stones and materially increases the effective surface. Salts like sodium chloride pass directly through without being adsorbed, since they raise the surface tension of water and do not concentrate at the interface. The fallacy of using sodium chloride to determine the detention period of organic matter in a filter will be more fully discussed later.

The ammonia originally adsorbed from the sewage, together with that formed in the decomposition of protein by bacterial activity, may undergo at least one of several fates. It may be used in the formation of living protoplasm by bacterial cells; it may be oxidized to nitrates by bacteria in order to meet energy requirements; it may be oxidized by organized or unorganized catalysts. When the adsorbed ammonia and oxygen meet on the film, we have conditions similar, to those existing in the oxidation of organic substances in the presence of a catalyst possessing enormous surface area. It is not unreasonable, then, to postulate the catalytic oxidation of ammonia on the bacterial films. Since the amount of nitrate in the filter effluent represents only about fifty per cent of the ammonia in the sewage, it is evident that the differences between the sum of the nitrate and ammonia in the effluent, and the ammonia in the sewage, must be accounted for by some other reactions.

Intermittent Action.—That there is a need for intermittency in dosing a filter is shown by the following considerations. Particles of organic matter concentrated at the interface of the jelly and sewage are liquefied by enzymes. They are then taken into the living cells at a rate dependent upon the utilization of these substances inside the cells. Since the predominant reactions in a filter are oxidations, this utilization depends largely upon the amount of oxygen available for this purpose. Thus the absolute amount of oxygen available, as well as the oxidation potential, regulates the oxidation of substances in the cell. This, in turn, regulates the rate of entry of organic molecules into the cells. Finally, dependent on this rate, is the rate of concentration at the interface. Hence the more oxygen available, the more colloids can be concentrated at the interface, dissolved, diffused into the cell and finally oxidized.

Since one liter of saturated water at 20° G. contains about 8 milligrams of dissolved oxygen, and one liter of air contains 250 milligrams of oxygen, it can be seen that a given quantity of air in

contact with the bacterial jelly contains thirty-one times as much available oxygen as the same quantity of saturated water or sewage. Furthermore, as it is being dissolved or adsorbed by the jelly, the diffusion of more oxygen molecules to the jelly is far more rapid through air than through sewage, since diffusion rates depend largely upon the viscosity of the media. If a continuous flow of sewage is allowed to trickle over the jelly, the necessary oxygen must come from that dissolved in the sewage. The intermittent sand filter is a very good illustration of the fact that there is not enough oxygen in solution in sewage to permit purification. We have secured some data which point to the same conclusion.

On the other hand, when intermittent dosing is employed, air is drawn into the bed to replace the receding sewage. With the far greater amount of oxygen thus introduced, and the higher rate of diffusion to the jelly, the necessary oxygen is rapidly absorbed. The activated-sludge process illustrates the fact that, as more oxygen is furnished, the amount of nitrification increases.

Progress of Purification.—An insight into the probable progress of purification at different depths of the filter can be gained by a brief consideration of several related phenomena. One of these is the law of mass action, or law of molecular concentration, which states: in every chemical change the apparent activity, and therefore the speed of the action, is proportional to the molecular concentration of each interacting substance.⁴³ In other words, the rate of a reaction increases with increasing concentrations of reacting substances. With this established law in mind, it is not unreasonable to expect greater removal of ammonia and colloids by the upper part of a filter where they are more concentrated than at any other point in the bed. As the sewage trickles through the filter, these substances are removed, the concentration is lowered and hence the reactivity or rate of removal should be reduced. We would predict that an equilibrium should be reached at some depth beyond which the degree of purification is increased only very slightly, if at all. Furthermore, the purification of sewage in a filter is due to biochemical reactions which, in common with most expressions dealing with vital activity, cannot be considered as simple linear functions of time. The commonest example is the work of Chick,⁴⁴ which indicates that in disinfection the death rate of bacteria is proportional to the number of living cells at any given time. With certain limitations, the process follows a logarithmic expression similar to that for adsorption, a first-order chemical reaction, rate of solution,

etc. In a later section are presented biochemical-oxygen-demand data which also show that processes dependent on vital activity do not vary directly with time.

The removal of ammonia by activated sludge further illustrates the manner in which reaction rate is affected by concentration. Bartow and Mohlman⁴⁵ found that 52 per cent of the ammonia was removed in the first hour of aeration and only about 18 per cent in the second hour. The rate gradually dropped off until, during the fifth hour of aeration, no more ammonia was removed. If we apply these data to the sprinkling filter, we can use depth of bed instead of time of contact with the growth, since the distance covered by the liquid in trickling down through the bed is proportional to time. Because of the analogy between the two processes, we might well expect a greater removal of ammonia in the upper part of a filter bed where the concentration is at a maximum. This has been found to be true, and curves showing ammonia removal in a filter bed are similar to those showing ammonia removal by activated sludge.

In virtue, then, of theoretical reasoning on the basis of the law of mass action, and of practical evidences of the applicability of this law in similar processes involving living cells, the current practice of assuming an equal degree of purification by each foot of filter depth is questionable. The data secured in this investigation confirm our belief that the upper portion of a filter is far more effective than the lower-portion.

Summary of theoretical discussion.—Our conception of the mechanism of the purification process may be summed up briefly:

1. Colloidal and soluble substances which lower the surface tension of water concentrate at the jelly-sewage interface.

2. These adsorbed substances are attacked by enzymes, bacteria and higher forms of animal life, and the ammonia thus liberated is subsequently oxidized by bacterial or chemical means.

3. A flocculent, humus-like residue of large surface area accumulates in the filter until the semi-annual unloadings.

4. Since sufficient oxygen for the oxidation reactions cannot be obtained from that dissolved in the sewage, it is necessary to operate the beds intermittently to cause atmospheric oxygen to come in contact with the bacterial film.

5. The application of the law of mass action and the consideration of the phenomena of adsorption and related biological processes lead to the hypothesis that the bulk of the purification is effected in the upper part of the filter where the sewage is most concentrated. The present work is a study of the validity of this hypothesis.

REVIEW OF PREVIOUS WORK ON THE RELATION OF DEPTH TO DEGREE OF PURIFICATION

Early English Data.—This important problem of the relation of the depth of filter to the degree of purification has received much attention in the past. In 1897, at Accrington, England, Whittaker⁴⁶ found that a nine-foot bed gave better purification and higher nitrification than a six-foot bed constructed of the same material and receiving the same quantity of septic tank effluent per square yard of surface area. His original data not being available, no figures can be given here as to the actual results obtained from each filter.

In 1900, Harding and Harrison⁴⁶ caused crude Leeds sewage to trickle successively through three separate layers of coarse coke, three and a half, two and a half, and two and a half feet deep, respectively. Their data showed that the purification effected by the third layer was not proportionately as great as that accomplished by the first. Their results, given in Table I, furnish some of the earliest evidence pointing to the greater purification effected by the upper layers of a filter.

TABLE I.*

Results Expressed in Grains Per Gallon.

Source	Free ammonia nitrogen	Oxygen consumed	Nitrate nitrogen	Suspended solids
Crude sewage.....	2.36	8.90	44.2
3'6" filter.....	1.58	4.37	19.2
2'6" filter.....	1.15	2.78	7.9
2'6" filter.....	0.83	1.93	0.14	7.7

* From Harding and Harrison.⁴⁶

Bell,⁴⁶ in 1900, treated three filters of medium-sized clinkers with the effluent from chemical precipitation at Salford, England. The filters were three, five and eight feet deep, respectively, and received the same amounts of sewage per square yard of surface area. His results indicate that 64.5 per cent of the nitrification was completed at a depth of three feet, which is only 37.5 per cent of the total depth of eight feet. Although he obtained better purification in the deeper filters, the increase was by no means proportional to the depth. The upper layers of the filter accomplished a greater portion of the purification than the lower layers, as can be seen from Table II.

TABLE II.*
Results Expressed in Grains Per Gallon.

Source	Free ammonia nitrogen	Oxygen consumed	Nitrate nitrogen
3-foot filter.....	2.6	1.1	.84
5-foot filter.....	2.4	0.8	1.10
8-foot filter.....	2.2	0.5	1.30

* From Bell.⁴⁶

Beginning in 1903, the Eoyal Commission on Sewage Disposal⁴⁶ carried out experiments at Horfield and Ilford, England, dosing coke filters of different depths with equal quantities of sewage per cubic yard instead of per square yard. The results obtained at Ilford with filters three and six feet deep are given in Table III.

TABLE III.*
Results Expressed in Parts Per Million.

	3-foot filter	6-foot filter
Rate (gals. per cu. yd. per day).....	125	125
Rate (gals. per sq. yd. per day).....	125	250
Ammonia nitrogen.....	35.5	29.2
Organic nitrogen.....	8.4	7.9
Nitrite nitrogen.....	1.5	1.3
Nitrate nitrogen.....	13.5	19.4
Oxygen consumed.....	30.9	31.2

* From British Royal Commission on Sewage Disposal.⁴⁶

From these results they concluded: "For practical purposes we think the conclusion is justified that, within somewhat wide limits of depth, and given ample aeration and good distribution, the same amount of work can be got out of a cube yard of coarse material whether it is arranged in the form of a deep or of a shallow percolating filter."

Modern Practice in Filter Design.—The design of most modern sprinkling filters rests upon the authority of the above conclusion. In the range of depths investigated by the Eoyal Commission (three to six feet) the purification per foot depth does approach a linear function more closely than in any other range. The assumption that the same linear relationship would hold at all depths was then made arbitrarily. In spite of the fact that theoretical reasoning borne out by some experimental results disproves this assumption,

filters are designed to treat sewage at a definite rate per acre-foot of filter medium, and, with the utmost faith in the Royal Commission's statement, the depth of the filter is largely determined by engineering and economic considerations. The cost of building one acre of filter ten feet deep is less than that of building two acres of filter five feet deep;⁴⁷ naturally, the cheaper arrangement of the same cubic content of filter is selected. Little attention is given to the question of providing the optimum conditions for the biological life within the filter; little thought is given to the importance of the law of mass action, one of the fundamental laws of chemistry; a filter is regarded as just so many cubic feet of stone. Until filters are designed primarily to provide the best environment for the living agencies of purification, and are not merely calculated to treat a definite amount of nitrogen per acre-foot of stone, the most efficient and economical results cannot be expected from sewage treatment plants.

In a pervious section (page 24) it was pointed out that more purification might be expected to take place where the sewage is most concentrated. This is well supported by Greeley⁴⁸ who has compiled data on sprinkling filter loading and has found that, as the concentration of organic nitrogen and ammonia in the raw sewage increases, filters can successfully handle larger amounts of nitrogen and ammonia. At a concentration of 25 parts per million, for example, a six-foot filter would handle 170,000 grams per acre per day; at 50 parts per million, 260,000 grams per acre per day could be treated. These figures, taken from actual operating records, further illustrate the foregoing principle, that the rate of reaction is proportional to the concentration of reacting substances. Although the fundamental basis of Greeley's curve is sound, his method of correcting all filter results to the basis of a six-foot bed is not in accord with the principle illustrated by his curve. Loadings for a ten-foot bed, for example, are converted to loadings for a six-foot bed by using a factor of six-tenths. Thus, in the same discussion, he points out that increased concentration causes increased activity and then virtually denies this statement by attributing the same effectiveness to each foot of depth. This mistake is frequently made and reflects a common but erroneous attitude toward biochemical phenomena.

Baltimore Data.—In 1911, the Baltimore Sewerage Commission⁴⁹ reported the results of experiments made in 1907-1908 to determine the most economic depth of filtering material consistent with a high

degree of purification. Each of two filter units, approximately one-eighth of an acre in area, was subdivided into six parts containing two beds six feet deep, two beds nine feet deep and two beds twelve feet deep. These four series of beds were made up of stones of different sizes ranging from one-half inch to six inches. Sewage was applied by rotating arms carrying nozzles; in this manner, the beds received sewage at the same rate per square yard of surface area. The results of the operation of these filters led to the conclusion that "the amount of purification per foot of bed decreases as the bed increases in depth, with the exception of nitrification which seems to vary almost directly as the depth of the bed." Curves showing the results bring out very graphically the fact that the six-foot filter, or presumably the upper six feet of the deeper filters, effected from sixty to ninety per cent of the total purification effected by the twelve-foot filter. The results for a filter of one- to two-inch stone are given in Table IV. These were taken from curves on page 60 of the Commission's reports.

TABLE IV.*

Depth in feet	Kjeldahl per cent reduction	Oxygen consumed per cent reduction	Relative stability	Nitrate nitrogen p.p.m.
6	33	56	79	9-
9	48	71	87	15
12	54	73	89	18

* From the Baltimore Sewerage Commission.⁴⁹

Philadelphia Data.—Experimental work carried out at Philadelphia⁵⁰ in 1908-1910 on filters of different depths led to the same conclusions as those reached at Baltimore. Six filters each two-thousandths of an acre in area and ranging in depth from three feet three inches to eight feet were treated with sewage at equal rates per square yard of surface area. From the data obtained (see Table V) it was concluded that "filters of less depth than six feet were not satisfactory, but from filters six feet or more in depth, effluent could be obtained at rates between two and a half and three million gallons per acre per day of satisfactory quality. The additional depth over six and one-half feet did not seem to be economical."

TABLE V.*—PER CENT REMOVAL FROM CRUDE SEWAGE.

Depth of filter	Free ammonia nitrogen	Nitrite nitrogen	Nitrate nitrogen	Oxygen consumed
3'3".....	48	—30	—94	27
4'3".....	48	—16	—143	27
5'.....	74	4	—164	36
6'.....	63	—41	—183	36
7'.....	72	—11	—160	41
8'.....	64	—15	—157	32

* From the Philadelphia Bureau of Surveys.⁵⁰

Lawrence Experiment Station Data.—Clark⁵¹ has done some important work on the general question of depth and efficiency of filters at the Lawrence Experiment Station. Attacking the problem from an entirely different angle from the work previously carried out, he endeavored to obtain the same quality effluent from filters of different depths by adjusting the rate of application of sewage. On May 1, 1913, four filters, respectively four, six, eight and ten feet deep, constructed of broken stone between three-quarters and one and one-half inches in size, were put into operation. Settled sewage was applied to each at such rates as to produce effluents containing approximately fifteen parts per million of nitrate. This criterion was selected because it had been found that fifteen parts per million of nitrate was necessary to stabilize effluents of filters receiving Lawrence sewage. Early in 1914 the filters had ripened and the rates were adjusted until effluents containing the predetermined fifteen parts per million of nitrate were obtained from all the filters. The rates are given in Table VI and are expressed in gallons per acre per day.

TABLE VI.*

Year	Nitrates p.p.m.	4-foot	6-foot	8-foot	10-foot
1914.....	15	332,700	585,100	1,801,000	3,733,000
1915.....	10	466,400	805,500	1,767,250	3,501,000
1916.....	10	410,000	931,000	1,471,500	3,837,000
1917.....	10	287,000	780,000	1,400,000	3,250,000
1918.....	20a	204,000	468,000	931,000	2,034,000

* From Clark.⁵¹

a Nitrates from the 10-foot filter were only 8 p. p. m.

These data indicate that, as the depth of the filter is increased, the rate at which sewage may be successfully filtered also increases, but at a more rapid rate. Clark explains this by the more perfect mixing of the applied sewage with the "held" water in the deeper filters. Previous work at the Station (1890) had "shown that when sewage is applied to a sand filter containing interstitial water, some of the applied sewage will pass the interstitial or held water instead of pushing it ahead and then appear in the effluent before much of the held water appears. This effect was more marked with coarse than with fine sand and is believed to hold equally well with a coarse-grained filter. By applying salted sewage to the four filters at the rate of one million gallons per acre per day, it was found that fifty per cent of the salt appeared in 12 minutes in the four-foot filter, in 18 minutes in the six-foot filter, in 48 minutes in the eight-foot filter, and in 105 minutes in the ten-foot filter. The disproportionately longer time of contact in the deeper filter was used as the explanation of the greater activity and the higher rates permissible.

The time of passage of liquid through a filter bed, as determined by the appearance of salted sewage in the effluent, must be interpreted with caution. It represents the time required for a certain portion of liquid to trickle through the bed and is the time of contact of that liquid with the bacterial film. It does not represent, however, the detention period of much of the organic colloids. In a previous section of this paper (page 26) it was pointed out that the soluble and colloidal organic substances found in sewage may be retained in the filter by surface tension phenomena until digested and mineralized by the organized life of the filter. This is not the case with substances which raise the surface tension of water, of which common salt is an example; these pass directly through the filter and are not absorbed in the same way as are the organic substances. As a result, organic matters remain in the filter in contact with the bacterial film for much longer periods than would be indicated by the time of passage of salt. The difficulties of obtaining data on the fate of one specific colloid particle in a filter are obvious. Clifford³³ and Tatham³⁴ have shown that the time of passage of liquid through a filter is sufficient to allow of some bacterial action. While this is undoubtedly true, it is difficult to conceive of such action bringing about nitrification of much ammonia and protein nitrogen in the relatively short time of passage.

Four filters similar in depth and construction to the original four were put into operation at the Lawrence Station on April 10,

1915. The filtering media consisted of much larger stones than those previously used. The results of operation were similar to those obtained before and pointed to the same conclusions.

As pointed out above, Clark was not attempting to trace the progress of the purification at the different levels of a filter bed and hence did not attack the depth problem from that standpoint. From the data secured up to 1919, it is impossible to correctly evaluate the relative abilities of the different layers of media. The use of different rates of treatment introduces such complicating factors as time of rest, amount of oxygen absorbed during this time, and time of contact with the film and thus destroys the possibility of using Clark's early results to indicate what changes are brought about in sewage at the different depths of a filter bed. By assuming equal purification per foot of depth it can be done, of course, and has been done by Clark with the result that in the deeper beds, the rate of treatment, and presumably the activity, per foot depth seems to be greater than in the shallow beds. This assumption and the conclusions based upon it are not justifiable, either theoretically or in the light of the practical experiences mentioned in the preceding pages.

In 1919, however, Clark⁵² operated each of the four filters at the rate of 1,368,000 gallons per acre per day and obtained results (see Table VII) which showed that the purification taking place below the six-foot depth was not at all proportional to the depth. These figures are in close agreement with the previously mentioned work and bring out very clearly the fact that the bulk of the purification is effected in the first six feet of the filter.

TABLE VII.*

Results Expressed in Parts Per Million.

Depth in feet	Ammonia nitrogen	Organic nitrogen	Nitrate nitrogen	Oxygen consumed
4	33.8	2.0	7.7	34.3
6	28.5	9.3	17.4	28.1
8	27.5	8.6	15.9	28.0
10	26.4	7.7	18.5	28.4

* From Clark.⁵²

Fuller⁵³ and Eddy⁵⁴ have exhaustively reviewed the results of operation of filters in different places and have championed the shallow and deep filter, respectively. They have compared data from many different plants by making assumptions and corrections for

strength of sewage, depth, loading, etc. Their work cannot be used in studying the problem of the progress of the purification process with respect to the various levels of a filter bed.

New Jersey Sewage Substation Data.—In January, 1922, the Sewage Substation of the New Jersey Agricultural Experiment Station⁵⁵ began a series of tests to determine some of the chemical changes brought about in sewage at different levels of a sprinkling filter. The first means of sampling used by them consisted of three holes, seven inches wide, eight inches high, and extending into the bed two feet. These holes were directly under each other at the one-three- and five-foot levels in the six-foot filter at Plainfield. Less than twenty sets of samples were taken from these holes from January to June, 1922, and from these the following conclusions were drawn: (1) . In the upper layers of the filter, nitrite and nitrate nitrogen were removed from the sewage during the early part of this period. At the same time there was considerable storage of solids within the filter and a maximum development of film. (2) The production of nitrite and nitrate in the body of the filter began after the spring slough was well under way and increased rapidly as the period of maximum slough approached. (3) There was considerable nitrite and nitrate production in the bottom layer of the filter for the entire period. (4) There was a greater amount of chemical change brought about in the bottom layer of the filter than in the upper layers. (5) Flooding the filter reduced nitrite and nitrate production.

These studies were continued for another year by Campbell and Rudolfs⁵⁶ using a different type of sampling device. Twenty-four-inch lengths of one and five-eighths inch galvanized pipes were sawed in half lengthwise for a distance of eighteen inches. One of these halves was sawed off, thus leaving an eighteen-inch trough to collect sewage. Two sets of three pipes were installed in the filter at different points with respect to one sprinkler nozzle and were placed in a vertical line at depths of one, three and five feet.

Values for nitrate and ammonia nitrogen were corrected for a so-called "sample-volume effect," which can be explained as follows: When the volume of sample exceeded the theoretically computed volume of two hundred cubic centimeters, then the time of contact of sewage with the film was thought to be less than the average, due to channelling. The amount of action was arbitrarily made directly proportional to the volume of sample and all values correspondingly

"corrected." For example, the theoretical volume was calculated to be two hundred cubic centimeters; if a flow of four hundred cubic centimeters and five parts per million of nitrate were found, then the flow was twice the theoretical; hence the time of contact was half the theoretical, and so was the nitrification; therefore, ten parts per million of nitrate was recorded. If the flow was low, then the nitrate value, for instance, was corrected to be less than the amount found.

This reasoning is hardly sound, since it implies that nitrification is directly proportional to time of contact of liquid with the film. In the first place, this would involve nitrification of nitrogenous substances during the time of passage of liquid through the bed, which is doubtful; and in the second place, it assumes that the biological reactions bringing about nitrification and removal of ammonia are straight-line functions of time, which has been repeatedly shown to be erroneous.

Based on observations corrected as outlined above, the following conclusions were drawn by Eudolfs: (1) The greater part of the effective nitrification takes place at the bottom of the bed throughout the whole year. It is believed that old solids which collect at the bottom offer a large, active surface to the sewage flowing through them and so are responsible for the nitrification at the bottom. There is thought to be some analogy to activated sludge. (2) In all probability, denitrification goes on continuously and simultaneously with nitrification, but becomes apparent only when it exceeds nitrification. Denitrification exceeds nitrification in the upper parts of the bed in the spring just before the accumulated solids pass out. (3) Free ammonia is removed chiefly at the bottom of the bed. Ammonia formation in the bed often obscures the decrease in ammonia originally present in the influent as it passes through the bed.

A tabulation of the nitrate values obtained at New Jersey does not support the conclusion that most of the nitrification takes place at the bottom of the filter. Working on the assumption that in a long-time experiment the average of many determinations will represent a true picture of average conditions at the various levels, we have obtained the averages given in Table VIII from the New Jersey data.

Thus, by making the very corrections which Campbell and Eudolfs recommend we get averages showing still less that the last few inches are important. On the other hand these averages tend to accentuate the greater purification brought about by the first five feet, and show that the rate was dropping off at the six-foot level.

TABLE VIII.*

Results Expressed in Parts Per Million.

Depth in feet	Nitrate nitrogen	Nitrate nitrogen (corrected)
0.....	.58	.58
1.....	.49	1.27
3.....	1.58	2.00
5.....	3.90	5.28
6.....	5.51	5.51

* From Smith.⁵⁵

Summary of Previous Work.—A survey of the previous work on this question of the progress of purification at different levels in a filter, makes it apparent that when filters of different depths are dosed at the same rate per unit of surface area, and the same volume of sewage trickles through the different filters, the rate of purification is greatest where the concentration of removable impurities is greatest, i. e., in the upper few feet of the filter. In experiments conducted on the basis of equal dosage per cubic yard, the results do not agree with those obtained on the basis of equal dosage per square yard. The reason for this will be apparent when the conditions are scrutinized more closely. If two filters of equal area and of four and eight feet depth, respectively, are dosed with equal amounts of sewage per cubic yard, then the deep filter will receive twice the total amount of sewage received by the four-foot filter. Hence, twice the amount of sewage will trickle over the first two feet, for example, of the deep filter as compared to the first two feet of the shallow filter. Naturally, being loaded to twice the extent, the first two feet of the deep filter do not purify sewage as well as the less heavily dosed two feet of the shallow filter, and the value of the upper portion of the filter is obscured.

If the progress of purification is to be studied in relation to the depth of the filter, then it is obvious that fair samples taken at different depths would furnish the data necessary to judge the degree of purification attained at the sampling depth. Because of certain inherent difficulties in such sampling procedure, different filters of various depths may be used. But it is necessary to have the sewage applied at the same rate per unit of surface area to each filter, just as is done in the case of the large filter with sampling devices at different levels. In that way, all variable conditions are eliminated,

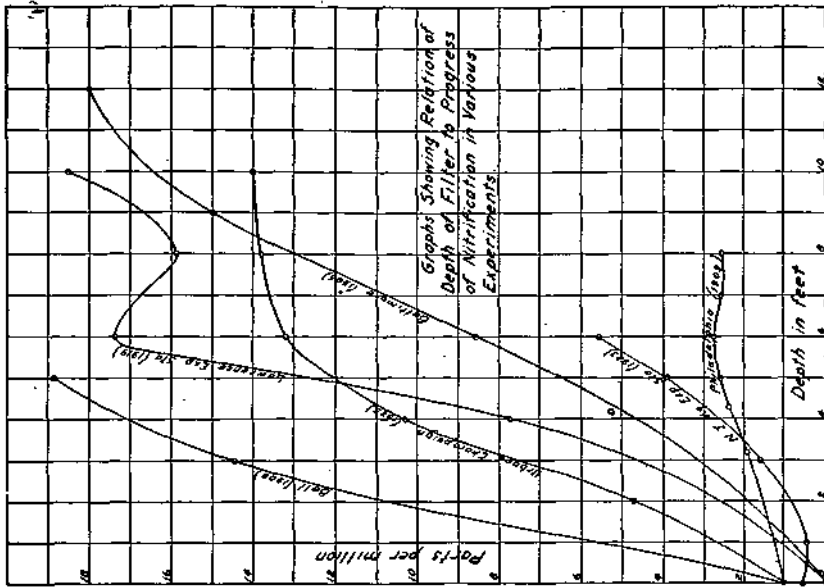

FIG. 4.

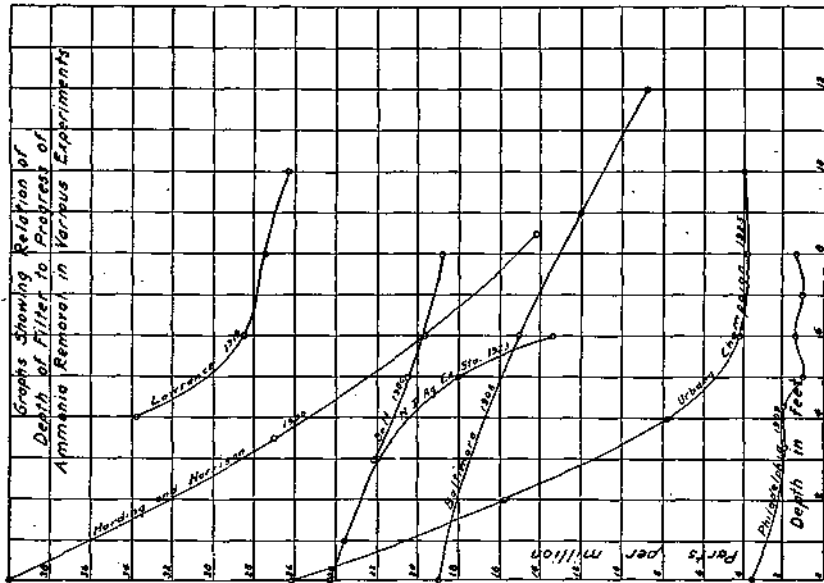

FIG. 3.

with the exception of those relating to the depth of bed through which the sewage trickles and the progress of the purification process can then be traced.

Figures 3 and 4 show graphical summaries of previous results obtained in a number of different experiments. For the sake of comparison, our results are also included.

EXPERIMENTAL PROCEDURE AND RESULTS

Description of Filter.—The experimental work was carried out at the treatment plant of the Urbana-Champaign Sanitary District, where the sprinkling filter installation consists of two units, each eight-tenths of an acre in area and ten feet deep. The construction of the underdrains and supports for the filter stones is shown in Fig. 5. It is of interest to note that the channels are lined with iron troughs which may be pulled out to remove any stones which fall through the tile supports.

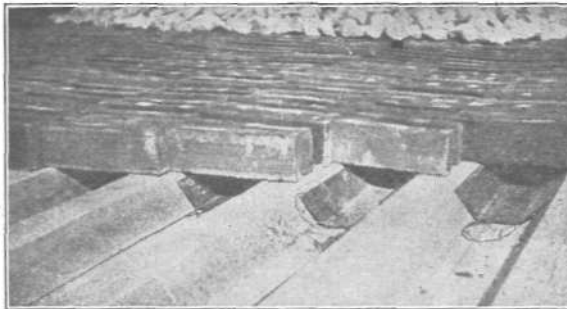

FIG. 5.—CONSTRUCTION OF UNDERDRAINS.

A six-inch layer of stones ranging in size from two and one-half to four and three-fourths inches rests on the tile supports as shown in Fig. 6.

Above this layer are laid about nine and one-half feet of stones of such size as to be retained on a screen having circular holes one inch in diameter and to pass through a screen having circular holes two inches in diameter. The total depth of the filter material is ten feet.

The sprinkler nozzles are of the Taylor type furnished by the Pacific Flush Tank Company. They deliver a circular spray. Some time after the plant had been put into operation, a new half-nozzle was designed for use along the sides of the beds.

Two dosing tanks, with a capacity of approximately thirteen thousand gallons each, provide for the alternate dosing of the beds. When one tank is filled, an automatic air-release causes the entering sewage to be diverted to the empty tank, and a siphon causes the full tank to be discharged. In this way, one tank is emptying while the other is filling.

Champaign-Urbana Sewage.—Champaign-Urbana sewage is an ordinary domestic sewage containing practically no trade wastes. It is settled in four Imhoff tanks before treatment by the filters. At the time these experiments were conducted, the detention period in the tanks was about four hours, due to the large tank capacity which had been calculated on the basis of the estimated sewage flow in 1945. Analyses of raw sewage, Imhoff tank effluent and filter effluent, extending over a period of one year, are given in Table XIX on pages 66 and 67.



FIG. 6.—TILE SUPPORTS AND BOTTOM LAYER OF LARGE STONES.

Sampling Pipes.—During the construction of the filters, four sampling pipes were installed in the east bed at depths of two, four, six and eight feet from the surface of the filter. The spacing of these pipes, shown in Fig. 7, was designed to allow sewage to trickle unimpeded from the surface of the bed to each sampling pipe.

The samplers were made by sawing five-foot lengths of cast-iron pipe in half lengthwise for a distance of two feet. Half of this portion was sawed off, making a trough two feet long and six inches wide at the top. A quarter-inch glass tube, three feet long, was laid on the bottom of the pipe, extending from the mouth to the beginning of the trough. The glass tube was imbedded in concrete for protection. The rear end of this concrete was raised in order to cause all the sewage caught in the trough to run through the glass tube, and

prevent it from running down through the open pipe. A layer of concrete one inch deep was poured into the trough and sloped toward the glass tube. A view of a completed sampler is shown in Fig. 8: Complete plans and diagrams are given in Fig. 18 (pages 76 and 77).

These sampling pipes were designed to eliminate the additional purification which would take place if the sewage flowed through the large pipe in free contact with air. A bacterial jelly would soon form in the pipe and the sewage in flowing over it would be purified in the same manner as in the bed itself. Such a sample would

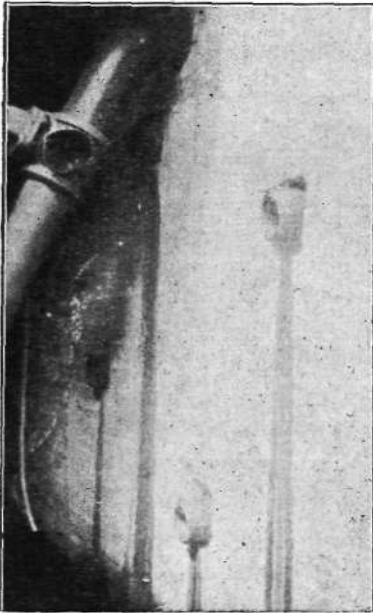

FIG. 7.—SAMPLING PIPES IN EAST FILTER.



FIG. 8.—SAMPLING PIPE.

obviously not represent the treatment effected by trickling from the surface to any one sampling pipe; instead, it would represent such treatment plus that effected by the flow over the growth in the pipe. With our device, the glass tube is completely filled by the sewage flow and hence receives no aeration; furthermore, the small, smooth glass tube can be kept free from growth more thoroughly than the large, rough iron pipe.

With the exception of composite samples collected for the plant operating records, all samples from the filter were grab samples, since it was not practicable to have composite samples collected from the sampling tubes. The procedure in sampling was to clean out the glass tubes by means of a wire and allow one spray to wash out any debris. Funnels, to which were attached rubber tubes, were then hung on the ends of the sampling pipes. One of these funnels may be seen hanging on the distribution pipe in Fig. 7. At the instant a spray began, the ends of the rubber tubes were put into four-liter bottles and allowed to remain there until the next spray began. In this manner the flow from one complete spray was obtained. The importance of obtaining the flow for a whole spray will be pointed out later. The volume of each flow was recorded in order to determine whether any relation existed between the volume delivered and the degree of purification effected. This relationship was discussed under the work of the New Jersey Agricultural Experiment Station. In the hope of obtaining a representative average sample of the effluent, samples were dipped from the gutter in the pipe gallery when the flow was about midway between minimum and maximum.

After sampling, the funnels and rubber tubes were taken from the pipes and hung up to dry. In this way no growth developed in the rubber tubing.

Analytical Methods.—Samples were taken to the laboratory where the analyses were begun at once. In no case did more than a few hours elapse before the analyses had proceeded to such stages that further delay would not cause decomposition of the samples. At first, all samples were shaken before analysis, but beginning with May, the turbidity determination was run on settled samples; and beginning with August, all determinations were made on settled samples, with the exception of suspended solids.

One of the functions of the filter is to change the putrescible organic matter to a humus-like residue which accumulates in the bed. Some of this is continually being sloughed off in varying amounts and its presence in the effluent obscures the work done by the bed in changing the nature of the organic matter. For example, the turbidity of an effluent containing much flocculent, rapid-settling residue may be as high as the turbidity of the applied settled sewage, which in the latter case is due to highly putrescible colloids. An inspection of the turbidity figures would show that no improvement had been effected by the filter and no account would be taken of the conversion

of colloidal to settleable matter. Hence, by allowing the residue to settle out and taking the supernatant liquid, we can more correctly evaluate the work accomplished by the filter.

The settling period was made one hour, because in that time all of the flocculent material which sloughed off the stones had settled out. Soluble constituents like ammonia, nitrate and nitrite are unaffected by settling, but turbidity, organic nitrogen, and oxygen consumed vary with the amount of settleable matter present. Although settling would alter the absolute value of these determinations, it does not affect the comparative data from the different levels secured over a long period.

All analyses were made in accordance with the standard methods of the American Public Health Association.⁵⁷ Distillation methods were used for free and albuminoid ammonia, total organic nitrogen, and nitrate nitrogen after reduction with aluminum strips and alkali. The nitrate values include nitrite nitrogen since both are reduced to ammonia by aluminum and alkali.

Several samples were collected a few days after the plant was put into operation in November, 1924, and a few more were taken during the winter. Systematic sampling was begun in March, 1925, and continued to the middle of November. The samples are grouped in several series, which will now be described.

Series A Samples.—Series A represents the twenty-four-hour composite samples collected every six days. Two hundred fifty cubic centimeter samples were taken every hour from the raw sewage after it had passed the coarse bar screen, from the Imhoff tank effluent, and from the filter effluent. Samples from six a. m. to five p. m. were put into the day-shift bottle and samples from six p. m. to five a. m. were put into the night-shift bottle. Chloroform was used as a preservative. Five hundred cubic centimeters were taken from each of the three day-shift bottles, mixed with five hundred cubic centimeters from each of the three night-shift bottles, respectively, and these three composite samples were used for analysis. The data thus show a weaker sewage than if samples proportionate to the hourly flow had been collected. Table XIX in the Appendix gives the analyses of these samples.

Table IX summarizes the most important data relative to the performance of the different units of the plant from December, 1924, to November, 1925, inclusive. Since the table gives per cent removals, negative values indicate negative removals, or additions. All percentages are based on the values found for the raw sewage.

TABLE IX.—PER CENT REMOVAL OF DIFFERENT CONSTITUENTS OF SEWAGE BY IMHOFF TANKS AND SPRINKLING FILTERS AT THE URBANA-CHAMPAIGN TREATMENT PLANT.

Based on values for the raw sewage.

	Turbidity		Gooch solids		Oxy. cons.		Amm. N.		Org. N.		Nitrate N.	
	Im. T.	Sp. F.	Im. T.	Sp. F.	Im. T.	Sp. F.	Im. T.	Sp. F.	Im. T.	Sp. F.	Im. T.	Sp. F.
Dec., 1924.....	50.0	66.5	69.0	77.5			0.0	0.0	21.8		10.0	20
Jan., 1925.....	22.4	72.2	51.2	77.8			2.2	10.3	-80.0	40.0	0.0	-212
Feb., 1925.....	28.6	61.9	52.5	79.1			0.0	0.0			0.0	-200
Mar., 1925.....	16.4	46.5	36.4	41.5	20.0	38.0	-7.5	64.8	-37.7	10.4	3.3	-127
Apr., 1925.....	8.4	35.8	56.7	14.2	15.6	46.7	-4.4	70.0	28.2	63.7	26.6	-800
May, 1925.....	35.0	82.0	56.7	58.3	14.5	41.2	-7.0	79.9	-20.6	28.7	42.9	-2200
June, 1925.....	26.6	65.9	62.9	57.0	3.8	39.2	-21.2	74.1	45.5	63.0	44.5	-1068
July, 1925.....	22.5	84.1	46.0	69.0	11.1	50.8	-50.8	81.0	-24.8	38.7	16.7	-1600
Aug., 1925.....	33.8	84.8	60.5	91.4	16.7	59.1	-43.3	80.6	53.2	67.0	12.5	-1120
Sept., 1925.....	0.0	75.0	43.8	77.1	7.4	44.5	-9.1	69.9	0.0	40.3	25.0	-1300
Oct., 1925.....	36.3	82.3	66.7	89.3	20.8	57.0	-8.7	64.4	38.5	55.0	12.5	-565
Nov., 1925.....	45.8	82.4	54.5	65.9	28.3	56.6	25.4	84.6	20.0	48.8	0.0	-550
Averages*.....	29.4	71.5	57.8	68.2	14.9	56.1	-8.4	48.8	11.0	51.8	11.1	-700

* Average percentages were calculated from the averages of the analyses and are not the averages of the percentages in this table.

The data are practically self-explanatory and show clearly the work performed by the plant. The somewhat poorer results obtained from the filter during September and October are due to the experiment conducted. All of the sewage was caused to pass through the east filter during that period, with the result that the heavy load caused a marked deterioration in the quality of the effluent. About the middle of October the west filter was again put into operation, but some time was required to bring it to maturity once more. The other features of operation need no further mention at this point.

Series B Samples.—Series B represents grab samples collected from the influent to the filter, from the two, four, six and eight-foot sampling pipes, and from the effluent of the ten-foot filter. These samples were collected every Thursday morning at ten o'clock. This time was selected in order to secure data on the purification of a weak sewage. Because of the four-hour detention period in the Imhoff tanks, the weak sewage entering the tanks at about six a. m. went to the filters about ten a. m. The analytical data are given in Table XX in the Appendix.

Series C Samples.—Series C represents grab samples collected from the same six sources as series B samples. These samples were collected every Thursday at four p. m. in order to secure data on the purification of the strongest sewage received at this plant. The four o'clock samples at the filter represented sewage entering the plant about noon. At this time the volume and strength were greatest. The analytical data are given in Table XXI in the Appendix.

Series D Samples.—Series D represents grab samples collected from the six sources mentioned before. These samples were collected every six days at two p. m. in order to secure data on a fairly heavy sewage on different days of the week. The differences in the sewage going to the filters at different times of the day were not so great, however, as the differences in the raw sewage, due to the buffer-like action of the Imhoff tanks. Analytical data are given in Table XXII in the Appendix.

The averages of all the data are given in Table X, and the percentage purification at the various depths of the bed, as judged by six different tests, is shown by the graphs in Figs. 9, 10 and 11. Results of series B, C, and D are represented by the different symbols, and each of the curves drawn through these points is the average of the analyses from twenty-two sets of six samples each in series B, twenty-two sets in series C, and twenty-seven sets in series D, making a total of seventy-one samples from each of the six sources.

TABLE X.—ANALYTICAL DATA FROM DIFFERENT LEVELS IN SPRINKLING FILTER.

Averages.

Series	Month 1925	Flow MGD		Temperature °C				cc. flow per spray				Turbidity				Suspended Solids				Oxygen Consumed				Ammonia				Nitrogen							
		Av.	Max.	Av.	Min.	Max.	Eff.	2 ft.	4 ft.	6 ft.	8 ft.	Infl.	2 ft.	4 ft.	6 ft.	8 ft.	Infl.	2 ft.	4 ft.	6 ft.	8 ft.	Infl.	2 ft.	4 ft.	6 ft.	8 ft.	Infl.	2 ft.	4 ft.	6 ft.	8 ft.	Infl.	2 ft.	4 ft.	6 ft.
B	March	2.7	3.2	0.8	13.6	11.0	11.0	1350	795	630	1230	110	72	70	50	35	52	53	23	37	16	54	40	27	26	21	18	20	15	30.0	22.0	4.5	4.3	4.0	4.2
	April	3.1	4.0	6.7	18.9	12.4	13.7	384	262	858	932	129	70	70	50	35	30	66	214	464	714	228	416	62	63	66	48	48	20.6	11.8	6.5	5.0	3.5	3.2	
	May	2.3	2.7	9.3	26.0	15.1	16.4	1170	557	880	1895	175	42	75	35	32	75	64	128	237	209	177	207	53	51	58	48	58	21.5	13.4	5.2	3.0	2.5	1.8	
	June	2.0	2.5	15.6	32.4	18.4	20.7	1540	746	814	1630	152	61	49	46	35	44	78	79	130	83	70	90	57	49	47	52	50	31	25.0	13.1	5.1	2.6	2.6	3.2
	July	2.1	2.5	18.6	31.9	20.0	22.3	1112	496	932	1598	224	53	64	50	47	38	118	85	108	96	85	102	47	40	38	34	31	32	32.4	12.6	7.8	2.6	2.4	2.9
Average		2.4	2.9	—	—	16.3	17.7	1212	777	813	1488	163	62	64	46	38	93	81	93	166	188	104	144	48	44	43	37	40	34	25.5	13.6	6.0	3.2	2.9	2.9
C	March	2.7	2.8	0.8	13.6	11.2	12.5	1025	690	490	850	155	92	110	95	50	52	80	35	47	17	98	50	47	32	46	33	33	31	33.0	27.0	28.0	9.0	4.2	5.2
	April	3.1	3.4	6.7	18.9	14.5	13.8	378	192	784	1048	188	100	120	60	50	60	129	222	500	343	200	327	76	70	76	55	57	73	26.8	21.6	7.4	6.4	3.9	5.7
	May	2.3	2.9	9.3	26.0	17.2	15.7	1317	430	709	1708	207	81	49	37	26	34	98	113	156	179	104	173	80	58	54	61	51	53	22.2	12.7	5.3	4.0	3.1	3.2
	June	2.0	2.5	15.8	32.4	19.7	20.1	1565	740	807	1654	231	51	51	46	40	60	73	67	69	70	65	83	74	56	40	53	54	55	25.4	12.9	4.2	2.3	2.4	3.0
	July	2.1	2.4	18.6	31.9	21.1	22.2	1152	775	668	1416	248	60	70	50	47	48	120	81	84	76	73	89	61	45	39	34	33	36	26.1	10.3	4.8	2.8	2.0	2.4
Average		2.4	2.8	—	—	17.5	17.6	1031	563	625	1211	206	74	73	53	41	46	100	89	146	117	91	121	66	50	48	45	43	46	26.0	15.7	9.6	4.6	3.3	3.8
D	Nov. 1924	—	—	—	—	18.7	8.5	970	1980	1275	1310	245	235	250	235	145	235	122	—	—	—	—	150	—	—	—	—	—	—	19.5	19.5	19.5	18.2	18.2	18.2
	Dec. 1924	—	—	—	—	13.9	7.0	820	810	920	700	310	250	230	210	210	136	—	—	—	—	—	—	—	—	—	—	—	—	19.0	19.0	21.0	19.0	19.0	19.0
	March	3.0	3.4	3.4	9.2	11.7	4.5	1463	577	482	1285	166	113	107	82	82	60	103	50	45	41	49	45	53	41	34	33	28	26	37.2	31.3	15.6	9.6	12.0	11.6
	April	2.8	3.3	4.9	20.4	14.5	13.1	392	162	804	1048	142	147	84	96	86	124	113	223	457	376	200	245	83	83	70	56	54	54	22.4	14.6	7.6	6.6	7.5	5.4
	May	2.3	2.9	8.2	26.0	16.7	15.7	1247	577	677	1835	234	97	61	36	34	37	153	249	235	239	107	215	88	77	67	67	56	69	23.4	15.4	8.0	4.8	3.6	4.6
Average		2.2	2.4	14.3	14.9	20.7	22.5	1620	832	910	1868	254	85	75	63	58	57	131	113	103	104	86	111	64	47	41	42	41	38	29.6	19.6	6.5	3.9	4.0	3.7
E	March	2.4	3.2	16.5	28.1	21.2	21.4	1452	452	644	1436	222	79	48	43	36	33	105	29	22	21	14	11	58	34	27	25	22	23	23.0	11.0	4.3	1.5	1.9	2.8
	April	2.4	2.9	—	—	16.1	14.8	1196	622	803	1389	220	106	77	63	58	61	121	147	161	147	90	130	73	60	50	46	42	44	27.0	18.3	7.4	4.9	5.3	5.2
	BCD Av.	2.4	2.8	11.0	25.5	17.1	17.5	1174	655	714	1408	147	81	71	54	45	50	99	148	185	177	112	159	63	51	47	42	41	26.2	15.8	7.8	4.2	3.8	4.0	
	Sept.	2.6	3.0	14.3	28.9	19.9	19.7	3426	2511	2424	3360	153	69	44	33	35	33	83	272	98	57	121	101	54	37	33	30	28	27	24.4	14.2	9.2	6.6	6.0	6.4
	Oct.	3.3	4.0	0.8	9.5	14.1	14.1	1344	624	436	1580	194	66	40	40	36	40	86	106	54	32	116	79	51	31	26	22	25	26	20.9	12.6	3.2	1.5	1.7	3.1

TABLE X.—(Continued).

Series	Month 1925	Albuminoid Nitrogen					Total Organic Nitrogen					Nitrate Nitrogen					Nitrite Nitrogen					pH					Percent Stability											
		ml	2 fl.	4 fl.	6 fl.	8 fl.	ml	2 fl.	4 fl.	6 fl.	8 fl.	ml	2 fl.	4 fl.	6 fl.	8 fl.	ml	2 fl.	4 fl.	6 fl.	8 fl.	ml	2 fl.	4 fl.	6 fl.	8 fl.	ml	2 fl.	4 fl.	6 fl.	8 fl.							
B	March	40	14	08	06	13	12	15.0	15.0	7.0	5.3	3.8	7.8	27	23	28	8.0	11.0	9.6	5.0	.52	.67	.57	.37	4.5	7.5	7.8	7.7	7.7	7.5	16	44	50	79	90	90		
	April	48	41	42	54	40	44	15.9	10.6	10.8	12.3	8.1	7.6	1.9	5.1	10.4	9.2	14.3	15.2	34	7.6	.88	.69	7.7	6.5	7.5	7.9	7.9	7.7	11	57	90	74	90	90			
	May	78	34	45	34	40	38	17.0	10.1	8.2	5.7	7.7	7.0	0.9	6.0	12.2	13.0	15.0	15.3	48	1.32	2.47	1.50	1.56	1.14	7.4	7.9	7.9	7.9	7.8	11	55	90	90	90	90		
	June	3.0	3.7	3.1	2.8	2.3	3.1	16.4	22.0	10.8	9.2	10.6	7.8	0.5	5.9	14.4	16.8	14.0	16.2	07	2.34	2.35	1.47	1.91	1.44	7.3	8.2	8.2	8.2	8.2	11	84	87	90	90	90		
	July	42	34	42	31	31	34	10.4	15.8	9.5	7.7	8.7	10.7	0.7	6.9	10.5	14.4	13.2	14.3	00	3.33	2.49	1.71	1.88	1.70	7.1	7.8	7.6	7.6	7.8	7.8	11	74	88	90	90	90	
	August	3.2	1.9	1.8	1.1	1.0	1.4	4.8	9.4	0.1	4.4	1.9	2.0	0.4	5.0	7.0	10.8	13.2	9.6	0.5	5.63	3.68	1.25	2.00	1.43	7.1	7.8	7.8	7.8	7.8	11	77	90	90	90	90		
	Average	4.6	3.1	3.1	2.7	2.6	2.9	13.3	13.8	7.7	7.4	6.7	7.1	1.2	5.2	9.6	12.1	13.5	13.4	24	2.31	2.04	1.20	1.40	1.13	7.3	7.9	7.9	7.9	7.9	11	67	90	90	90	90		
	C	March	60	40	40	1.2	1.2	1.0	5.0	17.0	6.0	5.0	3.8	4.7	1.6	1.0	1.9	8.0	12.0	13.2	4.5	4.5	4.0	7.2	7.7	9.0	7.6	8.0	7.9	7.9	7.7	11	20	74	90	90	90	
April		5.2	6.0	7.1	5.0	3.4	6.4	11.1	11.8	18.5	10.6	4.8	8.8	1.1	3.9	14.3	13.7	14.1	14.6	2.4	7.1	.88	.67	.91	7.5	7.6	7.9	7.7	7.9	7.8	7.6	11	29	83	74	90	90	
May		48	38	34	3.5	3.2	3.6	13.3	9.4	5.8	5.6	5.8	5.8	0.3	4.8	13.9	15.4	14.8	17.1	00	1.10	2.27	1.72	1.52	1.10	7.3	7.8	7.8	7.8	7.8	7.7	11	14	87	90	90	90	
June		48	3.3	3.0	2.9	2.7	3.1	22.4	17.6	7.4	10.0	9.2	13.4	1.2	5.5	10.4	12.5	16.1	12.8	00	2.12	2.81	1.47	1.46	1.59	7.4	8.2	8.2	8.2	8.2	11	21	30	90	90	90		
July		3.4	4.0	3.9	3.0	3.4	3.6	13.1	14.8	10.7	12.6	11.2	8.5	0.5	7.1	13.0	12.8	13.3	14.7	00	3.31	2.53	1.46	1.78	1.74	7.1	7.8	7.8	7.8	7.8	11	48	90	90	90	90		
August		2.9	1.7	2.2	1.5	0.8	1.2	7.6	7.6	2.6	1.9	1.2	4.8	0.8	4.6	7.8	10.6	8.8	8.8	00	4.31	2.18	.87	.81	1.87	7.1	7.8	7.8	7.8	7.8	11	40	70	90	90	90		
Average		4.6	3.8	3.9	2.8	2.4	3.1	12.1	13.0	8.5	7.6	6.0	7.7	0.9	4.5	10.2	12.1	13.2	13.5	12	2.00	1.85	1.15	1.21	1.32	7.3	7.9	7.9	7.9	7.9	11	28	63	90	90	90		
D		Nov. 1924	—	—	—	—	—	17.0	—	—	—	—	—	—	—	13.2	0.2	0.2	0.2	0.1	0.1	0.0	.00	.01	.01	.01	.01	—	—	—	—	—	11	11	11	11	11	11
	Dec. 1924	—	—	—	—	—	18.0	—	—	—	—	—	—	—	10.0	0.5	0.5	0.4	0.3	0.1	0.1	0.3	.02	.02	.02	.02	.01	—	—	—	—	—	11	11	11	11	11	11
	March	5.1	4.9	4.1	3.4	4.4	3.1	14.2	17.7	3.0	8.0	3.0	4.0	2.6	2.1	4.8	17.3	15.4	12.0	6.0	.53	.54	.67	.78	.65	7.6	7.8	7.8	7.8	7.8	7.7	11	14	11	57	74	76	
	April	5.5	5.4	4.4	7.4	5.0	4.5	15.6	12.2	12.1	6.8	5.4	8.8	0.4	4.2	12.2	14.8	16.4	17.0	3.7	.86	.87	.93	1.02	.84	7.5	7.8	7.9	7.8	7.8	7.6	11	31	76	87	86	90	
	May	6.0	6.0	4.0	4.2	3.6	4.1	14.4	14.8	10.3	7.5	8.3	8.5	0.8	4.2	13.4	15.0	15.0	16.7	00	1.31	2.07	1.64	1.82	1.50	7.3	7.8	7.4	7.9	7.7	11	13	75	90	90	90		
	June	6.7	7.8	4.6	3.5	3.6	3.6	22.8	22.1	8.8	10.1	10.6	7.4	0.6	4.9	12.4	16.8	14.6	16.6	00	2.90	3.30	2.71	2.49	2.60	7.2	7.8	7.4	7.9	7.8	11	11	87	90	90	90		
	July	4.8	4.1	3.4	4.1	3.4	4.2	17.6	13.2	13.6	10.3	9.6	8.5	0.4	5.3	13.4	16.4	15.5	16.5	00	3.70	3.01	2.27	2.44	2.41	7.1	7.8	7.8	7.8	7.7	11	34	88	90	90	90		
	August	4.2	3.3	1.8	1.6	1.4	1.9	11.2	6.8	2.8	2.4	3.6	4.4	0.5	5.7	9.8	12.6	10.5	12.6	00	3.45	2.47	.54	.44	1.61	7.1	7.8	7.8	7.8	7.8	11	42	90	90	90	90		
Average	5.4	5.3	3.9	4.0	3.8	3.6	16.4	15.3	8.4	7.5	6.8	6.4	1.0	4.4	11.0	15.5	14.7	15.2	12	1.50	1.47	1.07	1.26	1.21	7.3	7.8	7.8	7.8	7.8	11	24	71	90	90	90			
BCP Av.	4.8	4.1	3.6	3.2	2.9	3.2	14.1	14.0	8.2	7.5	6.5	7.2	1.0	4.7	10.3	13.2	13.8	14.0	17	2.14	1.46	1.26	1.45	1.35	7.3	7.8	7.8	7.8	7.8	11	39	72	85	84	84			
E	Sept.	3.6	2.1	1.6	1.3	1.5	1.5	7.8	4.9	3.4	3.5	4.4	4.5	0.4	3.8	6.1	7.4	8.2	6.8	0.6	3.68	1.43	1.31	1.10	1.36	7.0	7.7	7.8	7.8	7.8	11	44	81	84	84	84		
	6 Oct.	3.4	2.0	1.9	1.5	1.6	1.7	7.8	4.4	4.3	3.5	3.3	4.5	0.3	3.9	4.7	10.4	9.6	10.4	2.0	1.08	.43	.42	.37	.55	7.3	7.8	7.8	7.8	7.8	11	57	90	90	90	90		

DEPTH OF SEWAGE FILTERS

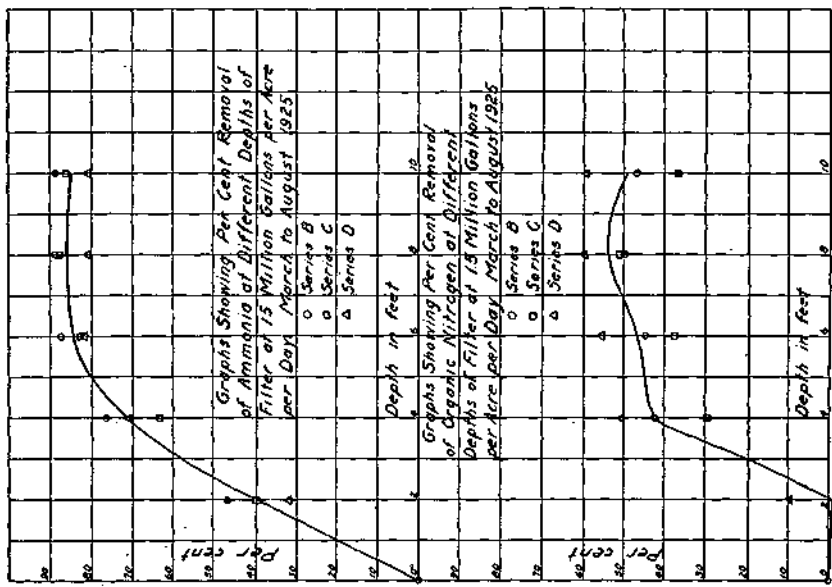

FIG. 10.

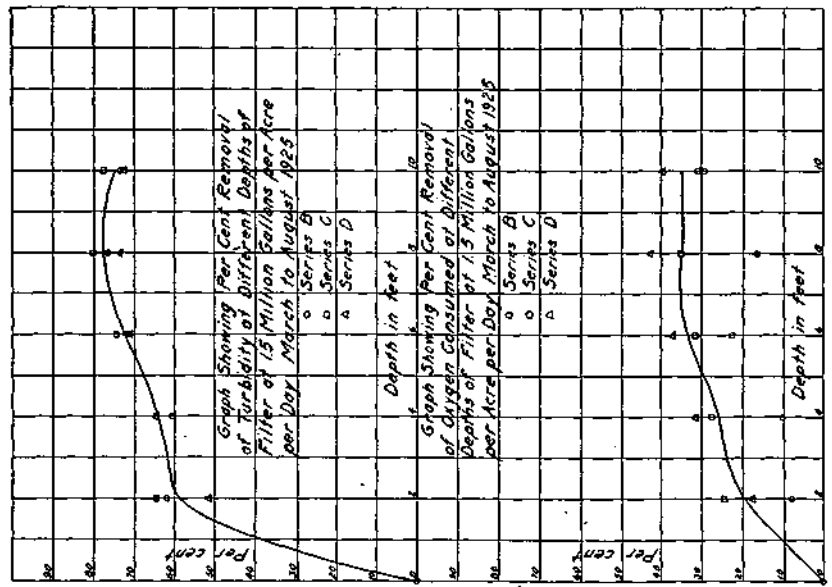

FIG. 9.

An inspection of these curves shows that at a depth of six feet practically all of the purification has been effected. In some cases the effluent values show less purification than that at the six- or eight-foot levels. This is probably due to the sampling error or to a phenomenon which can be understood by a reference to Buswell's spiral (see above, page 15), for it is possible that the progress

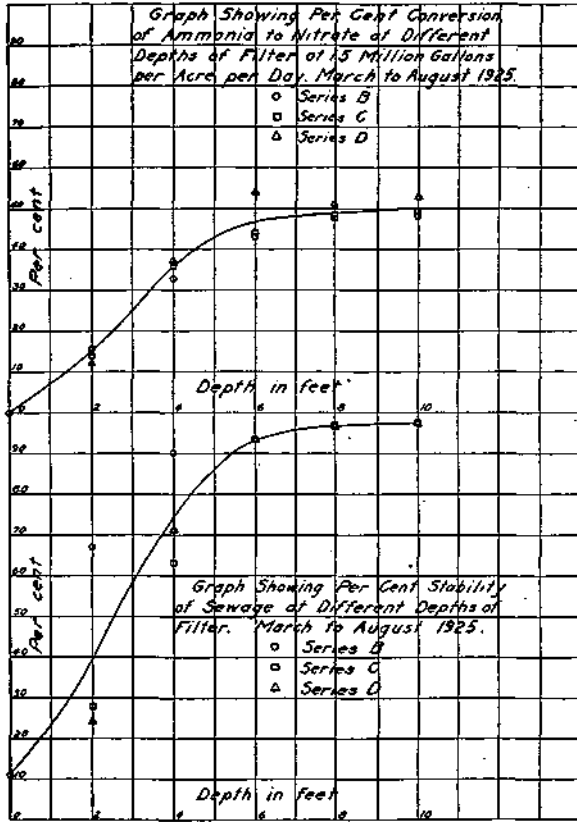

FIG. 11.

around the spiral may be stopped at a point where the living material is rapidly dying and sloughing off the stones. In this unorganized and more or less colloidal state it would increase the putrescible organic matter in the effluent. In a private communication Max Levine stated that with 'one-half per cent skim milk there was a

greater reduction of oxygen consumed, organic nitrogen and total solids in three feet of filtration than in six feet. With higher concentration, say about one per cent, the maximum reduction of these constituents was sometimes obtained at the four- or five-foot depth. With still higher concentrations he was unable to obtain stable effluents or nitrification, and the reduction was gradual.

As mentioned before, the samples from the pipes represent the sewage from one complete spray, while the effluent sample was dipped from the gutter. Although every attempt was made to take the sample when the sewage reached the same height in the gutter each time, the difficulty of securing an average or representative sample is evident. For this reason, any decrease in purification as shown by the effluent of the ten-foot filter must be interpreted with care. Fig. 12 shows the fluctuation in ammonia and nitrate nitrogen for one complete cycle of nine minutes when the filters were operating at their normal rate.

The dosing cycle, timed at ten a. m., while the filter was operating at the normal rate of one and a half million gallons per acre per day, consisted of two and a half minutes spraying and six and a half minutes of rest. This sequence was not maintained regularly, because the pump was shut off by a float when the level of sewage in

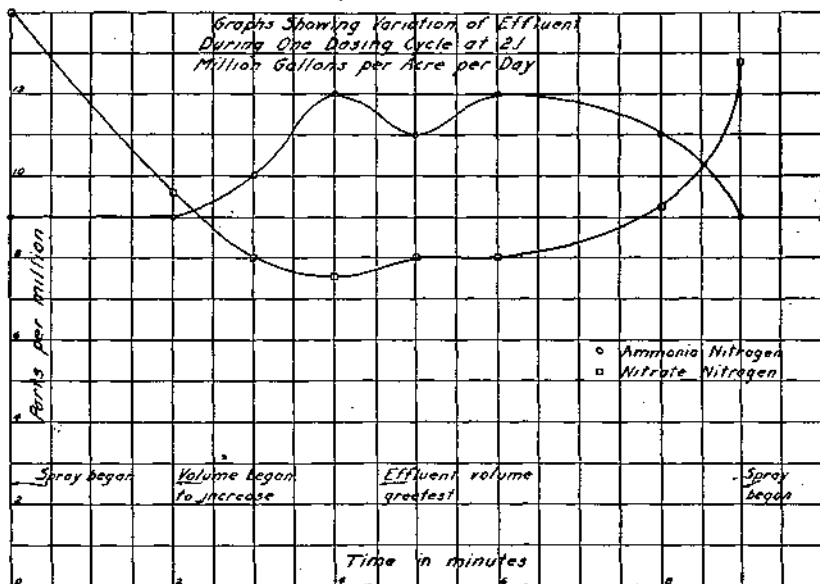

FIG. 12.

the well receiving the Imhoff tank effluent reached a certain minimum. Pumping was intermittent because the pump capacity was greater than the rate of flow of sewage into this well.

Series E Samples.—When the experiments had proceeded for six months, Mr. S. A. Greeley suggested that if the plant were operating at the rated capacity for 1945, the lower four feet of the filter would assume a proportionate share of the work of purification. In other words, the volume of sewage would then be so great that the upper portion could not treat it; hence, it would be left for the lower portions of the filter to accomplish. Therefore, in order to study the behavior of the filter under the theoretical 1945 rate of dosage, stop-planks were put in the inlet to the west dosing tank on August 27, to cause the entire sewage flow to enter the east dosing tank and spray on the east filter at a rate twice as great as previously.

Under this arrangement the sewage was pumped into the dosing tank while it was still discharging. About the middle of September owing to the opening of the University, the sewage flow increased almost fifty per cent, but the sewage did not become more concentrated. However, when handling this increased flow, the three-million-gallon pump did not deliver the sewage into the dosing tank rapidly enough to allow the level to drop gradually throughout the whole time of pumping. This caused most of the sewage to be sprayed from the nozzles in a circle having a radius of about eight inches, and resulted in extremely inefficient distribution. To remedy this condition, the five-million-gallon pump was used. The sewage then entered the dosing tank at a very slightly lower rate than it left, causing the level to fall at such a rate as to reach a minimum about the same time the pumps were stopped by the automatic shut-off in the pump house. This condition caused the distribution to be quite satisfactory. The dosing cycles timed at 10 a. m., while operating at this rate of about three and a quarter million gallons per ° acre per day, are given in Table XI. Intermittent pumping, due to variations in the sewage flow, caused this to change at different times of the day.

The operation of the filter at this high rate was continued for six weeks. Samples taken during this experiment were called series E. The analytical data are given in Table XXIII in the appendix, and the results graphically represented in Fig. 13. The general shape of the curves is the same as the shape of those obtained while operating at the lower rate. The apparent decrease in purification

shown by the effluent may be accounted for in part by difficulty of securing a representative grab sample of such a large volume of sewage or by other factors already discussed. The dosing cycle was about twice as long as in series B, C and D, and the variations in the effluent during one spray were even more pronounced than before, as seen in Fig. 14.

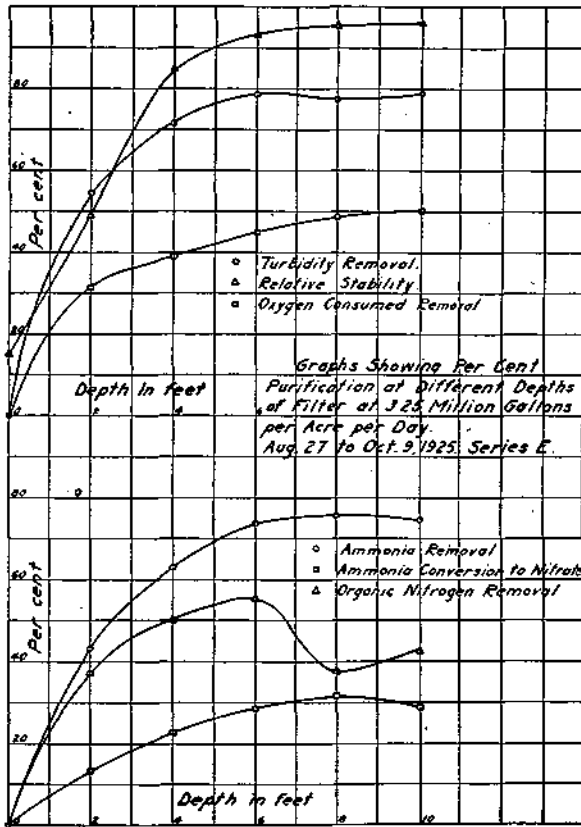

FIG. 13.

TABLE XI.—DOSING CYCLE USING EAST FILTER ONLY.

Sewage flow M. G. A. D.	Pump used	Time of spray	Time of rest
3.0.....	3 M. G. D.	8.6 min.	10.8 min.
4.2.....	5 M. G. D.	11.6 min.	7.1 min.

The turbidity removal and ammonia removal were only slightly less than before, but the nitrification was just about sixty per cent of its previous value. This shows that the bed was removing the colloidal matter, ammonia, etc., but was unable to oxidize and mineralize this nitrogenous matter, which suggests a probable deficiency in the oxygen supply. As pointed out in the discussion of intermittency, most of the oxygen used in the oxidation reactions in the filter probably comes from the air drawn into the bed to replace the sewage draining from the bed during intermittent dosing. The

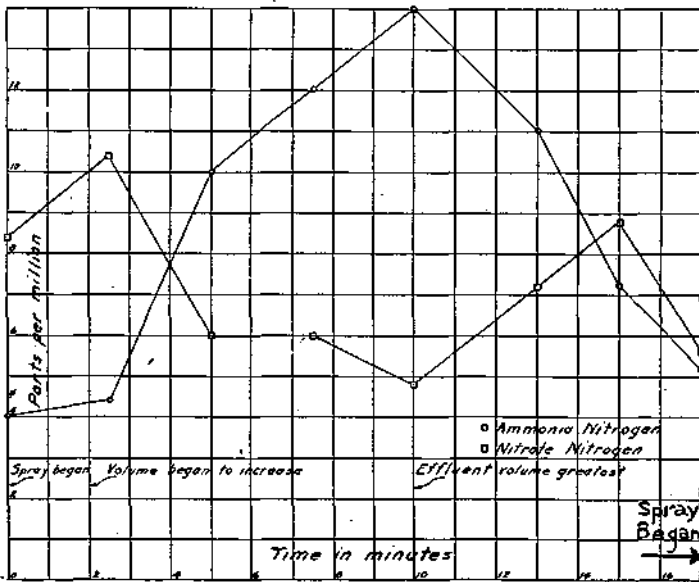

FIG. 14.

Graphs Showing Variation of Effluent During One Dosing Cycle at 3.25 Million Gallons per Acre per Day.

TABLE XII.—COMPARISON OF DOSING CYCLES.

Sewage flow M. G. A. D.	Time of spray	Time of resting	Ratio rest; spray
1.5.....	2.5 min.	6.5 min.	2.6
3.0.....	8.6 min.	10.8 min.	1.26
4.2.....	11.6 min.	7.1 min.	.65

relation between time of spraying and time of resting at the two rates of treatment supports this view and furnishes a reason why nitrification fell off during the six weeks experiment.

Prom Table XII it is seen that, at the lower rate of treatment, the bed rests four times as long as it does at the high rate. During this resting stage, the oxidation and nitrification take place most rapidly because oxygen has free access to the bacterial film. The extent to which this nitrification takes place in a resting bed is illustrated by Table XIII. These samples represent the first effluents from the bed when operation was resumed after varying periods of rest.

TABLE XIII.—NITRIFICATION DURING REST PERIODS.

Sample number	Time of rest	Nitrate nitrogen p.p.m.
53371.....	5 days	80.0
53396.....	2 days	44.0
53973.....	12 hrs.	51.2
54997.....	12 hrs.	51.2

Since the time of rest was four times as great, and the resting time is the time of most active nitrification, presumably because of the plentiful supply of oxygen, it can be understood why nitrification proceeded more rapidly in the filter when it was receiving less sewage.

One series of biochemical oxygen demand tests was made on October 7. The rate of treatment at the time the samples were taken was four and a half million gallons per acre per day, which caused the sprays to operate almost continuously. While only one set of results is available, it shows the same trend as the curves representing other tests. Table XIV shows the biochemical oxygen demands at five days and at twenty days.

Fig. 15 shows the relation existing between the biochemical oxygen demands for five days and twenty days and the per cent stabilities of the samples. The drop in the curves at the eight-foot level is due to the fact that the curves represent only one set of grab samples. The average of many samples would undoubtedly smooth out this irregularity.

TABLE XIV.—BIOCHEMICAL OXYGEN DEMANDS AT DIFFERENT DEPTHS OF FILTER.

Sample number	Filter depth feet	5-day demand p.p.m.	Per cent removal	20-day demand p.p.m.	Per cent removal
55311.....	0	85	0.0	90	0.0
55312.....	2	39	54.1	57	36.6
55313.....	4	19	77.6	36	60.0
55314.....	6	10	88.3	20	77.8
55315.....	8	18	78.8	36	60.0
55316.....	10	8	90.6	17	81.1

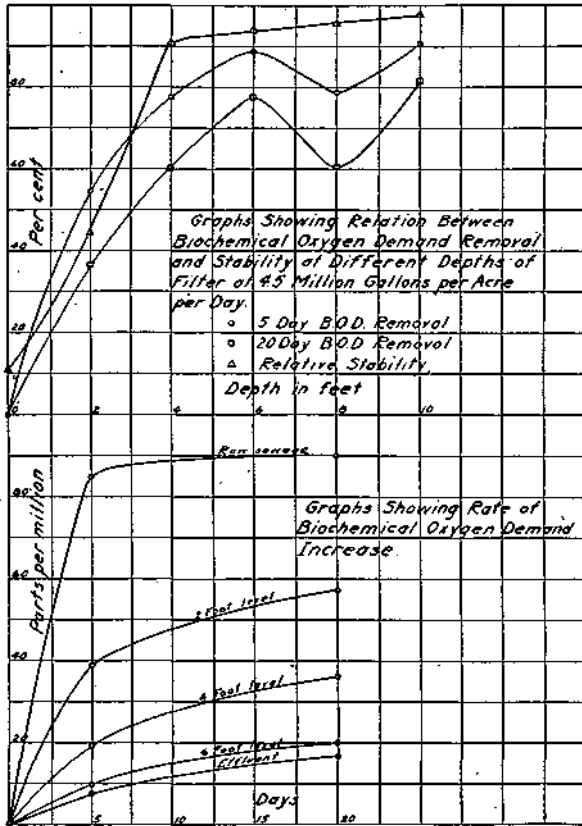

FIG. 15.

The results of this series of tests furnish another striking example that biological processes cannot be regarded as linear functions of time. Instead, as the graphs in the lower half of Fig. 15 show, they proceed rapidly at first, when food, oxygen, etc., are most concentrated; then they slow down quite markedly as these essentials are used up. These curves, which are quite similar to those representing the rate of purification in a filter, furnish collateral evidence indicating that the course of such reactions does not follow a straight line.

At the end of six weeks of treatment at the rate of approximately three and a quarter million gallons per acre per day, the bed began to show the first signs of ponding. A whitish mold growth appeared in circles around each sprinkler nozzle. Dr. Hatfield, Superintendent of the Decatur treatment plant, said the appearance of this growth on his filters was always followed by ponding. Because of this development and the apparent inability of the filter to oxidize its stored nitrogenous matter, it is doubtful if the filter would continue to function properly if dosed at this high rate for long periods of time.

Series G Samples.—On October 13, the west filter was again put into operation. The cycle for each bed was two and a half minutes spraying and six and a half minutes rest; the rate of dosage for the period during which samples were taken was two and one-tenth million gallons per acre per day. Series G samples were collected from the same six sources as in the previous experiments from October 14 to November 11, 1925. These results are given in Table XXIII in the Appendix, and the results are graphically represented in Fig. 16. The general shape of the curves is the same as in the previous series. The number of samples was not sufficiently great to smooth out some of the irregularities due to the sampling errors, but the trend of the curves is unmistakable. Disregarding minor fluctuations, the proportion of the purification effected below a depth of six feet is very small in comparison with that effected by the first six feet.

For convenience in comparing the results of operation at the different rates of flow in August, September and October, data selected from Table X are presented in Table XV and are recalculated to show percentage removal in Table XVI. (Compare Figures 9, 10, 11, 13 and 16.)

TABLE XV.—ANALYTICAL DATA FROM DIFFERENT LEVELS IN SPRINKLING FILTER.

Determinations.	Infl.	2 ft.	4 ft.	6 ft.	8 ft.	Effl.
-----------------	-------	-------	-------	-------	-------	-------

August Averages (Series D)

Flow 1.5 M. G. A. D.

Flow per spray (cc.)	1452	952	644	1436		
Turbidity (ppm.)	222	79	48	43	36	33
Suspended solids (ppm.)	105	29	22	21	14	11
Oxygen consumed (ppm.)	58	34	27	25	22	23
Ammonia nitrogen (ppm.)	23	11	4.3	1.5	1.9	2.6
Albuminoid nitrogen (ppm.)	4.2	3.3	1.8	1.6	1.4	1.9
Total organic nitrogen (ppm.)	11.2	6.8	2.8	2.4	3.6	4.4
Nitrate nitrogen (ppm.)	0.5	5.7	9.8	12.6	10.5	12.6
Nitrite nitrogen (ppm.)	0.0	3.45	1.97	.39	.99	1.61
pH	7.1	7.8	7.8	7.8	7.8	7.8
Per cent stability	11.	42.	90+	90+	90+	90+

September Averages (Series E)

Flow 3.25 M. G. A. D.

Flow per spray (cc.)	3628	2511	2924	3360		
Turbidity (ppm.)	153	69	44	33	35	33
Suspended solids (ppm.)	83	272	98	57	121	101
Oxygen consumed (ppm.)	54	37	33	30	28	27
Ammonia nitrogen (ppm.)	24.9	14.2	9.2	6.6	6.0	6.4
Albuminoid nitrogen (ppm.)	3.6	2.1	1.6	1.3	1.5	1.5
Total organic nitrogen (ppm.)	7.8	4.9	3.9	3.5	4.9	4.5
Nitrate nitrogen (ppm.)	0.4	3.8	6.1	7.4	8.2	6.8
Nitrite nitrogen (ppm.)	0.06	3.68	1.93	1.31	1.10	1.36
pH	7.0	7.7	7.8	7.8	7.8	7.8
Per cent stability	11	49	81	89	89	89

October Averages (Series G)

Flow 2.1 M. G. A. D.

Flow per spray (cc.)	1349	629	436	1580		
Turbidity (ppm.)	199	66	40	40	36	40
Suspended solids (ppm.)	86	106	54	32	116	79
Oxygen consumed (ppm.)	51	31	26	22	25	26
Ammonia nitrogen (ppm.)	20.9	12.6	3.2	1.5	1.7	3.1
Albuminoid nitrogen (ppm.)	3.4	2.0	1.9	1.5	1.6	1.7
Total organic nitrogen (ppm.)	9.8	4.4	4.3	3.5	3.3	4.5
Nitrate nitrogen (ppm.)	0.3	3.9	9.7	10.9	9.6	10.9
Nitrite nitrogen (ppm.)	0.20	1.08	0.43	0.42	0.37	0.55
pH	7.3	7.8	7.8	7.8	7.8	7.8
Per cent stability	11.	57	90+	90+	90+	90+

Maturing of filter after rest.—Samples were also taken from the effluent of the west bed when it was again put into operation after the shut-down of six weeks, in order to trace the maturing of the bed under these conditions. Samples were taken from the first few sprays and at various intervals thereafter for four weeks. From the data presented in Table XVII it can be seen that the first five sprays washed out much of the bacterial growth which had dried during the period of disuse. The purification dropped off as a

TABLE XVI.—PER CENT OF ORGANIC MATTER REMOVED BY DIFFERENT DEPTHS OF FILTER AT DIFFERENT RATES OF DOSING.

Rate M. G. A. D.	Turbidity	Oxygen consumed	NH ₃	Org. N.	Per cent NH ₃ to NO ₃	Per cent stability
2 ft.						
1.5.....	65	41	52	39	25	42
2.1.....	67	39.0	40	55	18	57
3.25.....	55	32	43	37	13	49
4 ft.						
1.5.....	79	53	82	75	43	90+
2.1.....	79	50	84	56	45	90+
3.25.....	72	39	63	50	22	81
6 ft.						
1.5.....	81	57	94	79	55	90+
2.1.....	79	57	92	63	50	90+
3.25.....	79	44	74	55	29	89
8 ft.						
1.5.....	84	62	92	68	46	90+
2.1.....	82	52	91	66	45	90+
3.25.....	77	48	75	38	31	89
10 ft.						
1.5.....	85	60	89	61	55	90+
2.1.....	79	50	85	53	50	90+
3.25.....	79	50	74	42	29	89

natural result, and six days were required to bring the filter to the stage where a stable effluent was produced. The graphs shown in Fig. 17 show the course of this maturing as indicated by ammonia and nitrate nitrogen content.

Effect of Sample Volumes.—As mentioned before, Rudolfs attaches much significance to the volume of sample obtained from the sampling pipes. Our objections to his method of arbitrarily correcting analytical data on the basis of the volume of sample have been expressed in a previous section (page 34). We believe that the average of many samples gives a true picture of conditions at any particular level of the bed. For instance, one day a large volume may be obtained from one pipe; the next day a low volume; and still another day a medium volume. Unless there is some permanent

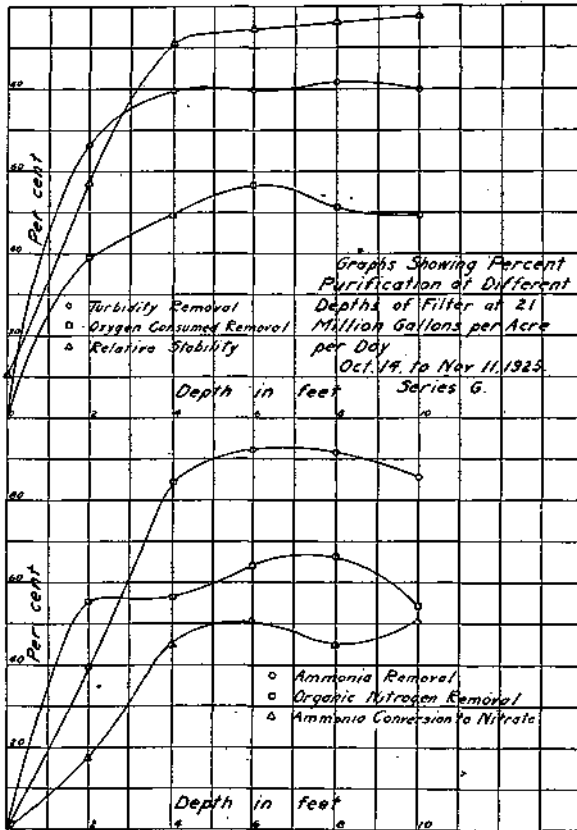

FIG. 16.

TABLE XVII.—ANALYSES OF SETTLED EFFLUENT OF EAST FILTER AFTER SHUT-DOWN OF SIX WEEKS.

Results Expressed in Parts Per Million.

Sample No.	Date, 1925	Turb.	Gooch solids ¹	Ox. cons.	Ammonia nitrogen	Alb. nitrogen	Org. nitrogen	Nitrate nitrogen	Nitrite nitrogen	Stability per cent
55375*	Oct. 13.....	90	752	48	5.2	2.0	6.4	7.0	.25	90+
55376*	Oct. 13.....	60	500	57	10.0	1.8	2.0	4.0	.23	90+
55377*	Oct. 13.....	60	184	40	10.4	1.8	2.8	4.4	.21	90+
55378*	Oct. 13.....	108	44	10.4	1.8	6.4	2.8	.16	75
55379*	Oct. 13.....	60	104	48	12.8	1.8	4.4	2.8	.09	60
55380*	Oct. 13.....	60	24	50	15.2	2.8	8.0	2.8	.09	30
55403	Oct. 14.....	45	21	37	10.0	2.8	7.2	3.2	.90	60
55433	Oct. 15.....	55	31	12.0	2.0	4.0	1.50
55452	Oct. 19.....	45	21	34	10.0	1.8	6.0	5.6	1.00	90+
55464	Oct. 20.....	40	19	45	11.0	1.8	2.2	4.0	2.00	90+
55499	Oct. 22.....	30	37	9.0	1.7	16.2	9.2	3.50	90+
55525	Oct. 27.....	40	9	26	6.0	1.1	3.6	8.8	4.00	90+
55548	Oct. 30.....	50	10	19	5.2	1.2	5.2	8.8	3.50	90+
55557	Nov. 2.....	45	30	27	4.4	2.1	4.0	14.0	2.80	90+
55613	Nov. 5.....	35	24	19	3.4	1.3	6.2	9.6	2.00	90+
55623	Nov. 6.....	30	15	19	3.0	1.0	7.2	1.80	90+
55634	Nov. 9.....	45	53	18	5.4	1.1	2.6	10.0	1.75	90+
55675	Nov. 11.....	30	20	0.6	1.1	8.8	1.35	90+

* Samples represent sprays 1, 2, 3, 4, 5, 11, respectively, after the filter was put into operation.

¹ Unsettled samples.

defect in the placing of the stones above the collectors, it is safe to assume that channelling and seepage will alternate and, over long periods, balance each other. Since many intermediate conditions between these two extremes can prevail at one level in different parts of the bed at the same time, then the average of conditions at one level may be obtained from the average of conditions at one sampling point over a long period. In other words, disregarding seasonal changes, the average of one hundred samples taken simultaneously from one complete spray at different parts of the six-foot level would be the same as the average of one hundred samples taken over several months from one complete spray at one sampling point at the six-foot level.

Another reason for not correcting our data for sample volumes lies in the fact that such correction would assume perfect distribu-

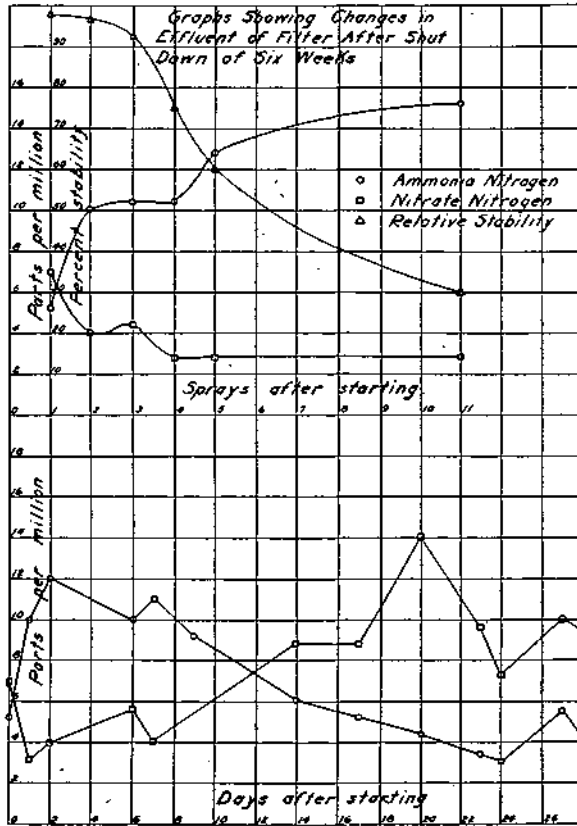

FIG. 17.

tion. The two-foot and the eight-foot sampling pipes are one foot three inches to the left and right, respectively, of the feeding nozzle; the four-foot and the six-foot pipes are two feet six inches to the right and left, respectively, of the same nozzle. The data for Series B, O, D and G show that the two-foot and eight-foot pipes consistently deliver a larger volume than the four-foot and six-foot pipes. This is obviously due to the position of the pipes and to the fact that perfect distribution was not secured: However, the high volume samples from the eight-foot pipe were of the same quality as the low volume samples from the six-foot level. Furthermore, during the experiment with the high rate of dosage, Series E, better distribution was secured and the samples from the different pipes were more nearly equal in volume; yet the analyses furnished curves of the same shape as before. Moreover, no consistent relationship has been found between the nitrates, for example, and the sample volume. High nitrate values were consistently obtained from the high volumes from the eight-foot pipe; and with an occasional high volume from the six-foot level, the nitrate value did not become abnormally low. Table XVIII shows the variations in volumes of samples which contained about the same amount of nitrates.

TABLE XVIII.—VARIATIONS IN VOLUMES OF SAMPLES CONTAINING SAME AMOUNTS OF NITRATES.

Six-foot depth at 1.5 M. G. A. D.		Eight-foot depth at 1.5 M. G. A. D.	
Nitrate N. p.p.m.	Sample c.c.	Nitrate N. p.p.m.	Sample c.c.
8.0	1780	10.0	1560
8.0	1000	10.4	1040
8.0	800	10.8	1500
8.0	460	13.2	1060
10.0	200	13.2	1740
10.0	900	13.6	1700
11.2	1440	13.6	1200
11.2	850	14.0	2280
11.2	580	14.0	1380
16.0	650	16.8	1560
16.0	1060	18.0	1720

DISCUSSION OF RESULTS

The data secured indicate that the quality of the final effluent from the ten-foot filter is no better than that from the six-foot level of the filter. The additional depth over six feet does not cause a more satisfactory effluent to be produced at materially higher rates than could be expected from a six-foot filter. Moreover, clogging and ponding become limiting factors in the employment of high rates of filtration.

The results point to the generalization that there is an optimum depth of filter beyond which it is neither necessary nor advisable to go in the installation of a plant. In the filter under investigation at Urbana the maximum amount of purification was brought about at a depth of six feet, and the additional depth did not appear to be advantageous, but it is undoubtedly true that this same depth might not be the optimum with different sewages and under other conditions. This should be borne in mind inasmuch as six feet is considered the optimum depth in this thesis.

These results are of interest not only from a chemical and biological standpoint, but also because of their economic significance. It has been pointed out in the preceding pages that the progress of the purification in the filter bed follows well established laws of chemistry and biology. The data are in close agreement with several previous experiments on this question and also with some analogous experiments on activated sludge.

Economic Aspects of Filter Depth.—Deep filters are built to accomplish one or more of several purposes. They may be expected to produce a better quality of effluent than a filter of less depth; or they may be expected to treat a larger volume of sewage per acre and so be able to take care of future increases in the sewage flow. Our work has led us to believe that any depth over six feet does not materially increase the quality of the effluent, and furthermore that there is a definite rate of treatment, beyond which the quality of effluent does not improve regardless of the depth of the filter.

In making preparations for the treatment of future increases in sewage flow by filters, a community has, in general, two courses open: (1) it may build a deep filter, say a ten-foot one, and rely on the great depth to handle the increase; (2) or it may build a shallow filter, say a six-foot-one, and add to it as needed. We will consider each of these courses separately.

The deeper filter will produce a better effluent, because the rate of treatment is not excessive, when the filter is first put into operation. The production of this high quality effluent, however, will be due to the upper six feet of the filter. Thus, while the filter is admittedly operating at a fairly low rate, the cost of pumping sewage four feet higher than necessary and of paying interest charges on the lower four feet of filter must be borne, even though no immediate advantage is derived from these lower four feet. Now, when the amount of sewage treated is doubled, we have found that the lower four feet still play a very small part in the purification. The upper six feet still do the bulk of the work but do not appear to do it as well, for the reasons which have been mentioned in a previous section (page 50). The charges for pumping against the ten-foot head and the interest on installation must still be paid, even though the filter is now turning out a poorer effluent than before.

On the other hand, when a community builds a six-foot filter and doses it at a normal rate, each foot of depth materially aids in the purification. It is true that the last foot does not do relatively as much as the first, but it does enough to warrant its presence in the filter. In this case the community saves the capital outlay for the added depth and, of course, the interest charges on that amount; furthermore, the pumping costs are decreased by the elimination of four feet of head. As the sewage flow increases, a new filter unit is installed and filtration proceeds at the normal and satisfactory rate. Although the total construction cost⁴⁷ will be somewhat greater in this case, because of the greater proportion of walls, underdrains and distribution systems to the volume of the filter in the shallower installations, the maximum work will be obtained from each foot of depth of the filter.

By reference to the curves it will be evident that the lower four feet of the ten-foot filter could be made more effective if they constituted the upper four feet of another filter. This leads to the proposition that if the volume of stones comprising the lower four feet were removed and rearranged to form a six-foot filter, we could purify to the same extent a much larger amount of sewage than before. To take a hypothetical case, let us assume that the filter is 2.0 acres in area and 10 feet deep, making a volume of 871,200 cubic feet. If this filter were rearranged to a six-foot depth we would have an area of 3.33 acres. According to our data, at the rate of 3.25 million gallons per acre per day the ten-foot filter would be overloaded; so we will assume that it can successfully handle 2.5

million gallons per acre per day, an amount which is not at all unreasonably large, because a six-foot filter can successfully treat 2.0 million gallons per acre per day. At these respective rates the two-acre ten-foot filter will have a capacity of 5 million gallons a day, and the six-foot filter, with an area which has been increased to 3.33 acres by the rearrangement suggested above, will have a capacity of 6.67 million gallons a day, or a 33 per cent. increase. Hence, by merely rearranging the volume of stones in accordance with the curves representing the progress of purification in the bed, the filter could successfully treat 33 per cent more sewage at a rate per acre 20 per cent lower than before. It should also be borne in mind that any advantage would be with the shallower filter at the lower rate. In the calculations, the rate assumed for the deeper filter is only 20 per cent greater than for the shallow filter while the depth is 66 per cent greater. If the rate were made proportional, it would be 3.25 million gallons per acre per day for the ten-foot filter, a rate which we found to be too high. If the same rates were assumed for both filters, then the advantage of the deep filter disappears; for why should a ten-foot filter be built when the purification produced is not appreciably better than that obtained with a six-foot filter?

Grading of Stones in a Filter.—In order to prevent clogging of the filter, the lower foot or so is generally constructed of stones larger than those used in the main body of the filter. Mechanically this seems to be necessary, but it is not in accord with principles employed in somewhat analogous chemical processes. For example, in the absorption of gases or the extraction of soluble substances from a given material the fresh absorbent or solvent always comes in contact with the most nearly spent gas or material, and the most concentrated solution comes in contact with the fresh gas or material. This counter current principle is not followed in the construction of the sprinkling filter, and as a result the strongest sewage trickles over the smallest stones and the largest surface area; the weak and partially treated sewage then trickles over the larger stones near the bottom and is thus exposed to less surface area per foot than before. It is a well-known fact that as the size of stones is increased, the purification effected is decreased, and at the bottom of a filter in which the size of stones is greater than in the main body of the filter we should expect this decrease in the rate of purification. It appears, then, that the factors of lowered concentration of the removable substances, and the smaller extent of surface exposed to the sewage both act to decrease the rate of purification at the bottom of the filter.

Theoretically, at least, a better arrangement would be one somewhat similar to a "roughing filter" or a "pre-filter." That is, a filter of larger stones, say four- to six-inch size, could be used to filter settled sewage at a rapid rate. The effluent would be settled and then filtered through a bed of one- to two-inch stones followed by sedimentation. In such a scheme the coarse filter would remove much of the colloidal matter, and this decrease in the organic loading would allow the fine filter to be operated at higher rates. The large voids in the coarse filter would prevent clogging and ponding, and at the same time allow of sufficient aeration.

Unless gravity flows could be utilized, it is probable that the double pumping costs would cause this arrangement to be regarded with disfavor from a practical, operating viewpoint.

GENERAL SUMMARY

1. The gradual evolution of sewage treatment as related to the development of the sprinkling filter is traced.

2. The theory of sewage purification in general and the various theories of the mechanism of purification by filtration are discussed.

3. A new conception of the mechanism of the purification process is proposed, based on an equilibrium between (a) the adsorption, by the film, of colloids and soluble substances which lower the surface tension of water and (b) the decomposition and oxidation of these substances by enzymes, bacteria, etc. Consideration of the oxygen requirements of the film emphasizes the necessity for intermittency.

4. The theoretical aspects of the relation of the depth of filter to the degree of purification indicate that the rate of purification should decrease with depth of filter. The literature on this subject is reviewed.

5. Experimental data support the conclusion that there is a definite depth of filter (in this case, six feet) beyond which the rate of purification is negligible.

6. Very deep filters cannot be dosed at rates strictly proportional to their depth because of the limiting factors of aeration, ponding and clogging.

7. The advantages of a six-foot filter over a ten-foot filter of the same cubic contents, from the standpoint of most effective utilization of a given amount of filtering medium, are pointed out.

8. The theoretical advisability of filtering through a coarse medium and then through a fine medium is mentioned.

APPENDIX TO PART I

TABLE XX.—ANALYTICAL DATA FROM DIFFERENT LEVELS IN SPRINKLING FILTER.

Series B.

Laboratory numbers	Date 1925	Day	Flow MGD				Temperature °C				cc flow per spray				Turbidity				Suspended Solids				Oxygen Consumed				Ammonia Nitrogen										
			Ar.	10 am	2 P.	4 P.	Infl.	Effl.	2 ft.	4 ft.	6 ft.	8 ft.	Infl.	2 ft.	4 ft.	6 ft.	8 ft.	Infl.	2 ft.	4 ft.	6 ft.	8 ft.	Infl.	2 ft.	4 ft.	6 ft.	8 ft.	Infl.	2 ft.	4 ft.	6 ft.	8 ft.	Infl.	2 ft.	4 ft.	6 ft.	8 ft.
53330-35	3/12	Thur.	2.5	3.0	4.5	9.5	—	—	1400	1280	800	1500	150	100	70	50	35	35	70	22	37	—	19	—	25	27	12	16	21	12	500	340	60	2.0	5.6	6.0	
53443-48	3/26	Thur.	3.0	3.3	2.8	17.8	11.0	11.0	1300	210	460	970	70	45	—	—	33	30	36	24	—	16	90	40	30	25	30	20	20	18	100	100	30	6.7	2.4	2.4	
53494-99	4/2	Thur.	3.2	4.1	—	16.1	11.0	11.0	460	550	200	1040	125	50	120	15	25	35	73	31	213	19	85	85	48	24	28	18	22	20	180	100	30	40	1.6	2.4	
53565-70	4/9	Thur.	4.5	5.5	11.1	18.4	12.0	14.0	180	210	580	660	130	125	45	20	75	100	55	248	400	51	380	578	35	38	28	24	28	56	240	128	28	1.2	1.8	1.6	
53621-26	4/16	Thur.	2.5	3.0	3.9	19.5	12.5	13.5	130	160	900	500	150	110	220	30	70	140	78	300	990	70	248	303	64	97	96	35	75	64	160	96	9.2	3.6	2.6	2.6	
53690-95	4/23	Thur.	2.2	3.7	7.2	30.6	14.0	17.0	490	120	830	1060	140	150	120	—	140	200	79	286	564	2738	287	726	102	76	74	109	56	34	260	144	80	6.4	5.2	4.8	
53743-48	4/30	Thur.	3.3	3.7	2.2	10.0	12.5	13.0	670	270	1780	1200	100	70	70	50	35	30	46	203	480	699	139	390	59	80	104	55	60	67	19.2	12.0	9.6	10.0	6.4	4.8	
53799-04	5/7	Thur.	2.7	2.7	3.9	18.4	13.5	13.5	800	530	1440	1450	110	20	50	50	50	37	97	282	312	403	233	63	56	63	74	76	63	140	11.2	6.4	4.8	1.2	1.2		
53858-63	5/14	Thur.	2.1	2.8	5.0	23.4	15.0	17.0	740	490	650	2280	200	75	40	30	20	30	95	182	426	233	113	193	68	62	90	57	46	57	248	140	8.8	2.4	3.6	2.8	
53909-14	5/21	Thur.	2.1	2.5	1.28	33.9	16.0	18.0	1010	440	850	1560	120	50	40	30	30	30	61	161	166	141	88	175	60	62	55	41	53	57	248	11.2	2.6	2.8	2.2	1.8	
53977-82	5/28	Thur.	2.3	2.6	1.56	28.4	16.0	17.0	2080	770	580	2240	270	25	20	30	30	40	62	72	74	152	106	226	22	25	24	22	58	48	25.6	17.2	3.2	2.0	3.2	1.6	
54033-38	6/4	Thur.	1.8	2.4	2.06	40.0	18.5	21.0	1200	580	510	2080	200	95	65	60	40	50	—	—	—	—	—	—	—	76	41	52	78	74	34	33.6	16.8	2.8	1.8	3.4	3.0
54096-01	6/11	Thur.	2.0	2.5	1.78	36.7	17.0	18.5	1420	775	725	2150	125	50	45	55	50	60	—	—	—	—	—	—	—	54	53	38	52	28	35	19.2	9.8	2.4	2.0	2.6	1.2
54151-56	6/18	Thur.	2.1	2.6	1.22	31.2	21.0	22.5	1940	200	460	550	155	55	35	30	25	—	—	—	—	—	—	—	—	46	65	52	42	73	25	25.6	14.0	6.0	3.2	3.2	3.6
54227-32	6/25	Thur.	2.2	2.6	1.28	21.8	18.0	21.0	1600	1430	1060	1740	130	45	50	40	20	40	78	79	130	83	70	90	52	36	43	36	28	29	21.6	12.0	9.2	3.6	1.4	5.0	
54298-03	7/2	Thur.	2.4	2.8	2.12	39.5	19.5	21.0	1680	940	920	1720	210	25	100	70	50	30	102	58	136	93	79	88	47	45	55	43	39	35	440	13.6	11.0	2.8	2.2	3.2	
54372-77	7/9	Thur.	2.0	2.5	2.39	36.7	20.0	24.0	1100	930	640	1350	228	50	60	40	30	30	116	94	146	78	80	80	41	33	38	22	17	21	34.4	13.2	7.0	3.4	1.4	3.2	
54448-53	7/16	Thur.	2.0	2.1	1.78	28.9	20.5	23.5	840	640	960	1380	180	75	50	50	45	30	100	110	71	95	69	82	51	50	30	36	33	34	280	8.0	4.8	2.0	1.6	2.2	
54542-47	7/23	Thur.	2.2	2.5	1.39	33.4	20.0	22.0	860	1000	1440	1840	280	75	60	50	60	50	133	86	86	107	115	110	54	43	39	42	39	34	288	13.2	5.2	1.8	3.2	1.0	
54609-14	7/30	Thur.	2.1	2.6	1.61	21.2	20.0	21.0	1400	1420	700	1700	250	90	50	40	50	50	140	79	100	105	84	152	42	31	30	28	28	34	280	15.2	11.0	2.8	3.4	4.8	
54663-68	8/6	Thur.	2.0	2.5	2.00	35.0	20.5	22.0	1370	1260	530	1560	210	60	45	35	30	20	108	33	20	10	16	15	53	35	26	22	23	21	27.2	12.8	9.0	2.0	3.4	4.4	
54741-46	8/13	Thur.	2.3	2.5	1.61	27.2	21.0	22.5	2060	1400	1000	1720	160	90	70	60	55	60	111	22	17	11	9	10	38	38	38	22	46	26	19.2	4.4	4.8	1.2	1.4	2.2	

TABLE XX.—Concluded.

Laboratory numbers	Date	Albuminoid Nitrogen					Total Organic Nitrogen					Nitrate Nitrogen					Nitrite Nitrogen					pH					Percent Stability										
		Inf.	2 ft.	4 ft.	6 ft.	8 ft.	Inf.	2 ft.	4 ft.	6 ft.	8 ft.	Inf.	2 ft.	4 ft.	6 ft.	8 ft.	Inf.	2 ft.	4 ft.	6 ft.	8 ft.	Inf.	2 ft.	4 ft.	6 ft.	8 ft.	Inf.	2 ft.	4 ft.	6 ft.	8 ft.						
53330-35	3/12	6.8	1.6	0.8	0.4	1.1	1.3	—	—	—	—	1.3	1.4	2.4	8.0	10.8	8.0	3.5	3.5	3.5	5.5	6.0	6.0	7.4	7.8	7.8	7.8	7.6	11	11	11	66	90	90	90	90	
53443-48	3/26	1.2	1.2	0.8	0.8	1.6	1.2	1.50	1.50	7.0	5.3	3.6	7.6	4.2	3.2	3.2	8.0	11.2	11.2	6.5	7.0	5.5	6.0	1.5	3.0	7.6	7.4	7.7	7.7	7.6	7.5	21	87	90	90	90	90
53494-99	4/2	5.2	1.7	1.4	1.4	1.7	1.4	9.0	7.0	4.0	3.0	5.4	5.6	1.4	3.2	11.2	10.0	10.4	11.6	3.5	3.5	3.5	5.0	4.5	5.5	7.5	8.0	8.0	8.2	7.8	7.6	11	37	90	90	90	90
53565-70	4/9	2.0	2.6	0.6	0.6	1.2	1.2	11.0	9.7	6.2	4.8	12.2	12.4	1.6	6.0	10.4	11.2	11.2	13.6	4.5	6.0	6.0	3.5	4.0	3.5	7.6	8.0	8.0	8.0	8.0	7.7	11	75	90	90	90	90
53621-26	4/16	4.0	3.8	6.4	1.6	3.6	5.8	16.5	12.9	15.8	9.4	7.4	4.9	2.4	4.8	12.0	10.0	23.2	25.6	5.5	7.5	7.5	5.5	5.0	5.5	7.6	7.8	7.8	7.7	7.4	11	75	90	90	90	90	
53690-95	4/23	4.8	6.4	5.6	16.8	4.4	5.6	16.5	13.1	14.5	33.6	9.8	7.7	2.0	5.2	12.0	9.6	13.2	10.0	3.5	9.5	12.0	7.0	1.25	8.0	7.4	7.7	7.7	7.7	7.6	11	50	90	11	90	90	90
53743-48	4/30	8.0	6.0	7.2	6.4	7.2	8.0	26.8	10.4	13.6	10.8	5.6	7.2	2.2	6.4	6.4	8.0	13.6	15.2	0.0	11.5	1.50	1.35	1.25	1.00	7.5	8.0	8.0	8.2	8.2	8.0	11	50	90	90	90	90
53799-04	5/7	1.2	1.6	2.4	4.0	6.4	3.6	6.0	8.8	13.6	5.2	8.8	8.8	12	6.0	12.8	11.2	22.0	15.6	1.5	11.5	1.80	1.10	1.05	8.5	7.6	8.0	8.2	8.2	8.0	11	80	90	90	90	90	
53858-63	5/14	4.0	3.2	6.0	3.6	3.2	4.8	12.4	12.0	9.2	3.6	2.4	5.2	0.4	5.2	8.8	16.0	14.0	14.0	3.0	11.5	2.60	1.60	1.90	1.60	7.4	8.0	7.9	8.0	8.0	7.8	11	50	90	90	90	90
53909-14	5/21	3.6	5.6	5.6	3.0	3.2	4.4	35.2	16.8	7.4	8.4	9.8	7.8	11	8.2	13.6	11.2	10.0	15.6	1.25	1.80	2.60	1.70	1.60	7.0	7.4	7.8	7.8	7.8	7.7	11	80	90	90	90	90	
53977-82	5/28	6.8	3.2	4.2	3.2	3.2	2.4	14.4	2.8	2.8	4.0	8.8	6.4	0.8	4.8	13.6	13.6	14.0	16.0	2.2	1.20	2.90	1.60	1.70	1.40	7.4	7.8	7.8	7.8	7.7	11	11	90	90	90	90	
54033-38	6/4	4.8	4.6	2.4	3.2	3.0	3.4	—	—	—	—	—	—	—	0.3	6.8	20.0	17.6	16.0	20.4	0.0	3.20	3.00	2.10	3.10	1.90	—	—	—	—	—	—	—	—	—	—	
54096-01	6/11	2.4	3.2	2.6	2.2	1.6	2.6	—	—	—	—	—	—	—	—	—	—	—	—	0.7	1.35	1.70	1.80	1.35	7.0	—	—	—	—	—	—	—	—	—	—		
54151-56	6/18	4.8	3.6	3.4	2.8	2.8	4.0	—	—	—	—	—	—	—	0.1	6.0	—	—	12.8	—	0.0	1.50	1.70	1.20	2.28	1.28	—	—	—	—	—	—	—	—	—	—	
54227-32	6/25	3.2	3.4	4.0	3.0	2.0	2.6	16.4	22.0	10.8	9.2	10.6	7.8	13	5.0	8.8	16.0	13.2	12.0	2.0	3.36	3.00	1.80	2.90	1.90	7.3	8.2	8.2	8.2	8.2	8.2	11	84	87	90	90	90
54298-03	7/2	5.2	3.4	4.8	3.2	4.0	2.8	8.0	18.4	8.2	15.6	13.8	20.8	1.0	8.0	12.8	20.0	1.80	1.80	0.0	1.80	1.60	1.30	1.40	1.50	7.1	7.8	7.8	7.8	7.8	7.8	11	75	80	90	90	90
54372-77	7/9	4.4	3.8	7.0	2.6	3.0	3.0	15.6	18.8	18.6	9.4	9.8	15.2	1.5	7.6	12.0	16.0	11.2	12.8	0.0	3.20	2.60	2.90	2.50	2.40	7.1	7.8	7.8	7.8	7.7	11	75	90	90	90	90	
54448-53	7/16	4.0	4.6	2.8	3.2	3.0	12.0	14.0	7.2	5.2	6.4	5.0	0.4	9.0	13.6	12.8	14.0	15.6	0.0	3.50	2.62	2.12	1.75	1.75	7.1	7.8	7.8	7.8	7.8	7.8	11	84	90	90	90	90	
54542-47	7/23	4.0	3.2	2.8	3.2	3.6	3.6	15.2	18.8	9.2	3.8	4.8	5.4	0.4	2.2	5.2	9.6	9.2	14.4	0.0	3.17	1.87	1.00	1.25	1.12	7.1	7.8	7.8	7.8	7.8	11	75	90	90	90	90	
54609-14	7/30	3.4	4.4	3.8	3.2	3.0	4.4	4.0	8.8	4.2	4.4	8.6	7.2	0.2	7.6	8.8	14.0	13.6	14.0	0.0	5.00	3.75	1.25	2.12	1.75	7.1	7.8	7.8	7.8	7.8	11	84	90	90	90	90	
54663-68	8/6	3.2	2.0	1.8	0.8	1.2	1.0	6.8	5.2	0.6	2.8	3.8	2.0	0.4	6.4	8.8	13.6	16.8	12.8	0.0	3.75	2.87	1.50	3.00	1.87	7.1	7.8	7.8	7.8	7.8	11	80	90	90	90	90	
54741-46	8/13	3.2	1.8	1.8	1.4	0.8	1.8	2.8	13.6	0.8	6.0	0.0	1.8	0.4	3.6	5.2	8.0	9.6	6.4	1.0	7.50	4.50	1.00	1.00	1.00	7.1	7.8	7.8	7.8	7.8	11	75	90	90	90	90	

DEPTH OF SEWAGE FILTERS

TABLE XXI.—ANALYTICAL DATA FROM DIFFERENT LEVELS IN SPRINKLING FILTER.

Series C.

Laboratory numbers	Date 1925	Day	Flow MG			Temperature °C			cc. flow per spray								Turbidity								Suspended Solids								Oxygen Consumed								Ammonia								Nitrogen							
			Ave.	4 ft.	8 ft.	Air	215	210	Infl.	Effl.	2 ft.	4 ft.	6 ft.	8 ft.	Infl.	2 ft.	4 ft.	6 ft.	8 ft.	Effl.	Infl.	2 ft.	4 ft.	6 ft.	8 ft.	Effl.	Infl.	2 ft.	4 ft.	6 ft.	8 ft.	Effl.	Infl.	2 ft.	4 ft.	6 ft.	8 ft.	Effl.	Infl.	2 ft.	4 ft.	6 ft.	8 ft.	Effl.												
53338-43	3/12	Thur	2.5	2.0	4.5	9.5	10.0	—	840	1260	380	600	180	120	110	55	35	40	99	40	47	—	—	28	45	35	42	35	28	34	500	480	500	140	68	80																				
53451-56	3/26	Thur	3.0	3.5	2.8	17.8	12.5	12.5	1210	120	600	1100	130	65	—	40	65	65	61	31	—	17	98	73	50	30	50	32	38	28	160	60	60	40	16	24																				
53508-13	4/2	Thur	3.2	3.2	-1.1	16.1	12.5	11.0	460	150	630	1650	210	100	—	80	80	110	105	70	—	82	129	89	50	38	30	28	33	34	300	152	40	24	24	24																				
53571-76	4/9	Thur	4.5	4.6	11.1	18.4	13.5	13.0	160	220	710	950	190	110	95	45	45	110	149	284	152	58	40	260	68	51	36	24	31	68	240	280	32	16	32	26																				
53635-40	4/16	Thur	2.5	2.4	3.4	14.5	14.5	12.5	150	230	900	450	200	140	250	35	110	150	162	342	872	45	338	487	84	86	153	45	68	87	240	208	92	48	24	46																				
53703-08	4/23	Thur	2.2	2.5	17.2	30.6	17.0	16.5	450	100	580	930	170	200	130	240	140	140	126	246	532	1316	380	430	93	100	77	106	92	107	220	280	52	56	52	28																				
53753-58	4/30	Thur	3.3	3.7	2.2	10.0	15.0	12.0	630	260	1100	1260	170	100	120	60	50	60	101	118	446	211	114	368	82	70	86	73	54	64	340	160	152	17.6	64	160																				
53809-14	5/7	Thur	2.7	3.3	3.4	18.4	16.0	13.0	850	400	850	1430	170	100	75	50	15	35	104	92	165	232	128	213	72	48	51	55	44	51	192	160	92	52	1.6	3.6																				
53864-74	5/14	Thur	2.1	2.6	5.0	23.4	17.0	16.0	700	350	800	1660	220	75	40	40	30	40	88	145	70	195	87	133	80	54	47	58	36	44	240	128	48	40	24	36																				
53923-28	5/21	Thur	2.1	3.0	12.8	33.4	18.0	17.5	1600	440	615	1710	200	100	60	40	40	40	123	151	285	141	137	180	88	80	77	68	75	64	200	100	52	52	24	16																				
53984-44	5/28	Thur	2.3	2.7	15.6	28.4	18.0	16.5	2120	530	570	2020	240	50	20	20	20	20	79	65	105	144	86	168	80	52	41	63	48	47	256	120	2.0	1.6	60	40																				
54108-13	6/11	Thur	2.0	2.7	17.8	36.7	18.0	19.0	2090	800	930	2735	240	50	75	75	60	90	—	—	—	—	—	—	—	—	—	—	—	—	—	—	—	—	—	—	—	—																		
54162-67	6/18	Thur	2.1	2.5	12.2	31.2	21.0	22.0	1520	360	760	370	310	75	40	30	30	60	—	—	—	—	—	—	—	—	—	—	—	—	—	—	—	—	—	—	—	—																		
54238-43	6/25	Thur	2.2	2.3	12.8	21.8	19.0	19.5	1200	1100	880	1340	200	40	50	40	30	30	73	67	69	70	65	83	68	48	44	41	36	41	256	104	70	2.8	2.0	34																				
54310-15	7/2	Thur	2.4	2.1	21.2	31.5	21.0	22.0	1340	800	740	1760	245	50	80	20	20	20	119	81	90	64	62	112	70	46	46	37	36	44	256	112	5.4	1.2	24	28																				
54382-87	7/9	Thur	2.0	2.5	23.4	36.7	21.5	23.5	1040	650	680	1410	230	40	60	40	40	40	128	48	79	63	75	64	50	41	32	25	27	30	224	104	7.0	6.4	1.0	2.0																				
54456-61	7/16	Thur	2.0	2.5	17.8	28.4	21.0	23.5	1000	740	1020	1280	280	75	75	60	60	65	167	84	88	91	80	91	65	51	43	43	41	46	280	60	2.8	3.4	2.0	3.0																				
54550-55	7/23	Thur	2.2	2.6	13.4	33.4	21.0	21.0	1200	660	480	1280	175	65	70	55	55	73	94	93	83	70	106	64	51	45	38	37	34	256	120	3.0	8.8	1.6	2.0																					
54617-22	7/30	Thur	2.1	2.2	16.1	21.2	20.0	20.0	1180	1020	420	1350	310	70	70	60	60	114	94	94	82	80	72	55	35	32	28	25	22	288	120	6.0	2.0	3.0	2.0																					
54671-76	8/6	Thur	2.0	2.6	20.0	35.0	21.5	21.5	—	—	—	—	220	70	40	35	35	25	82	12	15	16	3	5	63	41	37	32	29	28	256	92	12.0	5.0	6.0	44																				
54744-54	8/13	Thur	2.3	2.7	16.1	27.2	21.0	22.5	1320	1100	580	1300	200	55	30	23	25	20	114	18	19	20	7	10	55	37	26	30	26	27	192	96	3.6	0.8	2.0	24																				

TABLE XXL—Concluded.

Laboratory numbers	Date 1925	Albuminoid Nitrogen					Total Organic Nitrogen					Nitrate Nitrogen					Nitrite Nitrogen					pH					Percent Stability											
		inf.	2 ft.	4 ft.	6 ft.	8 ft.	inf.	2 ft.	4 ft.	6 ft.	8 ft.	inf.	2 ft.	4 ft.	6 ft.	8 ft.	inf.	2 ft.	4 ft.	6 ft.	8 ft.	inf.	2 ft.	4 ft.	6 ft.	8 ft.	inf.	2 ft.	4 ft.	6 ft.	8 ft.							
53338-43	3/12	10.4	6.8	6.8	1.2	1.6	1.2	—	—	—	—	—	—	—	—	0.9	0.9	1.1	1.0	1.3	1.6	2.5	2.0	2.5	5.5	7.5	7.5	7.4	7.8	7.8	7.8	7.6	11	11	11	68	90	90
53451-56	3/26	1.6	1.2	1.2	0.8	0.8	5.0	12.0	6.0	5.0	3.8	4.7	2.3	1.2	2.8	6.0	10.4	10.4	6.5	7.0	5.5	9.0	8.0	1.05	7.8	8.2	8.1	8.1	8.1	7.9	11	11	30	90	90	90		
53508-13	4/2	3.6	2.8	1.6	2.8	2.4	3.0	8.0	8.8	1.0	3.6	4.6	3.6	1.5	1.6	14.4	10.8	10.0	10.4	5.5	2.5	6.5	7.0	7.5	6.5	7.8	8.2	7.6	8.2	8.0	8.0	11	11	90	90	90	90	
53571-76	4/9	3.2	3.2	2.8	1.2	1.2	3.6	6.0	12.0	11.8	5.4	2.8	6.4	0.9	3.0	11.2	3.6	14.0	12.4	5.0	5.5	7.0	4.0	7.0	5.5	7.6	8.0	7.8	7.8	7.8	7.6	11	30	90	90	90	90	
53635-40	4/16	4.8	7.6	12.0	3.0	5.2	9.6	16.0	4.2	28.3	0.2	7.6	12.9	1.1	5.8	25.0	36.0	18.0	22.4	2.5	3.0	8.0	5.0	3.0	6.5	7.6	7.8	7.7	7.7	7.6	7.3	11	44	60	90	90	90	
53703-08	4/23	4.8	6.0	5.6	11.6	3.2	6.0	15.5	2.0	—	24.4	7.3	17.2	1.1	4.8	12.0	10.8	14.8	14.0	1.5	1.0	1.2	1.0	1.2	1.0	7.4	7.6	7.6	7.6	7.5	11	30	87	44	90	90		
53753-58	4/30	9.6	10.4	13.6	6.4	4.8	9.6	10.0	32.0	32.8	14.4	1.6	4.0	0.8	4.6	8.8	7.2	13.6	13.6	0.0	8.5	1.05	8.5	1.55	3.90	7.5	8.0	8.0	8.0	8.0	7.8	11	30	90	80	90	90	
53809-14	5/7	4.6	3.4	3.6	3.8	3.0	3.2	16.8	8.0	4.8	6.8	4.4	4.4	0.3	4.6	10.0	15.2	17.6	16.0	0.0	8.5	1.80	1.55	1.70	1.45	7.3	7.8	7.8	7.8	7.8	7.6	11	11	80	90	90	90	
53869-74	5/14	4.8	4.4	3.4	4.0	3.4	3.6	10.0	9.6	7.2	8.0	7.2	8.4	0.0	4.4	13.6	16.4	12.8	15.6	0.0	1.25	3.60	2.70	1.50	1.45	7.4	7.8	7.8	7.8	7.7	11	44	90	90	90	90		
53923-28	5/21	5.2	4.4	4.0	3.2	4.0	4.4	12.0	12.0	5.2	1.2	5.6	6.4	0.8	4.8	15.2	14.4	13.2	14.8	0.0	1.50	1.90	1.20	1.10	2.5	7.3	7.8	7.8	7.8	7.8	11	11	90	90	90	90		
53984-94	5/28	4.8	3.2	2.6	3.2	2.4	3.2	14.4	8.0	6.0	6.4	6.0	4.0	0.0	5.6	16.8	17.6	15.6	22.0	0.0	8.0	1.80	1.45	1.80	1.25	7.4	7.8	7.8	7.8	7.7	11	11	90	90	90	90		
54041-46	6/4	4.8	2.2	2.8	2.6	2.4	3.0	—	—	—	—	—	—	—	0.2	4.4	6.4	8.0	9.6	—	0.0	1.90	1.35	7.0	1.05	9.0	—	—	—	—	—	—	—	—	—	—		
54108-13	6/11	5.2	3.8	3.0	3.2	3.0	3.6	—	—	—	—	—	—	—	—	—	—	—	—	—	0.0	1.70	5.60	1.90	3.00	2.80	—	—	—	—	—	—	—	—	—	—	—	
54162-67	6/18	4.8	3.6	2.8	3.4	3.2	3.0	—	—	—	—	—	—	—	2.2	5.6	16.8	15.2	22.0	7.2	0.0	1.90	2.30	1.70	1.8	1.15	—	—	—	—	—	—	—	—	—	—	—	
54238-43	6/25	4.4	3.6	3.4	2.4	2.4	2.8	22.4	17.6	7.4	10.0	9.2	13.4	1.2	6.6	8.0	14.4	16.8	18.4	0.2	3.00	2.00	1.60	1.60	1.50	7.4	8.2	8.2	8.2	8.2	11	21	30	90	90	90		
54310-15	7/2	4.8	3.6	4.4	3.6	3.0	5.4	14.4	20.8	10.6	22.8	10.4	14.8	0.5	8.0	13.2	15.6	14.8	20.0	0.0	2.70	2.90	1.80	2.70	2.20	7.1	7.8	7.8	7.8	7.8	11	21	90	90	90	90		
54382-87	7/4	4.6	2.8	3.6	2.8	3.2	2.8	21.6	54.4	25.0	21.6	16.6	11.6	1.1	8.0	15.2	16.8	18.0	17.6	0.0	3.12	2.50	1.50	1.87	1.87	7.1	7.8	7.8	7.8	7.6	11	60	90	90	90	90		
54456-61	7/16	3.6	4.8	2.8	3.2	2.6	4.0	2.0	14.0	7.6	10.2	8.4	9.0	0.5	9.0	18.8	17.6	16.0	18.0	0.0	3.37	2.37	2.75	1.87	1.87	7.1	7.8	7.8	7.8	7.8	11	60	90	90	90	90		
54550-55	7/23	3.2	3.2	4.8	3.0	3.4	4.2	8.4	4.0	4.2	4.0	5.6	2.8	0.4	5.6	10.0	7.6	8.4	10.0	0.0	3.37	1.75	6.2	1.12	1.12	7.1	7.8	7.8	7.8	7.8	11	21	90	90	90	90		
54617-22	7/30	3.6	5.6	4.0	2.4	5.0	1.8	19.2	6.0	6.0	4.4	15.0	4.4	0.2	5.2	8.0	7.2	11.2	8.0	0.0	4.00	3.12	1.62	1.37	1.62	7.2	8.0	8.0	8.0	8.0	11	75	90	90	90	90		
54671-76	8/6	3.2	1.8	2.6	1.8	0.8	1.0	2.4	6.8	4.8	3.8	2.0	4.0	1.3	4.4	3.6	6.4	6.4	6.4	0.0	3.12	1.87	1.75	1.62	1.75	7.1	7.8	7.8	7.8	7.8	11	50	50	90	90	90		
54749-54	8/13	2.6	1.6	1.8	1.2	0.8	1.4	12.8	8.4	0.4	0.0	0.4	5.6	0.3	4.8	12.0	13.6	11.2	11.2	0.0	5.50	2.50	0.0	0.0	2.00	7.1	7.8	7.8	7.8	7.8	11	30	90	90	90	90		

DEPTH OF SEWAGE FILTERS

TABLE XXIII.—ANALYTICAL DATA FROM DIFFERENT LEVELS IN SPRINKLING FILTER.

Series E.

Laboratory numbers	Date 1925	Day	Flow MGD		Temperature °C				cc. flow per spray				Turbidity				Suspended Solids				Oxygen Consumed				Ammonia				Nitrogen									
			Av	Vol	Min	Max	Infl	Effl	2 ft	4 ft	6 ft	8 ft	Infl	2 ft	4 ft	6 ft	Infl	2 ft	4 ft	6 ft	Infl	2 ft	4 ft	6 ft	Infl	2 ft	4 ft	6 ft	Infl	2 ft	4 ft	6 ft						
54864-69	6/27	Thurs	2.0	2.6	13.9	26.7	20.5	22.0	—	—	—	—	170	100	50	40	30	45	86	340	91	64	244	356	69	43	35	26	28	34	28.8	16.6	9.6	6.4	6.7	6.6		
54872-77	6/28	Fri.	2.1	2.4	13.9	31.2	20.0	21.0	82.70	1840	2140	1900	150	90	65	35	35	30	65	106	346	96	133	156	55	45	27	30	44	30	21.6	20.8	6.0	3.2	5.0	3.2		
54881-86	6/29	Sat.	1.8	2.0	15.0	28.9	20.5	21.0	2840	5300	1600	2560	160	70	70	20	20	20	75	72	62	33	58	64	52	41	40	28	32	27	24.8	12.8	16.8	3.0	2.2	6.0		
54916-21	9/1	Tues.	2.0	2.7	15.6	30.6	20.5	22.0	1100	3320	4700	1760	200	50	70	40	30	30	126	980	147	72	52	59	61	—	30	28	20	29	26.4	8.0	18.0	11.0	3.4	5.6		
54946-51	9/2	Wed.	2.1	2.8	22.2	31.7	20.0	21.0	1360	3180	4260	1960	190	85	35	35	40	35	102	536	47	50	272	60	46	29	33	30	15	24	21.6	9.6	10.4	8.6	2.8			
54960-65	9/3	Thurs	2.1	2.7	18.4	33.9	20.5	22.0	1720	420	2160	1780	195	55	30	25	20	20	119	101	62	62	66	36	72	45	36	34	30	32	26.9	7.2	2.0	3.2	0.6	6.0		
54967-72	9/4	Fri.	2.0	2.6	16.1	32.8	21.0	22.5	2840	2000	1740	3900	170	55	60	50	55	50	104	158	149	73	156	151	75	58	48	45	38	33	27.2	12.8	8.4	3.0	8.4	5.2		
54982-87	9/7	Mon.	2.0	2.9	20.6	33.9	20.5	22.5	2200	1520	2420	2000	125	60	55	50	50	45	60	36	43	30	184	68	59	32	25	29	27	27	24.0	12.8	4.4	9.8	2.6	2.2		
54991-96	9/8	Tues.	2.6	2.8	19.5	26.7	20.5	22.5	5900	1320	1200	3160	150	85	40	30	35	30	—	—	—	—	—	—	—	57	43	32	20	26	20	26.4	20.0	6.4	3.4	6.6	4.6	
55034-39	9/11	Fri.	2.2	2.7	19.5	31.2	21.0	22.0	6750	2000	2300	5000	250	150	40	40	60	45	—	—	—	—	—	—	—	60	42	28	24	30	26	24.6	26.4	9.6	6.8	18.0	6.2	
55114-17	9/17	Thurs	3.6	3.6	17.2	24.5	20.0	20.5	—	—	—	—	160	75	—	—	30	30	—	—	—	—	—	—	—	—	—	—	—	—	—	—	—	—	—	—	17.2	16.0
55163-68	9/28	Mon.	3.2	3.5	11.7	25.6	20.0	20.0	1300	1090	2740	1960	170	65	95	45	30	68	80	48	55	63	57	52	27	29	27	29	27	29	26	35.2	12.0	8.0	16.8	1.4	12.0	
55220-25	9/30	Wed.	3.3	3.3	13.9	21.8	19.5	20.0	1320	1440	2180	2240	140	55	25	30	40	50	74	132	11	15	43	49	44	50	42	56	34	30	28.8	12.8	8.8	3.6	1.0	8.4		
55288-93	10/6	Tues.	3.5	3.3	3.9	13.9	18.0	18.5	1840	6000	6500	2600	70	40	15	15	15	16	452	26	73	58	47	39	25	23	19	19	24	24.0	9.6	11.2	9.6	4.0	12.0			
55311-16	10/7	Wed.	3.3	4.0	6.1	13.3	18.5	18.5	1000	4000	4000	1000	100	50	30	30	30	35	—	—	—	—	—	—	—	—	—	—	—	—	—	—	—	—	—	—	—	—
55335-40	10/9	Fri.	3.7	3.6	-33	6.6	18.0	17.0	1380	1220	3000	1220	50	20	15	15	15	15	—	—	—	—	—	—	—	—	—	—	—	—	—	—	—	—	—	—	—	

SERIES G

1 p.m.																																					
55347-40	10/14	Wed.	3.5	3.8	4.5	18.9	19.0	18.5	1020	670	570	1600	180	45	15	15	15	15	92	48	43	36	16	87	64	40	36	28	31	37	17.6	12.8	1.2	1.2	1.0	1.8	
55427-32	10/15	Thurs	3.3	3.8	4.5	14.5	18.5	17.5	860	450	720	1860	160	—	—	—	—	—	—	—	—	—	—	—	—	—	—	—	—	—	—	—	—	—	—	—	—
55446-51	10/19	Mon.	3.5	5.5	-1.7	5.0	13.5	13.4	1020	630	470	1500	200	80	45	40	40	40	560	73	25	158	69	47	34	26	34	32	31	24.0	14.4	2.0	6.0	2.8	5.0		
55458-63	10/20	Tues.	3.0	3.2	-1.1	7.8	17.0	13.0	1020	540	560	2000	230	55	40	40	40	40	101	49	44	37	59	100	78	43	47	35	36	40	20.8	11.2	2.8	2.8	2.8	4.4	
55493-98	10/22	Thurs	3.4	3.5	-1.1	8.2	17.5	14.5	1440	440	400	1200	150	45	30	30	30	30	—	—	—	—	—	—	—	—	—	—	—	—	—	—	—	—	—	—	—
55514-24	10/23	Tues.	3.1	4.0	-6.1	4.5	17.0	12.5	1400	410	510	1420	250	80	40	40	40	78	47	30	21	160	61	48	38	23	23	29	28	20.8	13.6	3.6	1.6	2.8	3.0		
55542-47	10/20	Fri.	3.0	3.9	-10.0	0.0	17.0	12.5	1500	420	350	1360	240	40	50	50	50	50	83	63	18	38	42	68	36	20	16	17	16	18	19.2	12.8	4.4	0.8	1.6	3.0	
55551-56	11/2	Mon.	3.0	3.9	-1.1	8.9	17.0	13.5	1840	340	310	1520	220	80	45	45	45	45	40	53	46	35	137	85	64	35	25	19	26	24	27.2	16.8	0.8	0.4	2.2	3.6	
55607-12	11/5	Thurs	3.2	4.0	0	14.5	17.0	15.5	1650	770	440	1330	200	75	40	40	35	40	70	32	37	35	80	72	45	21	23	19	19	26	25.6	13.6	7.2	1.2	0.4	5.2	
55617-22	11/6	Fri.	3.1	3.7	4.5	11.7	17.0	15.0	1530	760	200	1460	190	55	55	65	35	45	82	40	140	—	32	80	41	24	22	18	20	23	25.6	20.0	6.0	0.0	0.8	3.2	
55628-33	11/9	Mon.	3.4	4.0	0	6.6	14.5	10.5	1460	920	360	1480	190	65	50	45	40	55	89	64	54	30	105	94	30	23	18	11	12	12	15.2	5.6	3.2	3.6	3.4	4.4	
55664-74	11/11	Wed.	3.7	4.8	-1.1	13.3	16.0	13.0	1420	1100	350	1680	160	55	35	35	25	50	—	—	—	—	—	—	—	—	—	—	—	—	—	—	—	—	—	—	—

TABLE XXIII.—Concluded.

Laboratory numbers	Date 1925	Albuminoid Nitrogen					Total Organic Nitrogen					Nitrate Nitrogen					Nitrite Nitrogen					pH					Percent Stability										
		Inf.	2 ft.	4 ft.	6 ft.	8 ft.	Inf.	2 ft.	4 ft.	6 ft.	8 ft.	Inf.	2 ft.	4 ft.	6 ft.	8 ft.	Inf.	2 ft.	4 ft.	6 ft.	8 ft.	Inf.	2 ft.	4 ft.	6 ft.	8 ft.	Inf.	2 ft.	4 ft.	6 ft.	8 ft.						
54864-69	8/27	3.8	2.4	1.7	1.5	1.9	2.1	—	4.4	6.7	3.8	3.5	3.4	0.8	3.6	7.2	7.2	12.0	11.6	0.00	2.00	2.60	1.37	1.50	1.00	7.0	7.7	7.7	7.6	7.6	7.6	11	90	90	90	90	
54872-77	8/28	2.4	2.6	2.0	1.1	1.9	1.2	3.2	3.2	2.8	2.8	4.2	2.8	0.4	2.4	5.6	8.0	9.2	9.6	0.02	0.75	1.97	0.87	0.87	0.87	7.1	7.7	7.8	7.6	7.8	11	90	90	90	90		
54881-86	8/29	2.8	2.0	1.9	1.1	1.1	1.3	6.4	6.6	3.2	—	3.4	—	0.3	4.0	2.8	6.0	4.8	7.2	0.00	3.00	1.80	1.00	1.00	1.40	7.0	7.7	7.7	7.7	7.7	11	75	90	90	90		
54916-21	9/1	3.6	2.1	1.8	1.4	3.0	1.4	8.0	2.4	2.8	5.0	6.2	0.6	0.4	10.6	6.0	5.6	12.0	6.8	0.01	5.00	3.12	1.50	1.37	1.62	7.1	7.8	7.6	7.6	7.8	11	90	37	90	90		
54946-51	9/2	4.6	2.7	1.9	1.6	1.4	1.8	12.0	7.2	1.6	3.2	5.0	10.0	0.4	7.0	4.4	3.2	10.4	4.0	0.00	2.75	2.00	1.50	1.00	1.25	7.1	7.7	7.8	7.6	7.9	11	30	90	87	90		
54960-65	9/3	4.0	1.9	1.8	1.2	1.1	1.3	4.8	7.2	5.2	2.4	4.6	5.2	0.4	5.0	9.6	7.2	12.8	4.8	0.00	2.62	1.50	1.50	0.62	2.12	7.0	7.8	7.8	7.6	7.8	11	90	90	90	90		
54967-72	9/4	3.6	2.4	1.7	1.4	1.7	1.4	6.0	7.2	3.6	5.8	4.4	6.4	0.2	3.2	9.6	4.2	4.8	8.8	0.00	3.25	2.75	1.50	1.75	2.00	7.0	7.7	7.8	7.6	7.9	11	37	90	90	90		
54982-87	9/7	4.6	2.2	2.1	1.4	1.4	1.2	3.2	—	4.4	4.0	3.8	3.8	—	—	—	—	—	0.00	3.00	1.75	1.50	1.75	1.62	7.0	7.8	7.8	7.6	7.7	11	21	90	90	90			
54991-96	9/8	3.0	2.2	1.8	1.3	1.4	1.4	—	—	—	—	—	—	—	0.4	2.6	—	14.8	6.8	9.6	0.00	2.62	2.50	1.37	2.62	2.62	—	—	—	—	—	11	21	90	90	90	
55034-39	9/11	5.6	2.4	1.3	2.9	2.9	1.4	—	—	—	—	—	—	—	0.3	3.2	9.2	13.2	7.6	13.2	0.00	3.00	3.00	3.00	2.87	2.87	3.00	—	—	—	—	—	—	—	—		
55114-17	9/17	3.0	2.2	—	—	1.8	1.4	8.0	1.6	—	—	8.0	5.2	0.4	0.6	—	—	3.6	3.2	0.00	0.30	—	—	0.50	0.40	7.0	7.7	—	—	7.7	7.7	11	21	—	—	7.8	7.8
55183-88	9/28	4.4	1.4	1.3	1.1	1.2	1.8	8.0	4.0	5.6	0.8	4.2	4.0	0.3	4.0	4.4	4.4	12.0	2.8	0.00	3.00	2.80	1.25	0.75	1.00	7.1	7.8	7.8	7.6	7.8	11	90	90	90	90		
55220-25	9/30	3.0	2.1	1.3	1.0	1.1	1.8	4.4	4.0	5.6	3.6	5.4	3.6	0.6	2.8	2.8	5.6	5.6	2.8	0.00	0.20	0.15	0.15	0.10	0.15	7.1	7.8	7.8	7.6	7.8	11	90	90	90	90		
55288-93	10/6	2.8	1.4	1.2	1.1	0.8	1.2	8.8	2.4	2.4	3.6	4.0	2.0	0.4	2.4	3.6	4.0	3.6	3.6	0.25	1.50	1.10	1.10	0.25	0.60	2.2	7.8	7.8	7.6	7.8	11	90	90	90	90		
55311-16	10/7	2.6	2.1	1.6	1.2	1.1	1.4	17.6	4.0	2.4	3.2	4.2	3.4	0.2	1.6	3.2	4.4	3.6	4.8	0.60	0.75	0.60	0.75	0.65	0.65	7.2	7.8	7.6	7.8	7.6	7.7	11	44	90	90	90	
55335-40	10/9	3.0	2.0	0.9	0.7	0.6	1.3	7.2	8.0	4.4	3.4	4.0	8.4	0.0	3.8	8.8	6.0	1.00	9.6	0.00	1.50	1.25	1.50	0.00	1.50	7.3	7.8	7.8	7.6	7.7	11	90	90	90	90		
SERIES G																																					
55347-40	10/19	2.8	1.1	2.1	1.4	1.4	1.6	15.2	6.4	6.0	2.0	1.0	5.0	0.0	6.4	6.0	2.0	1.0	5.0	1.50	1.00	1.00	1.00	1.00	1.00	7.2	7.8	7.8	7.6	7.8	11	50	90	90	90		
55427-32	10/15	4.4	3.2	1.6	1.2	1.4	1.4	—	—	—	—	—	—	—	0.2	—	—	12.8	14.4	12.8	—	—	—	—	—	—	7.3	7.8	7.8	7.6	7.8	11	—	—	—	—	
55446-51	10/19	3.4	3.4	2.0	1.1	2.8	2.2	15.2	0.8	2.0	2.8	2.4	4.2	0.3	3.6	10.0	10.0	13.2	10.0	0.00	0.40	0.60	0.25	0.15	0.10	7.2	7.8	7.8	7.6	7.8	11	80	90	90	90		
55458-63	10/20	4.4	2.0	2.0	1.1	1.6	2.0	6.4	2.4	2.8	3.6	3.2	2.8	0.1	4.0	10.4	10.4	12.8	12.8	0.00	0.80	0.40	0.80	0.50	0.50	7.2	7.8	7.8	7.6	7.8	11	87	90	90	90		
55493-98	10/22	2.2	2.1	2.0	3.4	1.8	1.8	10.4	—	5.2	3.2	6.0	12.4	0.3	4.8	11.8	18.4	14.0	10.0	0.00	1.30	0.15	0.30	0.20	0.55	7.2	7.8	7.8	7.6	7.8	11	—	—	—	—		
55514-24	10/27	4.2	1.4	1.8	1.1	1.4	1.3	6.4	3.2	2.8	3.6	3.6	5.0	0.0	4.2	13.2	8.8	9.6	13.2	0.00	1.25	0.45	0.75	0.78	0.85	7.3	7.8	7.8	7.6	7.8	11	37	90	90	90		
55542-47	10/30	3.2	1.8	1.7	1.4	1.1	13.6	6.4	2.8	4.4	3.2	5.8	0.4	4.8	9.6	16.8	12.4	8.8	0.00	1.50	0.90	0.60	0.60	0.80	2.3	7.8	7.8	7.6	7.8	11	60	90	90	90			
55551-56	11/2	3.6	2.0	2.0	1.2	1.8	1.8	10.4	3.2	6.4	4.8	3.0	2.4	0.0	4.0	10.8	10.0	10.0	0.00	1.50	0.15	0.25	0.25	1.05	2.3	7.8	7.8	7.6	7.8	11	30	90	90	90			
55607-12	11/5	1.4	1.8	2.0	1.9	1.8	2.2	7.2	7.2	0.8	4.4	5.2	2.0	0.3	3.2	7.2	9.2	14.8	13.2	0.00	1.10	0.35	0.40	0.35	0.40	7.3	7.8	7.8	7.6	7.8	11	50	90	90	90		
55617-22	11/6	4.4	2.1	1.8	1.3	1.4	1.8	—	—	—	—	—	—	—	0.2	3.0	10.8	18.0	10.0	9.6	0.00	0.90	0.25	0.05	0.25	0.30	7.3	7.8	7.8	7.6	7.8	11	75	90	90	90	
55628-33	11/9	3.4	1.8	1.3	1.2	1.9	2.0	3.2	5.6	4.6	2.6	1.8	1.2	1.6	4.0	8.0	10.0	6.4	6.0	0.00	1.25	0.30	0.15	0.20	0.25	7.3	7.8	7.8	7.6	7.8	11	50	90	90	90		
55669-74	11/11	3.2	1.4	2.6	1.2	1.1	1.8	—	—	—	—	—	—	—	0.2	2.8	5.6	8.0	5.2	13.6	0.15	0.85	0.65	0.10	0.15	0.20	—	—	—	—	—	—	—	—	—		

DEPTH OF SEWAGE FILTERS

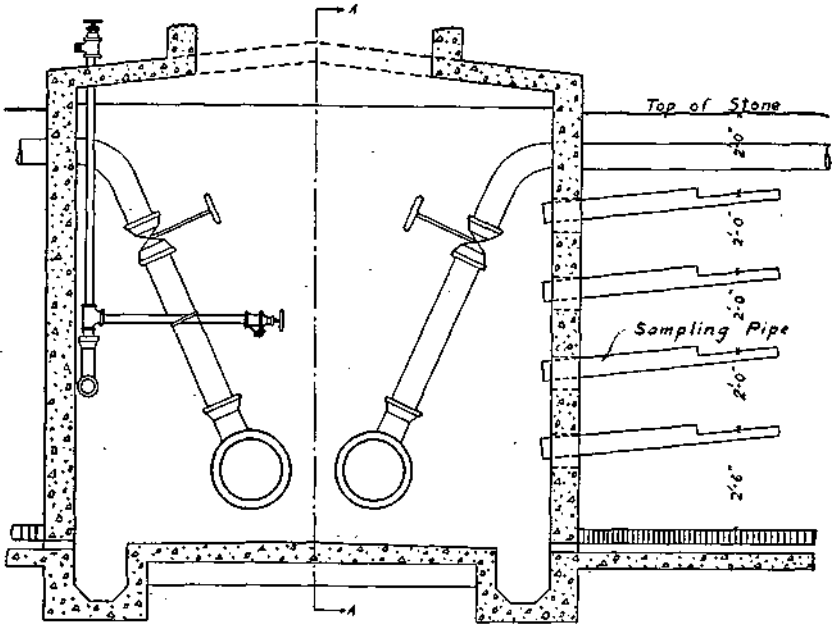

Section of
Gallery and Sampling Pipes

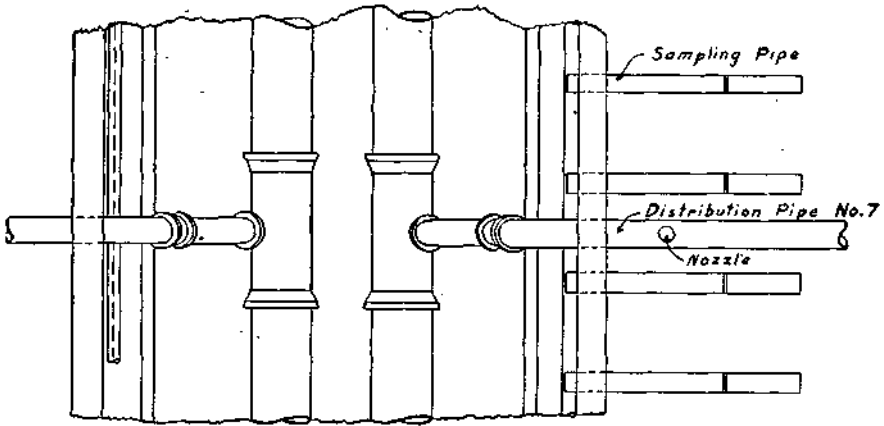

PLAN

FIG. 18.—INSTALLATION OF SAMPLING PIPES.

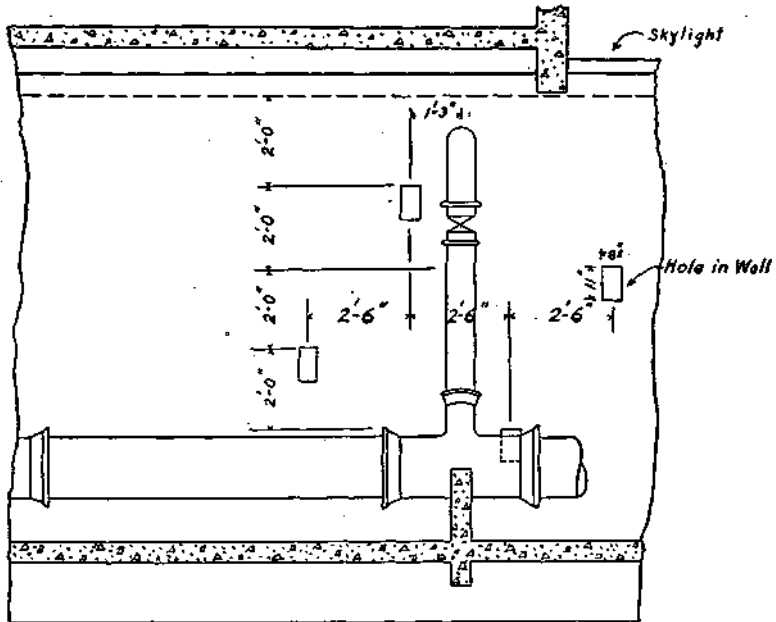

Section AA
Sampling Pipes Not Shown

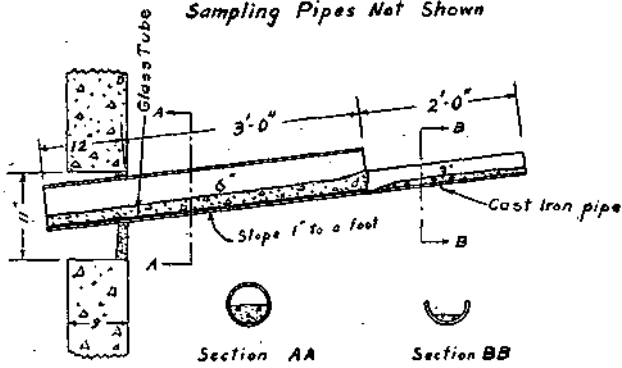

Detail of Sampling Pipe

FIG. 18.—(Concluded).

BIBLIOGRAPHY

- ¹ Mueller, A., "Sewage Disposal", Fuller, 616, (1912).
- ² Frankland, E., First Report River Pollution Commission (British), (1868).
- ⁸ Massachusetts State Board of Health Special Report, Purification of Water on Sewage 1890, 549.
- ⁴ Massachusetts State Board of Health Special Report, Purification of Water and Sewage 1890, 25.
- ⁵ Massachusetts State Board of Health Report, 1891, 555.
- ⁶ Waring, C. E. Jr., The Purification of Sewage by Forced Aeration. Newport, R. I., (1895).
- ⁷ Lowcock, S. R., Experiments on the filtration of sewage. Proc. Inst. Civ. Eng. CXV, 297, (1893). (Not seen).
- ⁸ Massachusetts State Board of Health Report, 1893, 422.
- ⁹ Massachusetts State Board of Health Report, 1895, 465.
- ¹⁰ Massachusetts State Board of Health Report, 1895, 469.
- ¹¹ Corbett, J., A dozen years of sewage purification experiments on a large scale at Salford, England. Eng. News 49, 191, (1903) see also *ibid* 48, 155, (1902).
- ¹² Stoddart, F. Wallis, Water analysis—the interpretation of results. Analyst, 19, (1894).
- ¹³ Dunbar, W. P., "Principles of Sewage Treatment", (1908).
- ¹⁴ Lederer, A., The relation of the putrescibility of the settling and non-settling suspended matter in sewage. Eng. Rec. 64, 733, (1911).
- ¹⁵ Massachusetts State Board of Health Report, 1891, 454.
- ¹⁶ Buswell, A. M., Importance of oxygen and stirring for activated sludge growth. Eng. News-Record 90, 835, (1923).
- ¹⁷ Marshall, C. E., "Microbiology". (1921).
- ¹⁸ Buswell, A. M., Biochemistry of the activated sludge process. Illinois State Water Survey Bull. 18, 69, (1923).
- ¹⁹ Robinson, R. H., Tartar, H. V., The decomposition of protein substances through the action of bacteria. J. Biol. Chem. 30, 135, (1917).
- ²⁰ Winslow, E. A., Phelps, E. B. Investigations on the purification of Boston sewage in septic tanks and trickling filters. Contributions from the Sanitary Research Laboratory and Sewage Experimental Station, M. I. T. 4, 387, (1908).
- ²¹ Mumford, E. M., The mechanism of nitrification. Proc. Chem. Soc. (London), 30, 36, (1914).
- ²² Clark, H. W., Adams, G. O., The influence of carbon upon nitrification. J. Ind. Eng. Chem. 4, 272 (1912).

- ²³ Chick, Harriette, A study of the process of nitrification with reference to the purification of sewage. Proc. Roy. Soc. (London), 77, Series B, 241, (1905-6).
- ²⁴ Adeney, W. E., App. VI to Fifth Report of British Royal Commission on Sewage Disposal, 27, (1908).
- ²⁵ Muntze, A., Laine, E., Recherches sur la nitrification intensive. Ann. Inst. Nat. Agronomique, 6, 15 (1907).
- ²⁶ Campbell, F. L., Rudolfs, W., Studies on the biology of sewage disposal. Report of sewage substation with N. J. Ag. Exp. Sta., Bull. 390, 28, (1923).
- ²⁷ Jones, A. S., Travis, W. O., The elimination of suspended solids and colloidal matter from sewage. Proc. Inst. Civ. Eng. CLXIV, Part II, 68, (1905-6).
- ²⁸ Travis, W. O., The Hampton Doctrine in relation to sewage purification. Surveyor, 34, 63, 625, (1908); 35, 7, (1909).
- ²⁹ Lubbert, A., The Hampton Doctrine in relation to sewage purification. Surveyor, 34, 575 and 598, (1908); 36, 109, (1909).
- ³⁰ Fowler, G. J., Gaunt, P., The interaction of dilute solutions of ammonium salts and various filtering media. J. Soc. Chem. Ind. 26, 740, (1907).
- ³¹ Stoddart, F. W., Nitrification and the absorption theory. - Seventh Int. Cong. App. Chem. Sec. VIIIA, 183, (1909).
- ³² Ardern, E., Sewage purification with reference to colloid chemistry. 2nd Report on Colloid Chem. (London), 81, (1921).
- ³³ Clifford, W., The time of passage of liquid through percolating beds. J. Soc. Chem. Ind. 26, 739, (1907); Proc. Inst. Civ. Eng, CLXXII, part II, 283, (1907-8.)
- ³⁴ Tatham, G. T. P., Some theoretical considerations bearing on the performance of biological sewage purification plants. J. Soc. Chem. Ind. 35, 711, (1916).
- ³⁵ Gibbs, J. Willard, Scientific Papers I, 219, (1906).
- ³⁶ Freundlich, H., "Kapillarchemie," 50, (1909).
- ³⁷ Landolt-Bornstein, Physikalish Chemische Tabellen.
- ³⁸ Quincke, Physio-chemical Tables, (1911).
- ³⁹ Ramsden, W., Abscheidung fester Körper in den oberflächenschichten von Lösungen und "Suspensionen." Zeit. Physik. Chem. 47, 336, (1904).
- ⁴⁰ Willows and Hatschek, "Surface Tension and Surface Energy," 46, (1915).
- ⁴¹ Lewis, W. C. McC, An experimental investigation of Gibbs' theory of surface-concentration, regarded as the basis of adsorption. Phil. Mag. 233, ser. 6, 17, 466, (1909), see also *ibid* April (1908).
- ⁴² Thompson, J. W., A study of the biology of the sprinkling sewage filter. N. J. Agr. Expt. Sta. Bull. 352, 25, (1921).

- ⁴³ Smith, Alex., "General Chemistry for Colleges," 180, (1913).
- ⁴⁴ Chick, H., An investigation of the laws of disinfection. *J. Hygiene*, 8, 92, (1908).
- ⁴⁵ Bartow, E., Mohlman, F. W., Purification of sewage by aeration in the presence of activated sludge. *J. Ind. Eng. Chem.* 7, 318, (1915); 8, 15, (1916).
- ⁴⁶ British Royal Commission on Sewage Disposal—Fifth Report, 70, (1908).
- ⁴⁷ Metcalf, L., and Eddy, H. P., "American Sewerage Practice." Vol. III, 561, (1916).
- ⁴⁸ Greeley, S. A., Discussion on "Some conclusions drawn from a recent survey of sewage treatment plants." *J. West. Soc. Eng.*, 27, 250, (1922).
- ⁴⁹ Report of the Baltimore Sewerage Commission, 59, (1911).
- ⁵⁰ Report of the Bureau of Surveys, Philadelphia, 7, (1911).
- ⁵¹ Clark, H. W., Massachusetts State Department of Health Report, 1915, 393.
- ⁵² Clark, H. W., Massachusetts State Department of Health Report, 1919, 108.
- ⁵³ Fuller, G. W., Economics of sewage filters. *Am. Soc. Mun. Imp.* 21, 113, (1914). Discussion of the economic depth of trickling filters. *J. Boston Soc. Civ. Eng.* 2, 63, (1915).
- ⁵⁴ Eddy, H. P., The economic depth of trickling filters. *J. Boston Soc. Civ. Eng.* 2, 49, 191, (1915).
- ⁵⁵ Smith, R. O., Annual Report Sewage Substation for year ending June 30, 1922. In Report of Department of Entomology of N. J. Ag. Coll. Expt. Sta. 487, (1923).
- ⁵⁶ Campbell, F. L., Rudolfs, W., Studies on the biology of sewage disposal. Report of Sewage Substation with N. J. Ag. Exp. Sta., Bull. 390, 18, (1923).
- ⁵⁷ Standard Methods of Water Analysis. A. P. H. A. (1923).

PART II

CONFIRMATORY DATA FROM EXPERIMENTAL TRICKLING FILTER

BY A. M. BUSWELL, E. L. PEARSON, AND G. E. STMONS

As a further demonstration of the relation of depth to purification by sprinkling filters, an experimental filter was constructed and operated for approximately a year (November, 1926 to October, 1927), at a rate of two million gallons per acre per day.

This filter was constructed as follows: A circular woodstave tank, 9½ feet in diameter and 10 feet deep, was divided into six equal segments by means of matched lumber partitions. Five of these segments were fitted with slat false bottoms 2, 4, 6, 8 and 10 feet from the top, respectively. These five segments were then filled with broken rock 1 by 2 inches. The sixth segment was filled with a special filter medium, the use of which had no connection with the present investigation. Arrangements were made to dose all six segments from a single nozzle placed in the center. (See page 91.)

The effluents from the different segments were discharged through separate 2-inch pipes into an annular cement trough which surrounded the filter. For the collection of samples, tubs were provided of sufficient volume to collect the entire effluent from each segment during a single dosing cycle. The contents of the tubs were stirred and a suitable portion taken for analysis. Samples were taken about three times a week, so timed that they would fall on different days of the week and at different times of the day.

After the filter had ripened sufficiently to show nitrification and purification, sampling was commenced on a schedule similar to that used by Strickhouser (page 43). The exact time of sampling is shown in Tables XXVIII-XXX. The data have been divided into three periods as follows: winter and early spring, January 3 to April 28 (46 samples); spring and summer, May 18 to August 17 (32 samples); and fall, August 22 to November 2 (21 samples). Tables XXIV-XXVI show the average values of the various determinations for these periods, respectively. The complete data are too voluminous to reproduce in detail, but the data for nitrates and oxygen consumed or B. O. D. have been tabulated for the convenience of any who wish to check the results.

The whole question of the chemistry of purification by trickling filters has been so completely treated in previous pages that detailed discussion of the data here presented is unnecessary. They show the same drop in efficiency as depth increases, with comparatively little further purification below the six-foot level.

TABLE XXIV.—AVERAGE ANALYSES OF EXPERIMENTAL TRICKLING FILTER SAMPLES.

46 Samples From 1/3/27 to 4/28/27.

	Inf.	2 ft.	4 ft.	6 ft.	8 ft.	10 ft.
pH.....	7.7	8.2	8.3	8.2	8.4	8.3
Settleable solids.....	.34	.18	.20	.24	.24	.32
Chloride, ppm.....	103.	98.	96.	97.	95.	98.
Residue, ppm.....	866.	817.	812.	849.	848.	840.
M. O. Alk., ppm.....	416.	397.	376.	361.	341.	345.
Nitrite nitrogen.....	.336	.94	1.12	1.26	1.37	1.89
Settling solids.....	96.7	57.7	66.7	103.3	89.6	68.3
Per cent stability.....	51.	68.	77.	86.	85.	88.
Turbidity.....	161.	107.	91.	95.	83.	75.
Per cent removal of turbidity.....		34%	43%	41%	48%	53%
Oxygen consumed.....	56.	36.	31.	29.	25.	25.
Per cent removal of oxygen consumed.....		36%	45%	48%	55%	55%
Nitrate nitrogen.....	1.73	2.81	3.75	5.22	6.41	5.77
Per cent conversion of NH ₃ nitrogen to NO ₃ nitrogen.....		6%	17%	29%	39%	33%
NH ₃ nitrogen.....	12.1	11.4	9.8	7.9	6.6	6.7
Per cent removal of NH ₃ nitrogen.....		6%	19%	35%	45%	45%
Organic nitrogen.....	3.54	2.14	2.097	2.15	2.93	2.62
Per cent removal of organic nitrogen.....		40%	41%	39%	17%	26%
Gooch solids.....	62.	55.	45.	38.	41.	34.
Per cent removal of gooch solids.....		11%	27%	39%	34%	45%
Sum of nitrogens.....	17.706	17.20	16.767	16.53	17.31	16.48

TABLE XXV.—AVERAGE ANALYSES OF EXPERIMENTAL TRICKLING FILTER SAMPLES.

32 Samples From 5/18/27 to 8/17/27.

	Inf.	2 ft.	4 ft.	6 ft.	8 ft.	10 ft.
pH.....	7.6	8.3	8.5	8.6	8.7	8.6
Settleable solids.....	.25	.07	.12	.12	.05	.03
Color.....	96	70	63	57	59	51
Residue.....	805	779	773	806	816	797
M. O., Alkalinity.....	408	361	329	319	317	307
Nitrite nitrogen.....	.255	1.21	1.22	1.01	.89	.80
Settling solids.....	59	51	57	60	73	59
Per cent stability.....	62	82	88	90	90+	90+
Turbidity.....	173	120	99	93	87	74
Per cent removal of turbidity.....		31	43	46	50	57
Oxygen consumed.....	44.3	26.7	22.9	23.9	21.7	19.3
Per cent removal of oxygen consumed.....		39.7	48.3	46.8	51	56.4
B. O. D.....	100	43	36	31	23	22
Per cent removal of B. O. D.....		57	64	69	77	78
Nitrate nitrogen.....	1.6	4.1	6.5	7.5	8.9	9.0
Per cent conversion of NH ₄ nitrogen to NO ₃ nitrogen.....		22	42	51	63	64
NH ₄ nitrogen.....	11.6	6.6	4.43	3.46	3.02	2.7
Per cent removal of NH ₄ nitrogen.....		43	62	70	74	76.7
Organic nitrogen.....	27.56	19.92	13.81	5.56	5.25	4.81
Per cent removal of organic nitrogen.....		27.7	50.0	80.0	80.4	84.0
Sum of nitrogens.....	41.02	31.83	25.96	17.53	18.06	16.81

DEPTH OF SEWAGE FILTERS

TABLE XXVI.—AVERAGE ANALYSES OF EXPERIMENTAL TRICKLING FILTER SAMPLES.

21 Samples From 8/22/27 to 11/2/27.

	Inf.	2 ft.	4 ft.	6 ft.	8 ft.	10 ft.	6 ft. cob
pH.....	7.7	8.2	8.2	8.1	8.2	8.2	8.2
Settleable solids.....	.25	.17	.26	.13	.08	.13	.05
Chloride, ppm.....	103.	100.	98.	100.	99.	95.	95.
Residue, ppm.....	790.	747.	758.	743.	747.	747.	702.
M. O. Alk., ppm.....	440.	403.	382.	317.	353.	348.	372.
Nitrite nitrogen.....	.131	.90	.94	.88	.74	.68	.32
Settling solids.....	40.	23.	24.	14.	12.	15.	7.5
Per cent stability.....		55.	64.	76.	77.	79.	79.
Turbidity.....	169.	115.	94.	76.	63.	53.	38.
Per cent removal of turbidity.....		32%	44%	55%	63%	69%	78%
Oxygen consumed.....	44.	27.	24.	20.	19.	17.	17.
Per cent removal of oxygen consumed.....		39%	45%	54%	57%	61%	61%
B. O. D. (17 samples).....	130.	91.	68.	64.	56.	49.	29.
Per cent removal of B. O. D. (17 samples).....		30%	48%	51%	57%	62%	78%
Nitrate nitrogen.....	2.0	4.7	6.3	8.3	9.1	10.1	3.9
Per cent conversion of NH ₃ nitrogen to NO ₃ nitrogen.....		20%	33%	48%	54%	61%	14%
NH nitrogen.....	13.2	10.0	9.1	7.2	7.2	5.6	5.4
Per cent removal of NH ₃ nitrogen.....		24%	31%	45%	45%	57%	59%
Organic nitrogen.....	55.6	55.8	41.5	41.2	30.6	28.0	22.2
Per cent of organic nitrogen.....		0%	25%	26%	45%	50%	60%
Sum of nitrogens.....	70.93	71.4	57.84	57.58	47.64	44.38	31.82

TABLE XXVII.—COMPLETE O₃ AND NO₂ DATA ON EXPERIMENTAL TRICKLING FILTER.

1/3/27 to 3/4/27.

Date.	Hour	Oxygen consumed						Nitrate nitrogen					
		Infl.	2 ft.	4 ft.	6 ft.	8 ft.	10 ft.	Infl.	2 ft.	4 ft.	6 ft.	8 ft.	10 ft.
Jan. 3, 1927	10 A. M.	86	63	58	43	34	36	0.7	1.5	1.75	3.0	4.0	3.5
Jan. 5, 1927	7 A. M.	36	26	26	21	18	20	1.5	2.25	2.25	4.0	4.0	3.5
Jan. 5, 1927	1 P. M.	88	62	52	39	39	29	0.85	1.25	1.25	2.25	4.5	4.5
Jan. 12, 1927	7 A. M.	26	19	18	16	15	1.75	2.0	2.25	4.0	4.0
Jan. 12, 1927	10 A. M.	85	60	54	50	33	34	0.7	1.75	2.0	4.5	3.0	1.5
Jan. 15, 1927	10 A. M.	80	49	44	32	26	27	1.75	2.0	2.50	4.00	6.0	5.5
Jan. 19, 1927	7 A. M.	25	14	15	28	18	13	1.75	2.0	2.50	5.0	4.5	3.0
Jan. 19, 1927	1 P. M.	91	65	40	49	38	39	0.85	2.0	2.0	4.00	2.75	1.75
Jan. 21, 1927	10 A. M.	68	30	44	35	33	31
Jan. 26, 1927	1 P. M.	84	55	49	39	25	26	0.6	2.25	2.0	3.0	3.0	1.75
Jan. 27, 1927	10 A. M.	83	58	53	48	35	31	0.85	2.5	2.0	4.0	2.75	2.5
Feb. 2, 1927	7 A. M.	24	22	24	21	17	19	1.5	2.5	2.25	3.0	2.75	4.5
Feb. 2, 1927	1 P. M.	52	33	25	21	18	16	2.25	3.25	6.0	5.0	5.0	6.0
Feb. 8, 1927	10 A. M.	60	33	31	31	24	21	1.75	2.0	2.25	3.5	4.0	3.5
Feb. 9, 1927	7 A. M.	28	18	14	14	6	15	2.25	2.0	2.0	3.0	2.5	3.0
Feb. 9, 1927	1 P. M.	68	33	31	30	30	34	2.25	2.5	5.0	6.0	5.0	6.0
Feb. 14, 1927	10 A. M.	40	24	18	17	16	19	3.0	3.0	5.0	4.5	6.0	6.0
Feb. 16, 1927	8 A. M.	52	47	40	30	27	23	2.0	3.0	4.0	5.0	5.0	4.5
Feb. 16, 1927	1 P. M.	63	27	16	16	12	13	1.0	1.7	1.7	2.0	5.5	6.0
Feb. 23, 1927	7 A. M.	24	15	16	15	13	11	3.0	4.5	6.0	6.0	6.0	9.0
Feb. 23, 1927	1 P. M.	72	35	32	20	17	22
Feb. 26, 1927	10 A. M.	67	37	24	21	17	22	2.0	3.4	7.0	8.0	12.0	7.0
Mar. 2, 1927	7 A. M.	35	24	23	24	38	33	2.8	3.40	4.00	7.0	9.0	8.0
Mar. 2, 1927	1 P. M.	82	59	53	46	48	57	0.80	3.4	4.00	8.00	12.00	9.00
Mar. 4, 1927	10 A. M.	82	60	42	30	34	33	2.0	2.0	2.8	6.	5.6	5.0

DEPTH OF SEWAGE FILTERS

85

TABLE XXVIII.—COMPLETE O₂ AND NO₃ DATA ON EXPERIMENTAL TRICKLING FILTER.

3/9/27 to 4/28/27.

Date	Hour	Oxygen consumed						Nitrate nitrogen					
		Infl.	2 ft.	4 ft.	6 ft.	8 ft.	10 ft.	Infl.	2 ft.	4 ft.	6 ft.	8 ft.	10 ft.
Mar. 9, 1927	7 A. M.	27	20	20	17	10	19	1.4	2.8	3.4	7.0	6.0	6.0
Mar. 9, 1927	1 P. M.	84	60	45	40	39	41	2.0	3.4	4.0	5.8	7.0	7.0
Mar. 10, 1927	10 A. M.	70	41	39	30	27	32	1.4	2.0	3.4	5.0	4.0	3.4
Mar. 16, 1927	7 A. M.	38	27	25	29	20	22	1.4	3.6	4.0	4.0	6.4	5.0
Mar. 16, 1927	1 P. M.	63	42	40	42	31	31	1.8	2.4	2.0	4.8	9.0	2.0
Mar. 22, 1927	10 A. M.	40	24	19	20	17	15	6.0	5.0	6.0	8.4	9.0	12.0
Mar. 23, 1927	7 A. M.	26	10	27	21	19	15	1.4	4.0	4.0	3.4	10.0	5.0
Mar. 23, 1927	1 P. M.	52	29	29	23	18	15	1.8	4.0	5.4	7.6	6.4	8.0
Mar. 30, 1927	7 A. M.	25	51	43	51	51	41	2.8	3.8	4.0	5.4	9.0	6.0
Mar. 30, 1927	1 P. M.	74	54	43	39	36	47	0.8	1.4	1.8	6.0	12.0	9.0
Apr. 4, 1927	10 A. M.	44	33	24	24	21	17	0.8	4.0	5.8	5.0	9.0	8.0
Apr. 6, 1927	7 A. M.	18	19	12	8	13	13	0.8	1.8	3.4	5.4	9.0	5.0
Apr. 6, 1927	1 P. M.	44	27	20	19	22	14	1.8	0.6	5.0	6.0	7.0	7.0
Apr. 13, 1927	7 A. M.	31	39	21	30	22	26	2.0	5.0	6.4	6.0	8.0	8.0
Apr. 13, 1927	1 P. M.	63	32	24	45	19	18	2.0	5.0	6.4	9.0	9.0	10.0
Apr. 20, 1927	20	24	25	18	18	21	2.8	3.4	4.0	3.8	5.0	5.0
Apr. 20, 1927	50	35	32	82	26	22	2.0	3.4	6.0	6.0	6.0	7.0
Apr. 22, 1927	15	14	11	13	10	7	2.8	5.8	8.0	12.0	12.0	14.0
Apr. 27, 1927	7 A. M.	26	26	26	28	27	19	0.8	4.2	7.0	8.0	7.0	7.6
Apr. 27, 1927	1 P. M.	66	34	30	30	28	24	1.4	3.4	5.0	5.0	8.6	6.4
Apr. 28, 1927	10 A. M.	200	51	39	36	33	32	0.40	0.8	1.4	1.4	4.0	2.0
Total.....	Jan. 3 to	2,577	1,660	1,436	1,331	1,138	1,115	76.30	123.95	164.90	229.75	282.25	248.40
Average.....	Apr. 28.	56	36	31	29	25	25	1.73	2.81	3.75	5.22	6.41	5.77

TABLE XXIX.—COMPLETE B. O. D. AND NO₃ DATA ON EXPERIMENTAL TRICKLING FILTER.

5/18/27 to 8/17/27.

Date	Hour	B. O. D.						Nitrate nitrogen					
		Infl.	2 ft.	4 ft.	6 ft.	8 ft.	10 ft.	Infl.	2 ft.	4 ft.	6 ft.	8 ft.	10 ft.
May 18, 1927	1 P. M.	75	42	34	30	27	18	0.4	4.0	8.0	8.4	10.0	10.0
May 25, 1927	7 A. M.	52	21	18	23	23	25	1.8	6.0	6.0	4.8	6.4	5.6
May 25, 1927	1 P. M.	90	36	30	26	21	15	2.0	5.0	7.0	8.0	8.0	12.0
June 1, 1927	7 A. M.	18	26	22	28	30	14	2.8	4.6	7.0	10.0	11.0	11.0
June 1, 1927	1 P. M.	154	70	52	36	32	30	2.0	4.0	6.0	7.0	9.0	9.0
June 8, 1927	7 A. M.							3.4	7.0	12.0	11.6	12.0	12.0
June 8, 1927	1 P. M.	156	58	51	41	34	32	2.0	4.0	7.0	8.0	9.0	9.0
June 10, 1927	10 A. M.	74	18	18	14	8	8	2.8	5.8	7.0	8.0	8.0	9.0
June 15, 1927	7 A. M.	36	26	19	18	18	14	2.0	3.8	6.0	6.0	7.0	6.0
June 15, 1927	1 P. M.	176	112	74	75	43	60	1.4	4.0	6.0	2.0	7.8	8.0
June 16, 1927	10 A. M.	118	44	36	30	11	19	1.4	3.8	5.8	7.0	8.0	9.0
June 22, 1927	7 A. M.	42	44	22	27	16	16	2.0	3.8	5.8	7.0	8.4	6.4
June 22, 1927	1 P. M.							2.0	4.0	7.0	5.8	6.0	7.0
June 28, 1927	10 A. M.							2.0	5.0	6.0	8.0	9.0	9.0
June 29, 1927	7 A. M.	22	12	6	5	7	4	1.4	3.4	3.8	4.0	3.4	5.0
June 29, 1927	1 P. M.	100	26	35	24	17	19	.8	5.0	6.0	9.0	12.	12.
July 5, 1927	10 A. M.	106	58	60	66	31	36	1.4	6.4	12.0	9.0	18.0	12.0
July 6, 1927	7 A. M.	14	6	6	7	7	4	2.8	4.0	6.0	7.0	7.0	6.0
July 6, 1927	1 P. M.	130	52	44	29	23	23	.8	4.0	3.8	6.0	10.0	9.0
July 11, 1927	10 A. M.	154	42	27	18	13	16	.8	5.0	12.0	12.0	12.0	16.0
July 13, 1927	7 A. M.	64	22	23	23	16	13	1.4	7.0	11.0	11.0	14.0	14.
July 13, 1927	1 P. M.	142	46	24	19	19	19	.8	3.8	4.0		9.0	9.0
July 20, 1927	7 A. M.	32	42	18	17	16	28	.8	3.8	5.0	5.8	5.0	12.0
July 20, 1927	1 P. M.	144	64	58	44	44	29	1.4	3.4	4.0			
July 27, 1927	7 A. M.							4.0	5.	11.0	8.0	12.0	9.0

DEPTH OF SEWAGE FILTERS

TABLE XXIX.—(Concluded).

Date	Hour	B. O. D.						Nitrate nitrogen					
		Inf.	2 ft.	4 ft.	6 ft.	8 ft.	10 ft.	Inf.	2 ft.	4 ft.	6 ft.	8 ft.	10 ft.
July 27, 1927	1 P. M.	148	48	68	41	53	56	1.4	3.8	5.0	9.0	7.0	7.8
Aug. 3, 1927	7 A. M.	88	22	34	45	26	25	.8	5.0	7.0	9.0	12.0	12.0
Aug. 3, 1927	1 P. M.	160	76	73	68	48	41	0.8	4.0	5.0	8.0	9.0	9.0
Aug. 4, 1927	10 A. M.	156	66	55	38	36	19	1.4	5.0	5.0	8.0	7.0	10.0
Aug. 16, 1927	10 A. M.	136	44	38	24	15	18	0.4	3.4	5.2	6.0	8.0	1.5
Aug. 17, 1927	7 A. M.	58	20	15	13	8	10	.6	2.4	3.6	3.6	3.8	3.8
Aug. 17, 1927	1 P. M.	156	56	45	27	19	22	.4	2.0	3.6	7.6	7.6	8.0
Total.....		2,801	1,199	1,005	842	661	633	50.2	141.2	209.6	224.6	276.4	279.1
Average.....		100	43	36	31	23	22	1.6	4.1	6.5	7.5	8.9	9.0
% removal.....			57%	64%	69%	77%	78%		35%	56%	65%	72%	73%

TABLE XXX.—COMPLETE B. O. D. AND NO. DATA ON EXPERIMENTAL TRICKLING FILTER.

8/22/28 to 11/2/27.

Date	Hour	B. O. D.						Nitrate nitrogen					
		Infl.	2 ft.	4 ft.	6 ft.	8 ft.	10 ft.	Infl.	2 ft.	4 ft.	6 ft.	8 ft.	10 ft.
Aug. 22, 1927	10 A. M.							.34	.34	6.0	8.0	8.0	9.
Aug. 24, 1927	7 A. M.							.76	2.8	3.6	6.8	6.4	6.4
Aug. 24, 1927	1 P. M.							.85	3.4	5.2	8.	8.	8.
Aug. 31, 1927	7 A. M.	79	81	63	54	50	58	.8	.8	1.4	2.0	1.4	1.4
Aug. 31, 1927	1 P. M.	198	94	146	68	50	82	2.	7.0	10.	9.0	10.	10.
Sept. 7, 1927	7 A. M.	Filter unloading,	possibly	due to rain.			Samples not run.						
Sept. 9, 1927	10 A. M.	190	125	60	54	46	52	2.0	4.8	12.0	5.8	5.0	6.0
Sept. 14, 1927	7 A. M.	100	54	42	56	18	24	.8	3.8	5.8	8.0	7.0	8.0
Sept. 14, 1927	1 P. M.							.8	1.4	6.0	9.0	12.	12.0
Sept. 21, 1927	7 A. M.	100	190	220	240	210	130	2.8	16.	16.	20.	18.	24.
Sept. 21, 1927	1 P. M.	280	220	165	95	95	95	1.4	6.4	9.0	12.0	14.0	24.0
Sept. 27, 1927	10 A. M.	210	240	175	250	225	235	1.4	12.	12.	16.	16.	18.
Sept. 28, 1927	7 A. M.	225	195	18	34	30	18	4.4	7.0	7.6	12.0	14.	14.0
Sept. 28, 1927	1 P. M.	105	45	35	40	30	20	3.0	5.8	7.0	10.0	12.0	12.0
Oct. 5, 1927	7 A. M.	22	32	24	20	22	18	3.0	4.	8.	9.0	14.	14.
Oct. 5, 1927	1 P. M.	116	42	42	28	24	18	1.4	5.0	5.0	6.0	8.0	8.4
Oct. 12, 1927	10 A. M.	36	20	18	12	58	8	2.4	4.	4.4	5.0	7.0	7.0
Oct. 19, 1927	7 A. M.	23	5	3	13	2	1	3.4	4.	6.4	8.4	9.0	10.0
Oct. 19, 1927	1 P. M.	198	66	52	40	26	16	5.0	4.4	6.0	7.0	10.0	9.0
Oct. 21, 1927	10 A. M.	120	37	30	14	10	6	2.8	4.	5.0	8.2	9.0	12.0
Oct. 26, 1927	7 A. M.	24	20	17	11	12	6	2.	7.	7.6	12.0	12.	12.0
Oct. 26, 1927	1 P. M.	208	80	60	36	23	27	2.	4.6	4.4	12.0	12.	12.

DEPTH OF SEWAGE FILTERS

PART III

TRICKLING FILTER DOSING

BY G. C. HABERMEYER AND H. L. WHITE

Considerable trouble is experienced in dosing small experimental trickling filters at definite rates and in securing even fairly uniform discharge over the filter area. With a smaller area than served by one nozzle in a large plant it is desirable to reduce the rate of flow through a nozzle, and this adds to other troubles encountered.

In planning our dosing apparatus, an effort was made to secure uniform distribution with a simple apparatus that could be used for different rates and different periods of dosing and resting without much change in the apparatus. After some trials a satisfactory apparatus was devised, a sketch of which is shown in Fig. 19.

Sewage is pumped into a half barrel placed several feet above the surface of the filter. From this half barrel a short pipe carries sewage to a dosing tank, the top of which is about level with the bottom of the barrel. An overflow pipe is connected through the

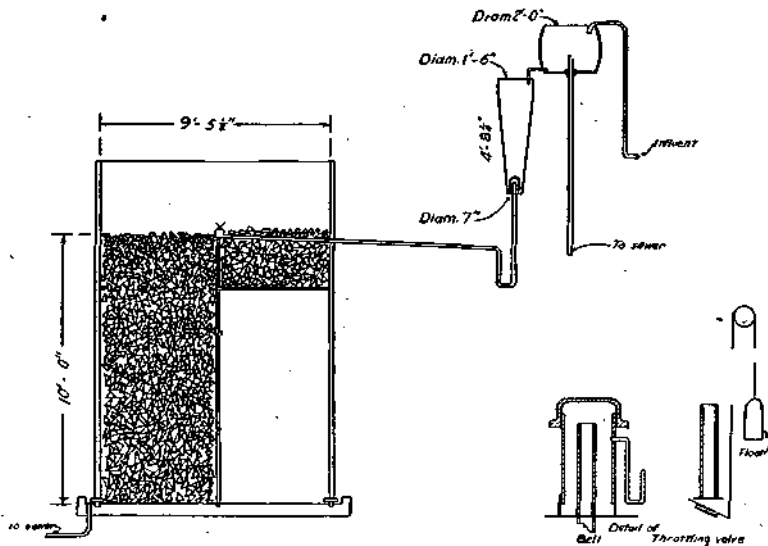

Section

FIG. 19.

bottom of the half barrel. By changing nipples on the top of the overflow pipe, the sewage level can be held at any desired elevation, so as to give any desired rate of flow into the dosing tank. It was necessary to clean the short pipe from the half barrel with a test tube brush, daily.

Sewage flows from the dosing tank to the filter through a siphon, a vertical pipe, a trap, and a pipe with a slight slope upward to the nozzle. Siphons and traps of small pipe, with siphon auxiliaries, were tried and discarded. A bell consisting of a 4-inch pipe cap is now used on the siphon.

One auxiliary that was tried with the pipe siphons and also with the bell was a trap of quarter-inch pipe attached to the top of the siphon. This trap was nearly as deep as the main trap and was filled by the sewage flowing into the dosing tank. It was expected that this would give sharp start and stop to the siphon and greatly reduce the quantity of air discharged through the main trap to the filter and thus give more uniform discharge. Results secured with this very small auxiliary were not satisfactory, and it was discarded.

The auxiliary now used consists of a trap of quarter-inch pipe screwed into the side of the bell of the siphon. A detail of the trap and bell is shown in Fig. 19. When the sewage level goes below the top of the outlet pipe while the tank is discharging, sewage is siphoned under the bell until enough air is drawn in to break the siphon. The auxiliary trap is placed at such an elevation that the sewage is drawn from it by the suction created by the siphon, just before air is drawn below the bottom of the bell. The siphon breaks sharply, since the quarter-inch pipe admits air into the bell after the bottom of the bell has been covered by incoming sewage. When the auxiliary trap is not used, the bottom of the bell is covered—by the sewage coming in and the sewage falling from inside the bell—before the bell is completely filled with air, and the siphon does not break sharply.

In order that, with the dosing tank nearly empty, sewage could be sprayed onto the central part of the filter at a rate less than the average rate of inflow into the dosing tank, a throttling valve was placed against the end of the inlet pipe into the dosing tank. The valve was operated by a float in the dosing tank as shown in Fig. 19. A wire from the float passed up over a pulley and then down to

the valve. As the sewage level lowered when the tank was dosing, the float gradually closed the valve. This reduced the rate of inflow sufficiently to permit the siphon under the bell to break. The valve seat was made uneven purposely, so that a small stream of sewage flowed from the pipe even when the valve was closed. This allowed sewage to flow into the tank when the dosing period was over, thus raising the sewage level sufficiently to open the valve and fill the tank again. This throttling device was discarded because clogging prevented uniform operation, because it was difficult to determine the amount of sewage applied to the filter, because the long time the valve was held nearly closed gave a long time between doses to the filter, and because it was found that the lowest rate of flow from the dosing tank through the nozzle was greater than the average rate of inflow, so that throttling the inflow was not necessary.

A dosing tank was then designed after some preliminary experiments with a barrel. In the preliminary experiments the relation between the elevation of the water level in the barrel above the nozzle, or the head on the nozzle, the rate of discharge, and the distance from the nozzle to the area that was being sprayed, were obtained. Nozzles used in the first tests discharged at a higher rate than desired. The capacity of a Worcester nozzle was then reduced by fastening over the orifice a brass disc with a small circular opening. The nozzle clogged on the first discharge but seldom clogged thereafter. With a nozzle chosen, the proper elevation of the top of a dosing tank to spray to the outer edge of the filter, the elevation of the bottom of the tank to spray close to the center of the filter, and the shape of the tank, were determined. For convenience in making these determinations, radii of the filter were divided into fourths and marked with nails. Water levels in the dosing tank were marked when the spray was to the outer edge of the filter, to three-fourths the radius, to half the radius, and to one-quarter the radius. The relative filter areas between the points marked on the radii were seven, five, three, and one; and, with due allowance for the constant inflow to the dosing tank, this gave the proper relative capacity of the parts of the dosing tank between the marked points. The relative areas, expressed in percentage of the total, were 44, 31, 19, and 6; and the percentage of the total sewage applied to these areas, with the tank designed and with all connecting pipe clean, during two tests, averaged 55, 36, 9, and 0, respectively. The outer 75 per cent of the area was dosed higher than the average. Much

of the remainder of the spray fell at a little less than half the radius from the center, giving about 10 per cent of the area sprayed at about normal rate.

As the pipe became dirty, the spray fell a little nearer the center, and average conditions were better than during any one test. It was considered advisable to have little sewage fall on the inner 6 per cent of the area, as it would fall on or close to partition walls in the filter and flow down the walls.

The sprinkling filter was started on November 30, 1926. Its area was .0016 acres. During the first month of operation the rate was slightly low, and stops were more frequent than later, giving a net rate of 1,800,000 gallons per acre per day. This was increased the next month (January) to 1,900,000 gallons per acre per day; and from that time until September 15, 1927, excepting for a shut down of about 67 hours due to flooding the experiment station by an adjacent stream, the quantity filtered gave a net rate of practically 2,000,000 gallons per acre per day.

PART IV

BIOLOGICAL DATA ON THE SPRINKLING FILTER

BY S. L. NEAVE WITH A. M. BUSWELL

An investigation was made of the numbers and kinds both of bacteria and of higher organisms occurring at different depths in the filter bed. Samples were collected at the city treatment plant at intervals of approximately six days, from March 2 to September 2 (1925) inclusive, for bacterial counts, and from March 2 to May 21 (1925) inclusive, for microscopic enumeration of the higher forms; the influent sample was collected from the spray nozzle, and portions of effluent at different depths from the sampling pipes (page 91), and an effluent sample from the underdrains. This method of sampling assumes that sediment found in the sample from a given level is indicative of the film composition at that level plus the levels above it.

Bacterial counts were made in terms of physiological groups (ammonifiers, protein digesters, etc.) by planting decimal dilutions of the sample in suitable media, as recommended by Hotchkiss (New Jersey Agr. Expt. Sta., Bulletin 390, 1923). The microscopic enumerations were made by the usual Sedgwick-Eafter method after a concentration of the sample of 5:1 by centrifuging; the results given are the number of individuals, or, in the case of filamentous forms, zoogloea and debris, the area in "standard units" (20 microns square) occupied, per cubic centimeter of original sample.

During the six months period of observation a total of 22 sets of samples were examined, and the average results are summarized in Table XXXI. No seasonal fluctuations in the counts were observed, with the exception that larger numbers of bacteria producing ammonia from peptone occurred during the warm June—September period than during the cool March—June season.

Interpretation of these data is subject to two restrictions: first, the finding by culture methods of a given physiological group does not necessarily mean active organisms of that group in the sample—they may have been present as spores awaiting a suitable environment

for germination; and, second, the groups are not mutually exclusive, especially as regards the proteolytic forms.

In general, however, the lytic forms associated with anaerobic activity are reduced in numbers in passing through the filter bed, while the synthetic or oxidizing flora shows an increase in the body of the bed. The rapid temporary rise in protein digesters in the upper levels may be attributed to the abundant food-supply in the film and the destruction by oxidation of inhibitory metabolic products, though more probably these proteolytic species are normal inhabitants of the surface film and are maintained by the colloidal nitrogenous components of the tank effluent, since marked clarification is observed even at the two-foot level. Similar counts were obtained at the New Jersey Station (Hotchkiss, loc. cit.).

Attention is called at this point to the secondary increase in lytic forms below the six-foot level, accompanied by slight increases in sulfate reducers, cellulose fermenters and denitrifiers; later, evidence will be presented of a retention of sloughed-off film in the lower levels of the bed, and these bacterial counts substantiate the other evidence for this retention.

TABLE XXXI.—PHYSIOLOGICAL GROUPS OF BACTERIA FOUND IN THE SPRINKLING FILTER SAMPLES.

Average counts, in thousands per c. c. for the period March 2 to September 2, inclusive.

Physiological groups	Infl.	2' level	4' level	6' level	8' level	Eff.
Ammonia from Peptone.....	610	1490	1850	496	955	1320
Proteolysis of Gelatine.....	51	33	25	20	15	12
Proteolysis of Coag. Egg Albumen.....	1490	1660	600	910	1300	1200
H ₂ S from Peptone.....	820	200	150	34	29	34
H ₂ S from Sulfates.....	5.4	1.8	1.3	0.8	1.2	0.3
Sulfate from Thiosulfate.....	5.0	1.2	1.5	7.1	12.8	12.8
Cellulose Fermentation (aerobic)*.....	1.3	0.4	0.9	0.9	1.3	0.4
Nitrites from Ammonia.....	0.1	0.7	0.4	1.4	0.4	0.5
Nitrates from Nitrites**.....						
Denitrification.....	210	370	210	140	240	120

* Aerobic and anaerobic cellulose media were initially used, but the counts agreed so closely that the latter were discontinued early in the investigation.

**The nitration group is omitted because difficulty was encountered in the chemical tests applied after incubation; only a few of the nitrate determinations were considered trustworthy, and these can not justifiably be averaged to represent the period.

TABLE XXXII.—LARGER ORGANISMS FOUND IN SPRINKLING FILTER SAMPLES.

Average counts in individuals per c. c. for the period March 2 to May 21.

Type of organism	Infl.	2' level	4' level	6' level	8' level	Eff.
Sarcodina.....	9	1110	1705	2030	1990	2010
Flagellates.....	2350	4540	3780	2790	2050	1640
Infusoria:						
Holo-trichs Hetero-						
trichs.....	370	730	1140	1050	1270	890
Hypotrichs.....		85	79	94	94	19
Peritrichs.....	18	126	98	85	225	19
Suctorina.....		42	25	8	8	
Average total.....	390	940	1320	1230	1590	930
Rotifers.....		1	43	73	49	69
Nematodes.....		29	78	86	78	63
Spirilla.....	1500	680	180			
Zoogloea, bacterial fila- ments and org. debris*	64,400	133,200	232,300	229,500	133,800	128,400

* Values are standard units per c. c.

During the two and one-half months sampling period, 12 sets of samples were examined. Differential counts by genera were made, but the latter have been combined and averaged, as shown in Table XXXII.

Detailed tabulations of the generic counts gave no conclusions bearing upon the present topic and they are, therefore, omitted. In only a few cases were the species determined, and generic groupings are too broad for an ecological discussion of the data. In a general way, however, the change from pollution-tolerant (polysaprobic) to mesosaprobic and even oligosaprobic forms may be noted on passing from influent to effluent.

The forms included in the differential counts are listed in Table XXXIII, together with notes on their depth and seasonal maxima.

This series of samples did not include the spring or fall unloading; however, two counts have been made (1927) on the filters at the experimental plant during times of heavy sloughing-off. These results (Table XXXIV), as well as those for the city treatment plant, show an interesting relation between film debris and the depth from which the sample is collected. Instead of each succeeding level showing an increased proportion of debris, the amount actually becomes less below the six-foot level. This observation suggests that

the lower levels of the bed act as a strainer and retain a portion of the material sloughed off at higher levels, and the changes in bacterial flora, already mentioned, not only confirm this view, but also indicate a reversion to the lytic, rather than purely oxidative, type of biological processes. Eeference to Table X (pp. 44-45), shows that further confirmation of this retention of solids is afforded by the values for settleable solids obtained in the chemical analysis.

This point has a practical bearing on filter-plant design, for if no secondary settling tank is to be installed a deeper filter insures a greater freedom from effluent suspended solids with the sacrifice of only a small part of the nitrate content. On the other hand, with a secondary settling tank, both construction-cost and chemical data favor a filter only six feet deep.

TABLE XXXIII.—THE GROUPS AND DISTRIBUTION OF ORGANISMS COUNTED IN THE FILTER BED SAMPLES.

SARCODINA		Seasonal maximum March 20-28.
Amoeba		Occasionally in influent; abundant in lower half of bed in March.
Arcella	}	In lower half of bed; abundant in April.
Trinema		
Diffugia		
Euglypha		
Heliozoa		Occasionally in lower part of bed (April and May).
MASTIGOPHORA		Seasonal maximum March 20-25.
Small flagellates		Distinct maximum at 2' to 4' level, then decline; most abundant in March.
Astasia		Occasionally in lower half of bed (April).
Euglena	}	Occasionally in upper half of bed (April).
Notosolenus		
Peranema		
Synura		A few throughout the bed (March and April).
INFUSORIA		No definite seasonal maximum.
Holotrichs:		
Holophyra		Lower half of bed (April).
Spathidium		Effluent (March).
Microthorax		Lower half of bed (April).
Lionotus	}	Lower half of bed (March and April).
Lionopsis		
Loxophyllum	}	Throughout bed (March and April).
Paramoecium		
Nassula		Upper part of bed (April).

TABLE XXXIII—(Concluded).

Colpoda	}	Influent and upper part of bed (March).
Colpidium		
Enchelys	}	Occasionally observed.
Prorodon		
Loxodes		
Amphileptus		
Chilodon		
Glaucoma		
Heterotrichs:		
Metopus		Occasionally observed.
Spirostomum		Lower half of bed (March and April).
Hypotrichs:		
Oxytricha	}	Lower part of bed (March to May).
Euplotes		
Aspidisca	}	Occasionally observed.
Uroleptus		
Peritrichs:		
Vorticella	}	Throughout bed (March to May).
Opercularia		
Carchesium		Occasionally observed.
Suctoria:		
Acineta		Lower part of bed (March to May).
MISCELLANEOUS		
Rotifers		Lower half of bed; rapid increase in April.
Nematodes		Few throughout bed; maximum April 16-28.
Diatoms		Appeared throughout bed (April 22); increasing to end of run.
Psychoda larvae		Appeared April 22.
Zoogloea ramigera		Upper half of bed, especially in March and April.
Filamentous bacteria (except Beggiatoa)		Maximum in influent, declining throughout bed; seasonal maximum in April.
Beggiatoa		Maximum in middle of bed in April and May.
Organic debris		Maximum at 4' to 6' level; small seasonal maximum March 20-29 and a large one April 16-28.

TABLE XXXIV.—MICROSCOPIC COUNTS ON EXPERIMENTAL FILTER DURING UNLOADING.

(Individuals per c. c.)

September 21, 1928.

Organisms	Infl.	2-ft. effl.	4-ft. effl.	6-ft. effl.	8-ft. effl.	10-ft. effl.
Rhizopods:						
Amoeba proteus.....	40	40	80	160	80	160
Amoeba limax.....	0	0	20	0	0	60
Amoeba guttula.....	0	0	0	40	0	0
Euglypha sp.....	20	1880	2060	1200	420	1380
Arcella sp.....	20	160	340	80	120	220
Flagellates:						
Small flagellates.....	440	1160	1040	3280	3280	1400
Peranema sp.....	0	0	0	0	0	0
Euglena sp.....	0	0	0	20	0	0
Ciliates:						
Holotrichs.....	20	100	140	120	140	300
Heterotrichs.....	20	80	60	120	100	100
Peritrichs.....	0	280	220	340	260	300
Hypotrichs.....	0	20	60	40	40	60
Suctorina.....	0	40	40	0	20	0
Cysts.....	40	340	100	140	160	140
Bacteria:						
Rod forms.....	24800	12800	8400	9000	10600	4800
Spirilla.....	1420	0	0	0	0	0
Filaments, zoogloea and organic debris*	8900	10500	12300	5300	5800	4100
Mold hyphae.....	60	140	60	20	0	60
Mold spores.....	0	0	0	0	0	0
Nematodes.....	0	180	100	140	140	180
Rotifers.....	0	200	60	200	40	60
Rhizopods:						
Amoeba proteus.....	0	20	20	40	40	60
Amoeba limax.....	0	0	0	0	20	20
Amoeba guttula.....	0	0	20	460	280	460
Euglypha sp.....	0	2400	2560	1360	440	1520
Arcella sp.....	0	60	80	20	20	200
Flagellates:						
Small flagellates.....	240	380	1100	1000	820	780
Peranema sp.....	0	0	60	20	40	20
Ciliates:						
Holotrichs.....	40	60	80	50	500	540
Heterotrichs.....	0	20	20	20	60	20
Peritrichs.....	20	640	720	500	480	640
Hypotrichs.....	0	40	100	120	240	100
Suctorina.....	0	0	0	60	100	100
Cysts.....	60	1180	1240	1480	1780	1560
Bacteria:						
Rod forms.....	16200	11200	9000	7600	7600	7400
Spirilla.....	700	360	40	0	0	0
Filaments, zoogloea and organic debris*	3870	8050	4590	11300	9900	8800
Mold hyphae.....	20	60	40	160	80	20
Mold spores.....	40	0	0	0	0	0
Nematodes.....	0	120	60	160	200	80
Rotifers.....	0	120	120	80	40	20

* Standard units per c. c.